



## Return-Suction Filters

### E 598 • E 998

- Tank top mounting
- Connection up to G1½ and SAE 2½
- Nominal flow rate up to 850 l/min

# Description

## Application

For operation in units with hydrostatic drives, when the return flow is under all operating conditions higher than the oil flow of the boost pump.

## Performance features

Protection against wear:

By means of filter elements that, in full-flow filtration, meet even the highest demands regarding cleanliness classes.

Suction filter function:  
flow,  
Return filter function:

Because of the 100 %-filtration of the suction no dirt can get into the boost pump.

By means of full-flow filtration in the system return, the pumps above all are protected from dirt particles remaining in the system after assembly, repairs, or which are generated by wear or enter the system from outside.

## Functional characteristics

The hydraulic oil returning from the circuit (A) passes the filter element (1), is pressurized by a 0,5 bar check valve (2) and supplied to the boost pump (B). The surplus oil flows filtered over the integral check valve into the reservoir.

As the boost pump is always fed with pressurized oil, the risk of cavitation is minimized and full performance is available even during the critical cold start phase.

Six integral pressure relief valves (3) prevent too high back pressure and protects the shaft seals against damages. As this valves lead the oil directly into the tank there is no direct connection between the return line (A) and the connection of the boost pump (B) (no bypass valve function).

Function (schematic):

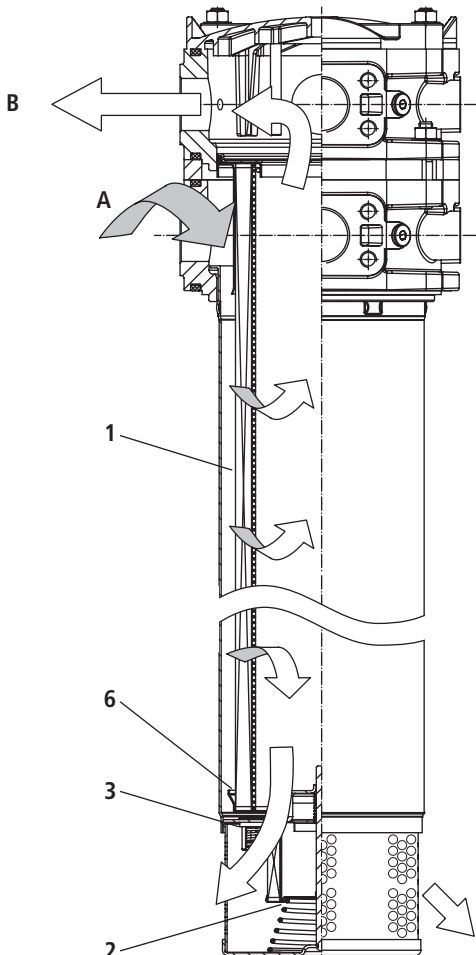

The emergency-suction valve (4) with 200 µm protection strainer (5) supplies the boost pump in case of a short term of lack of oil. During normal operation, a lack of oil may definitely not occur (refer to „Design“ section).

Emergency-suction (schematic):

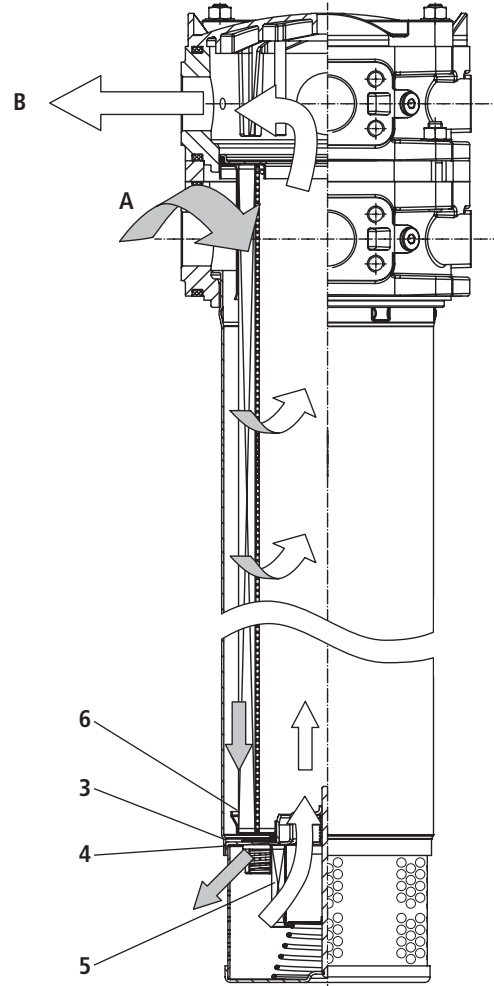

## Start up / Deaeration

At first start up or at start up after repair, deaerating instructions published by the manufacturers of hydraulic drives must be observed.

## Filter maintenance

By using a clogging indicator the correct moment for maintenance is indicated and guarantees therefore the optimum utilization of the filter elements.

## Filter elements

Flow direction from outside to the centre. The star-shaped pleating of the filter material results in:

- large filter surfaces
- low pressure drop
- high dirt-holding capacities
- long service life

The dirt collection bowl (6) prevents dirt particles accumulated at the filter element from entering into the tank during maintenance.

## Accessories

Electrical and optical clogging indicators are available. Dimensions and technical data see catalogue sheet 60.20.

# Layout

## General

In machines with a hydrostatic drive and combined working hydraulic system, return-suction filters replace the suction or pressure filters previously required for the feed pump of the closed-loop hydrostatic drive circuit as well as the return filter for the open-loop working hydraulic circuit. While each circuit operates independently with separate filters, the combination of the two circuits via the return-suction filter causes interaction between the circuits. If the design criteria described below are taken into account, you can take full advantage of the benefits provided by the return-suction filter concept, thus making sure that your system performs reliably even under extreme operating conditions.

## Required return flow in the system

In order to maintain a precharging pressure of approx. 0,5 bar at the intake of the feed pump, the return flow must exceed the suction flow under any operating conditions:

- Versions with hole ( $\varnothing$  8 mm) in the pressurizing valve: at least 30 l/min of excess flow

## Permitted feed pump flow rate

- at operating temperature ( $v < 60 \text{ mm}^2/\text{s}$ ,  $\text{rpm} = \text{max}$ ): feed pump flow rate  $< 0,5 \times$  rated return flow according to column 2 of selection table
- at cold start-up ( $v < 1.000 \text{ mm}^2/\text{s}$ ,  $\text{rpm} = 1.000 \text{ min}^{-1}$ ): feed pump flow rate  $< 0,2 \times$  rated return flow according to column 2 of selection table

Please contact us if your system operates with higher flow rates than stated above.

## Flow velocity in the connecting lines

- Flow velocity in the return lines  $\leq 4,5 \text{ m/s}$
- Flow velocity in the suction lines  $\leq 1,5 \text{ m/s}$

## Permitted pressure in the suction lines

At cold start up ( $v < 1.000 \text{ mm}^2/\text{s}$ ,  $\text{rpm} = 1.000 \text{ min}^{-1}$ ): feed pump flow rate  $\leq 0,2 \times$  rated return flow. The pressure loss in the suction lines must not exceed 0,4 bar.

## Backpressures in system return lines

If drain oil from the hydrostatic drive is routed across the filter in addition to the flow of the open-loop circuit, the following has to be observed in order to protect the shaft seals:

- permitted leakage oil pressure for a given viscosity and speed (manufacturer's specifications!)
- pressure loss caused by the leakage oil pipes
- pressure loss caused by the oil cooler used
- backpressure of the filter for a given flow rate or kinematic viscosity (refer to pressure loss diagrams)

Depending on the application, the use of a cooler bypass valve is recommended.

Generously sized drain oil pipes are also of advantage.

## Filter fineness grades

With the filter fineness grades available, the following oil cleanliness according to ISO 4406 can be achieved:

- 10EX2: 18/15/11 ... 14/11/7
- 16EX2: 20/17/12 ... 17/14/10

Even with the 16EX2 filter fineness grade, the requirements specified by manufacturers of hydrostatic drives are sometimes exceeded significantly. If components requiring a still better oil purity are used, we recommend the 10EX2 filter fineness grade.

## Suggested circuit layouts

A) The leakage oil of the hydrostatic drive is routed across the filter.

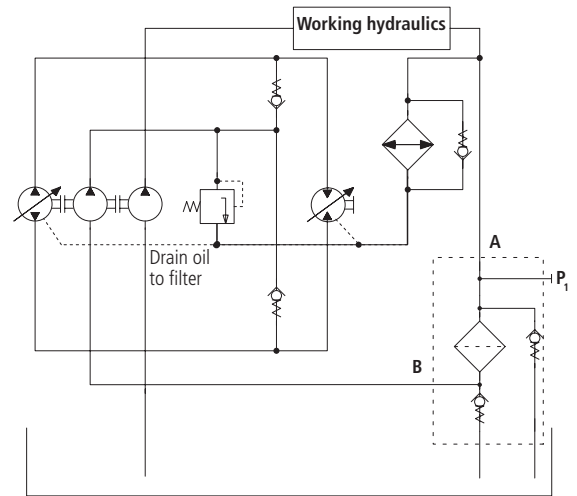

The entire dirt produced in the hydrostatic drive by abrasion is filtered out immediately and is thus not taken in by the pump of the open-loop circuit. This circuit layout is always recommended if the return flow only slightly exceeds the suction flow, i.e. if there is a risk that the 0,5 bar precharging pressure cannot be maintained.

B) The drain oil of the hydrostatic drive is not routed across the filter but is discharged directly into the tank.

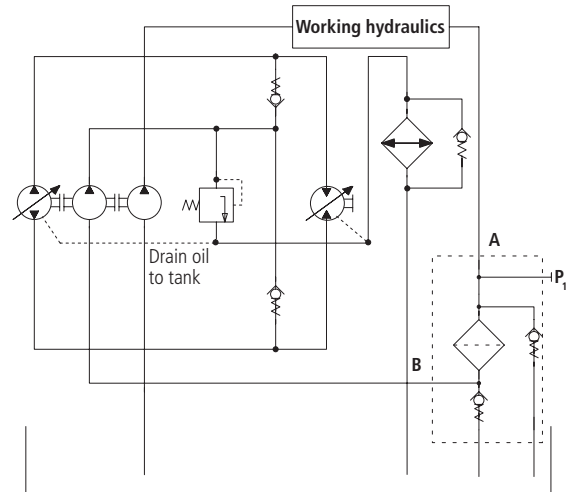

This circuit layout has the advantage that drain oil pressures are comparatively low.

# Characteristics

## Nominal flow rate

Up to 850 l/min in return line (see Selection Chart, column 2)

Up to 425 l/min feed pump flow rate (see Layout)

The nominal flow rates indicated by ARGO-HYTOS are based on the following features:

- closed by-pass valve at  $v \leq 200 \text{ mm}^2/\text{s}$
- element service life > 1.000 operating hours at an average fluid contamination of 0,07 g per l/min flow volume
- flow velocity in the return lines  $\leq 4,5 \text{ m/s}$
- flow velocity in the suction lines  $\leq 1,5 \text{ m/s}$

## Connection

Threaded ports according to ISO 228 or DIN 13 and SAE flange (3.000 psi).

Sizes see Selection Chart, column 6 (other port threads on request).

Please consider the connection size regarding max. flow volumes.

## Filter fineness

10  $\mu\text{m(c)}$  ... 16  $\mu\text{m(c)}$

$\beta$ -values according to ISO 16889

(see Selection Chart, column 4 and diagram Dx)

## Dirt-holding capacity

Values in g test dust ISO MTD according to ISO 16889

(see Selection Chart, column 5)

## Hydraulic fluids

Mineral oil and biodegradable fluids

(HEES and HETG, see info sheet 00.20).

## Temperature range

-30 °C ... +100 °C (temporary -40 °C ... +120 °C)

## Viscosity at nominal flow rate

- at operating temperature:  $v < 60 \text{ mm}^2/\text{s}$
- as starting viscosity:  $v_{\text{max}} = 1.200 \text{ mm}^2/\text{s}$
- at initial operation: The recommended starting viscosity can be read from the diagram D (pressure drop as a function of the kinematic viscosity) as follows: Find the 70 %  $\Delta p$  of the cracking pressure of the by-pass valve on the vertical axis. Draw a horizontal line so that it intersects the  $\Delta p$  curve at a point. Read this point on the horizontal axis for the viscosity.

## Operating pressure

Max. 10 bar

## Materials

Screw-on cap: Aluminium alloy

Filter head: Aluminium alloy

Filter bowl: Steel

Seals: NBR (FPM on request)

Filter media: EXAPOR®MAX 2 – inorganic multi-layer microfibre web

## Fitting position

Up to 15° from the vertical, preferably vertical

Even under unfavourable operating conditions (min. oil level, max. sloping) the oil outlet resp. emergency suction has to be below the oil level.

## Diagrams

### $\Delta p$ -curves for complete filters in Selection Chart, column 3

(50 % of the nominal flow volume via connection B)

**D1** Pressure drop as a function of the **flow volume**  
at  $v = 35 \text{ mm}^2/\text{s}$  (0 = casing empty)

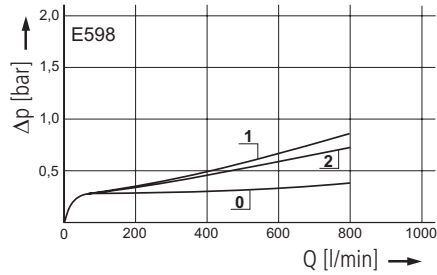

Pressure drop as a function of the **kinematic viscosity**  
at nominal flow

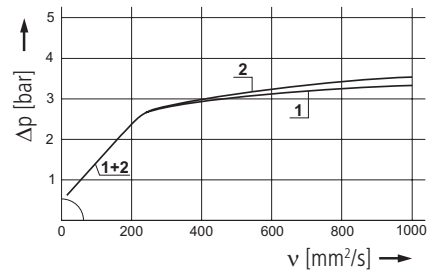

**D2** Pressure drop as a function of the **flow volume**  
at  $v = 35 \text{ mm}^2/\text{s}$  (0 = casing empty)

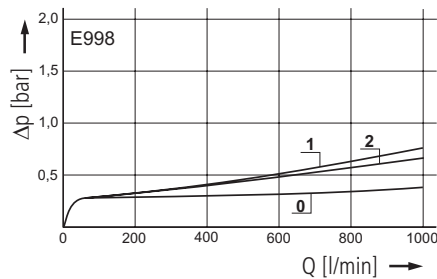

Pressure drop as a function of the **kinematic viscosity**  
at nominal flow

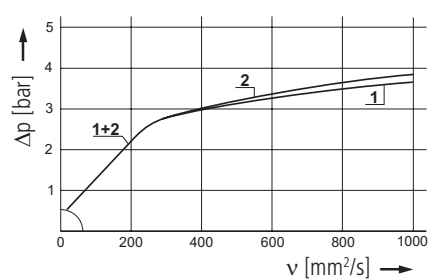

### Filter fineness curves in Selection Chart, column 4

**Dx** Filtration ratio  $\beta$  as a function of particle size  $x$  obtained by the  
Multi-Pass-Test according to ISO 16889

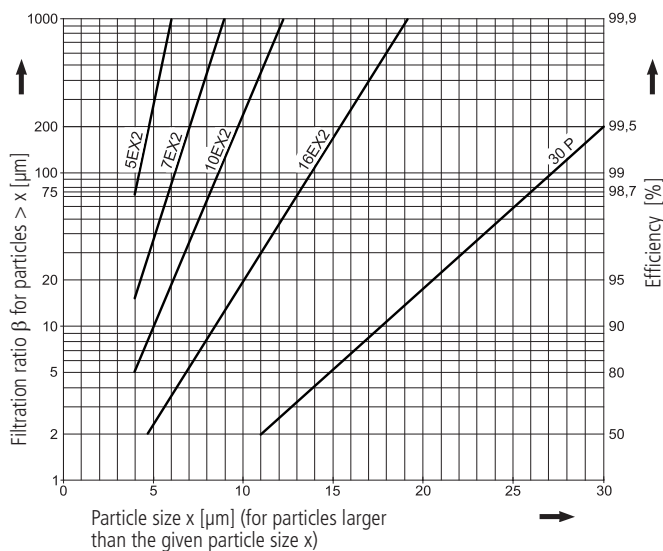

The abbreviations represent the following  $\beta$ -values resp. finenesses:

**For EXAPOR®MAX 2 and Paper elements:**

**5EX2** =  $\beta_{5(c)} = 200$  EXAPOR®MAX 2

**7EX2** =  $\beta_{7(c)} = 200$  EXAPOR®MAX 2

**10EX2** =  $\beta_{10(c)} = 200$  EXAPOR®MAX 2

**16EX2** =  $\beta_{16(c)} = 200$  EXAPOR®MAX 2

**30P** =  $\beta_{30(c)} = 200$  Paper

Based on the structure of the filter media of the 30P paper elements, deviations from the printed curves are quite propable.

For special applications, finenesses differing from these curves are also available by using special composed filter material.

# Selection Chart

Part No.	Nominal return flow rate <sup>1</sup>	Pressure drop see diagram <b>D</b> /curve no.	Filter fineness see Diagr. <b>Dx</b>	Dirt-holding capacity	Connections A/B SAE (3000 psi)	Cracking pressure of CV <sup>2</sup>	Cracking pressure of PRV <sup>3</sup>	Symbol	Suction valve	Replacement filter element Part No.	Weight	Remarks		
1	l/min	2	3	4	g	5	6	7	8	9	10	11	12	13
E 598-256	470	<b>D1/1</b>	10EX2	170	2 + 5 connections	0,5	2,5	1	•	V7.1440-06	11,5	4 + 5		
E 598-257	630	<b>D1/2</b>	16EX2	180	2 + 5 connections	0,5	2,5	1	•	V7.1440-07	11,5	4 + 5		
E 998-256	680	<b>D2/1</b>	10EX2	270	2 + 5 connections	0,5	2,5	1	•	V7.1460-06	13,8	4 + 5		
E 998-257	850	<b>D2/2</b>	16EX2	280	2 + 5 connections	0,5	2,5	1	•	V7.1460-07	13,8	4 + 5		

All filters are delivered with plugged clogging indicator connections M12 x 1,5.  
 As clogging indicators on the return side (P<sub>1</sub>) either manometers or electrical pressure switches can be used.  
 The monitoring of the vacuum on the suction side (P<sub>2</sub>) is additionally possible.

**Order example: The filter E 598-256 has to be supplied with 5 + 5 connections (A<sub>1</sub> ... A<sub>5</sub>, B<sub>1</sub> ... B<sub>5</sub> ).**

**Order description:**

**E 598-556**

**Connections:**

2 various options are available:

Option	A <sub>1</sub>	A <sub>2</sub>	A <sub>3</sub>	A <sub>4</sub>	A <sub>5</sub>	B <sub>1</sub>	B <sub>2</sub>	B <sub>3</sub>	B <sub>4</sub>	B <sub>5</sub>	
2 + 5 connections	SAE 2 1/2	G1 <sup>6</sup>	-	-	-	G1 1/4 / SAE 1 1/2	G1	G3/4	G1 1/2 / SAE 2		2
5 + 5 connections	G1 1/4 / SAE 1 1/2	G1	G3/4	G1 1/2 / SAE 2	G1 1/4 / SAE 1 1/2	G1	G3/4	G1 1/2 / SAE 2			5

**For the appropriate clogging indicator see catalogue sheet 60.20.**

**Remarks:**

- The start of the red area of the manometer respectively the switching pressure of the electrical pressure switch has always to be lower than the cracking pressure of the pressure relief valve (see Selection Chart, column 8).
- Clogging indicators are optional and always delivered detached from the filter.
- The filters listed in this chart are standard filters. If modifications are required, we kindly ask for your request.
- For deaeration a bleed valve (for connection P<sub>1</sub>) with Part No. SV 0112.15 is available.

<sup>1</sup> The individual flow rates must be matched to the connections      <sup>3</sup> Cracking pressure of pressure relief valves      <sup>5</sup> with emergency-suction valve and protection strainer (200 µm)  
<sup>2</sup> Cracking pressure of check valve      <sup>4</sup> with hole Ø 8 mm in the check valve for oil drain when opening the filter cover      <sup>6</sup> Connection G1 (A<sub>2</sub>) with locking screw



## Dimensions

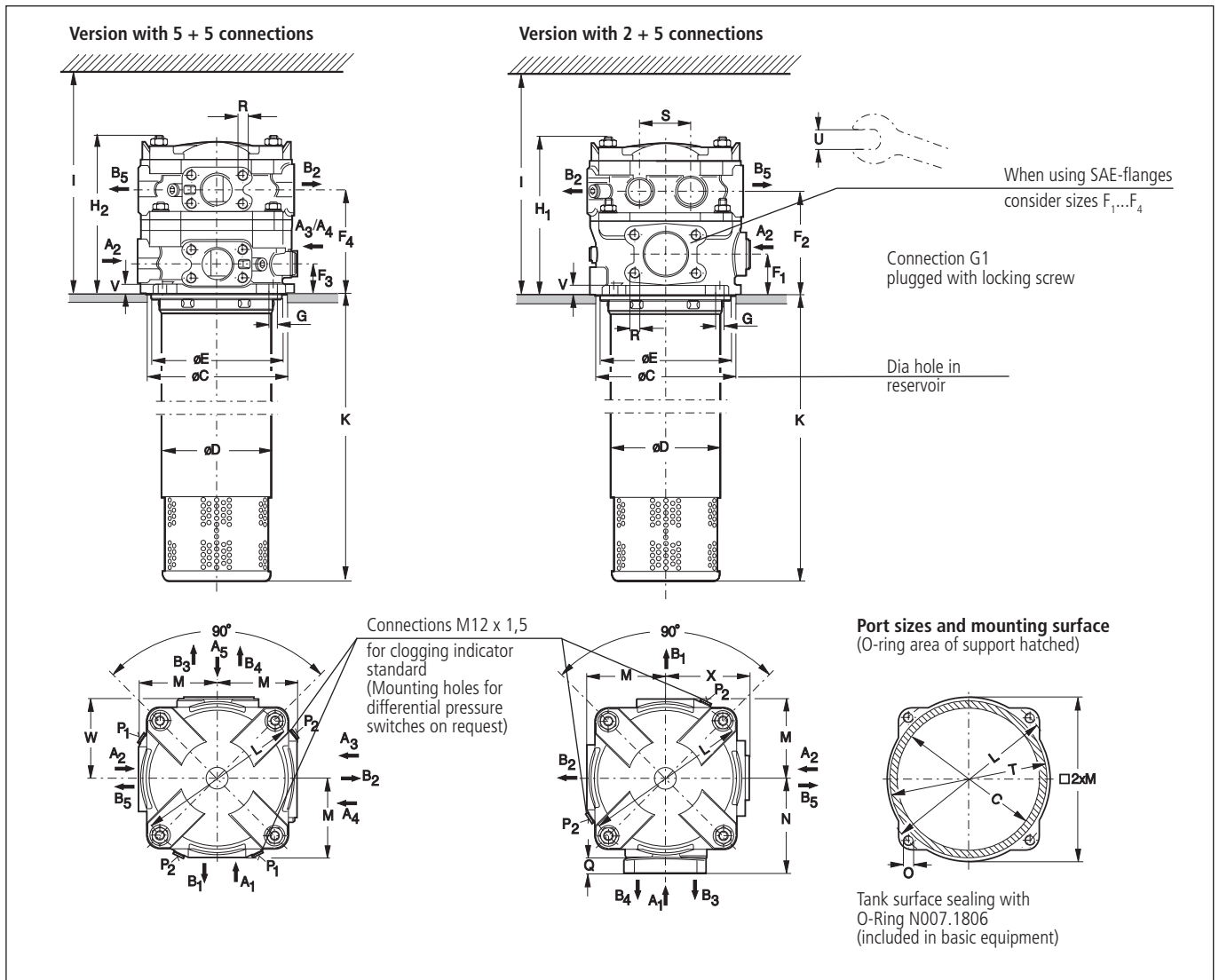

## Measurements

Type	A	B	C	D	E	$F_1^*$	$F_2^*$	$F_3^*$	$F_4^*$	G	$H_1$	$H_2$	I
E 598	s. Selection	s. Selection	180	152	179	55	141,5	41,5	139,5	11,5	216	214	660
E 998	Chart	Chart	180	152	179	55	141,5	41,5	139,5	11,5	216	214	860
Type	K	L	M	N	O	Q	R	S	T	U	V	W	X
E 598	406	220	106	125	M10	20	M12	70	200	17	12	104	115
E 998	612	220	106	125	M10	20	M12	70	200	17	12	104	115

\* For use of SAE-flanges see this measurement

## Symbols

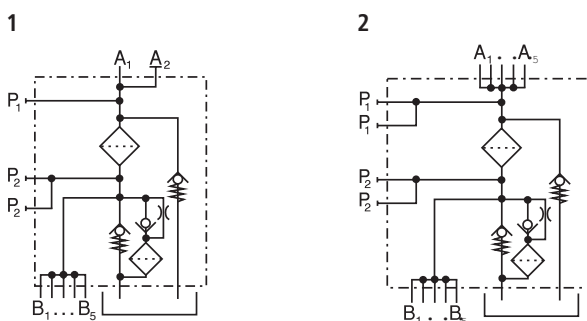

## Spare Parts

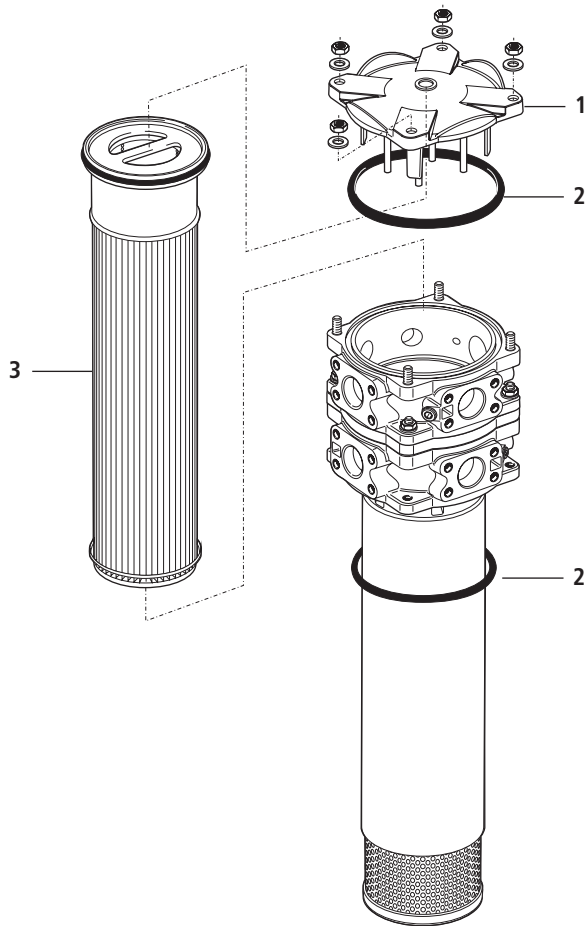

Pos.	Designation	Part No.
1	Cover assy	E 998.1200
2	O-ring 180 x 6	N007.1806
3	Filter element	see Chart / col. 10

The functions of the complete filters as well as the outstanding features of the filter elements assured by ARGO-HYTOS can only be guaranteed if original ARGO-HYTOS spare parts are used.

## Quality Assurance

### Quality management according to DIN EN ISO 9001

To ensure constant quality in production and operation, ARGO-HYTOS filter elements undergo strict controls and tests according to the following ISO standards:

<b>ISO 2941</b>	Verification of collapse/burst pressure rating
<b>ISO 2942</b>	Verification of fabrication integrity (Bubble Point Test)
<b>ISO 2943</b>	Verification of material compatibility with fluids

<b>ISO 3968</b>	Evaluation of pressure drop versus flow characteristics Multi-Pass-Test (evaluation of filter fineness and dirt-holding capacity)
<b>ISO 16889</b>	
<b>ISO 23181</b>	Determination of resistance to flow fatigue using high viscosity fluid

Various quality controls during the production process guarantee the leakfree function and solidity of our filters.

Our engineers will be glad to advise you in questions concerning filter application, selection as well as the cleanliness class of the filtered medium attainable under practical operating conditions.

Illustrations may sometimes differ from the original. ARGO-HYTOS is not responsible for any unintentional mistake in this specification sheet.

### We produce fluid power solutions

ARGO-HYTOS GMBH · Industriestraße 9 · 76703 Kraichtal-Menzingen · Germany  
Phone: +49 7250 76-0 · Fax: +49 7250 76-199 · info@argo-hytos.com · www.argo-hytos.com

Subject to change  
20.98-2e · 0714