



OIL COOLING UNIT

AKJ9 SERIES

Immersion type

AKC9 SERIES

Circulating type

AKJ AKC

9

SERIES



AKJ9 SERIES
Immersion type



AKC9 SERIES
Circulating type

INDEX

AKJ9 SERIES (Immersion type)

Overview / Features	Pages 1 to 2
System Overview Piping System Diagram	Pages 3
Nomenclature	Pages 4
Specifications and Operating range	Pages 5 to 6
Cooling Capacity Characteristic Chart	Pages 7 to 8
External Dimension Diagram	Pages 9 to 11
Installation Dimension Diagram	Pages 12

AKC9 SERIES (Circulating type)

Overview/Features	Pages 13
System Configuration	Pages 13
Nomenclature	Pages 14
Specifications	Pages 14
Cooling Capacity Characteristic Chart	Pages 15
Internal Pressure Loss	Pages 15
Flow Rate Characteristics for Models With a Pump	Pages 15
External Dimension Diagram	Pages 16

Optional Parts

Thermistor	Pages 17
Extension board for main machine communication	Pages 18

Supporting Information

Control Panel	Pages 19
Operation Mode/Setting Method	Pages 20
Electric Schematic Diagram	Pages 21 to 22
Electric Wiring Connection Instruction Diagram	Pages 23
Notes for handling	Pages 24 to 25
Method of selection of Oil Cooling Unit	Pages 26



Overview / Features

Immersion-type oil cooling unit mounted directly on the coolant tank

It is a cooler that is placed on the coolant tank and cools the fluid inside the tank directly with a cooling coil.

* The circulation pump is not provided as an accessory and must be prepared separately by the customer.

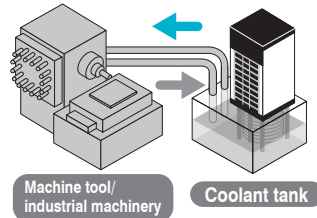

High-accuracy model with the inverter-controlled compressor

The coolant temperature can be controlled within $\pm 0.1^\circ\text{C}$ over the entire cooling load range (from 0 to 100% load) and this helps to increase the accuracy of machine tools.

Further downsizing the industry's top-class compact design

* Comparison in the AKJ459 class (units: mm)

Installation compatibility with conventional products is secured.

Enhanced support for shallow tanks with reduced cooling coil depth

* Comparison in the AKJ359 class (units: mm)

The cooling capacity is equivalent to that of conventional products.

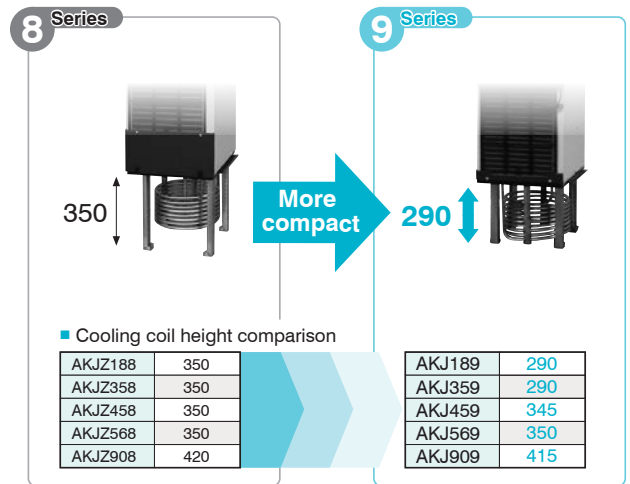
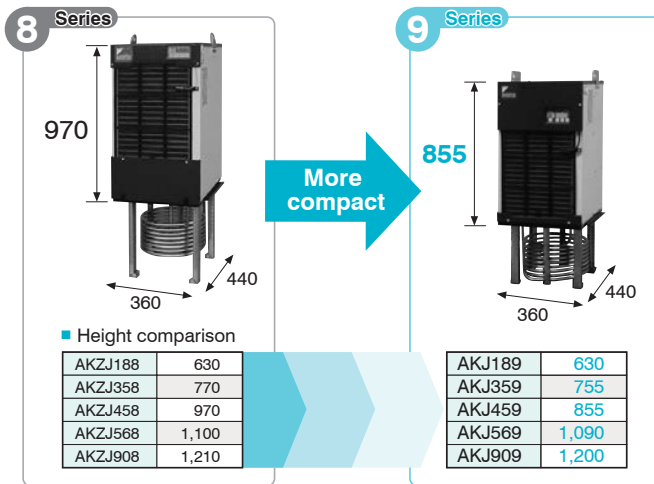

Extension of cooling capacity control range

■ $\pm 0.1^\circ\text{C}$ oil temperature control realized over a load range from 0% (no load) to 100%.

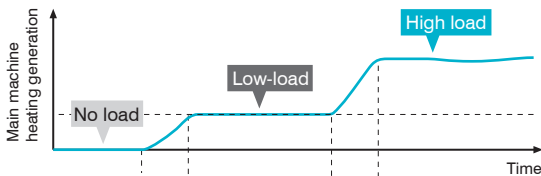

AKJ 9 Series

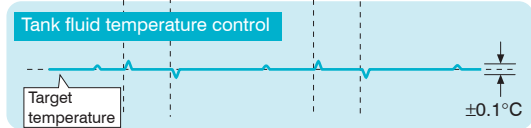

Note: Pattern diagram with the heating load stabilized at 0 - 100%

Achieve high energy-saving performance

■ Achieve high energy-saving performance with the adoption of a Daikin original IPM motor and R410A refrigerant for high COP characteristics.

■ The power consumption can be checked on the operation panel.

* Comparison taking a non-inverter model to have a power consumption of 100
* Measured during the Daikin model operation pattern

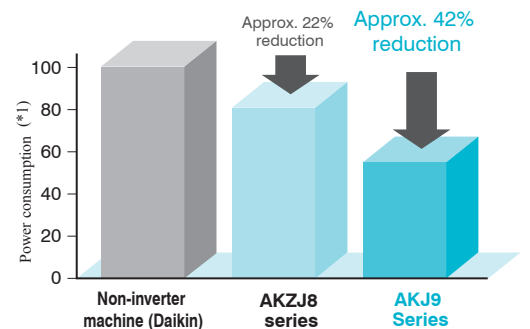

Improved durability/maintainability

- The cooling coil construction suppresses the adhesion and accumulation of cutting/grinding chips.

Increased tolerance of harsh factory conditions including mist and dust

- The ingress protection of the control box has been upgraded (equivalent to IP54).
- Sulfur-free parts have been adopted for electronic components.

Increased tolerance of long-distance transportation

- The specifications for vibration durability during transport have been upgraded to reflect actual transportation conditions.

Predictive maintenance function prevents trouble in advance

- **Predictive maintenance function**
 - A warning signal is output to notify that maintenance is required when the air filter or condenser becomes clogged.
- **3 steps minimizing machine down time**
 - Step 1 Autonomous compensation of overloaded operation
 - Step 2 Notifying the customer about inspection/maintenance by issuing a warning
 - Step 3 Continuing operation in an emergency mode, if operation is possible by restricting some functions and specifications

Simple monitoring of operating status

- The room temperature, tank fluid temperature and other internal data can be monitored at a personal computer using Hybrid-Win*. Operating status can be grasped easily with one list presenting all the data collectively.

* Hybrid-Win is a software tool for monitoring the internal status at a personal computer. You can download the tool itself and its instruction manual free of charge from the website (<http://www.daikinpmc.com>) after registering as a member.

* The communications cable and the monitor harness must be purchased separately.

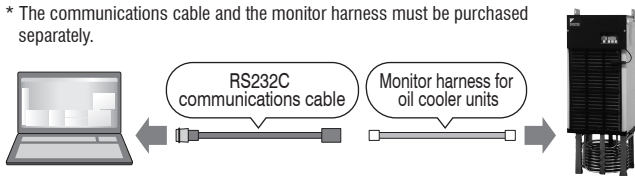

Functions featured

- **Refrigerant gas shortage detection function**
When the refrigerant gas leak status occurs (cooling disabled), alarm signals are output. Prevents damage to the machine and machining defects.
- **Temperature warning function**
A warning signal can be output when the targeted fluid temperature or air temperature was out of the arbitrary setting range.
- **Autotuning function**
This function substantially minimizes trial operation adjustment time by automatically setting the gain when fluid temperature control is not stable with the factory setting or when optimization is required.
- **999-hour timer function (ON timer)**
The operation start time can be set in a range between 0 and 999 hours (in hour units).

RoHS-compliant

- Complies with the RoHS Directive, e.g. by adopting printed circuit boards with lead-free solder.

Four types of optional specification models in addition to the standard model for shorter product delivery terms

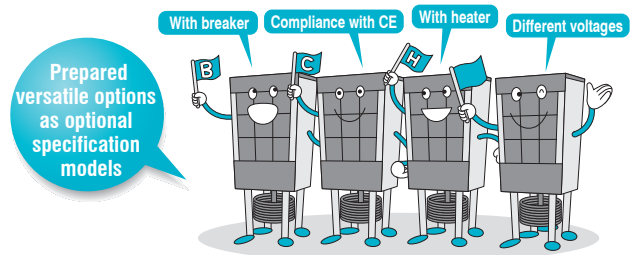

Different voltage specifications (-046, -047, -048)

- The AC 230 V system (-046) has no transformer, while the AC 400 V (-047) and AC 480 V systems (-048) incorporate a transformer inside the product. The installation dimensions and footprint are the same as for the standard models.

Applications

Example of major applications

Machine tools: Machining centers, NC lathes, grinding machines, NC specialized machines, NC electric discharge machines, etc.
Industrial machine: Molding machine, press, etc.

Cooling of hydraulic oil

- Temperature (viscosity) control**
- Prevention of deterioration of hydraulic oil (Longer life)
 - Stabilized operation of actuators

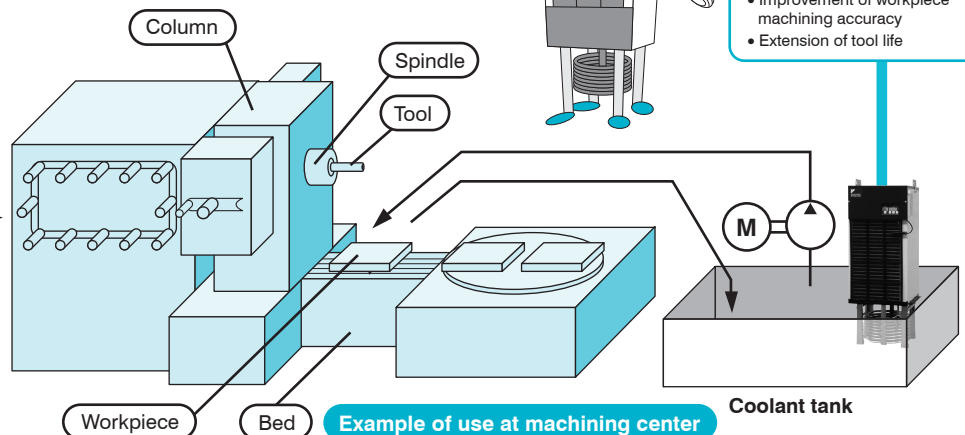
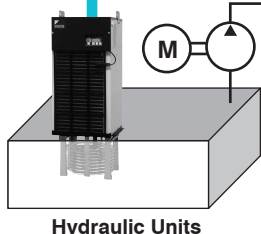

Cooling of cutting oil

- Cooling of workpiece and tool**
- Improvement of workpiece machining accuracy
 - Extension of tool life

Example of use at machining center

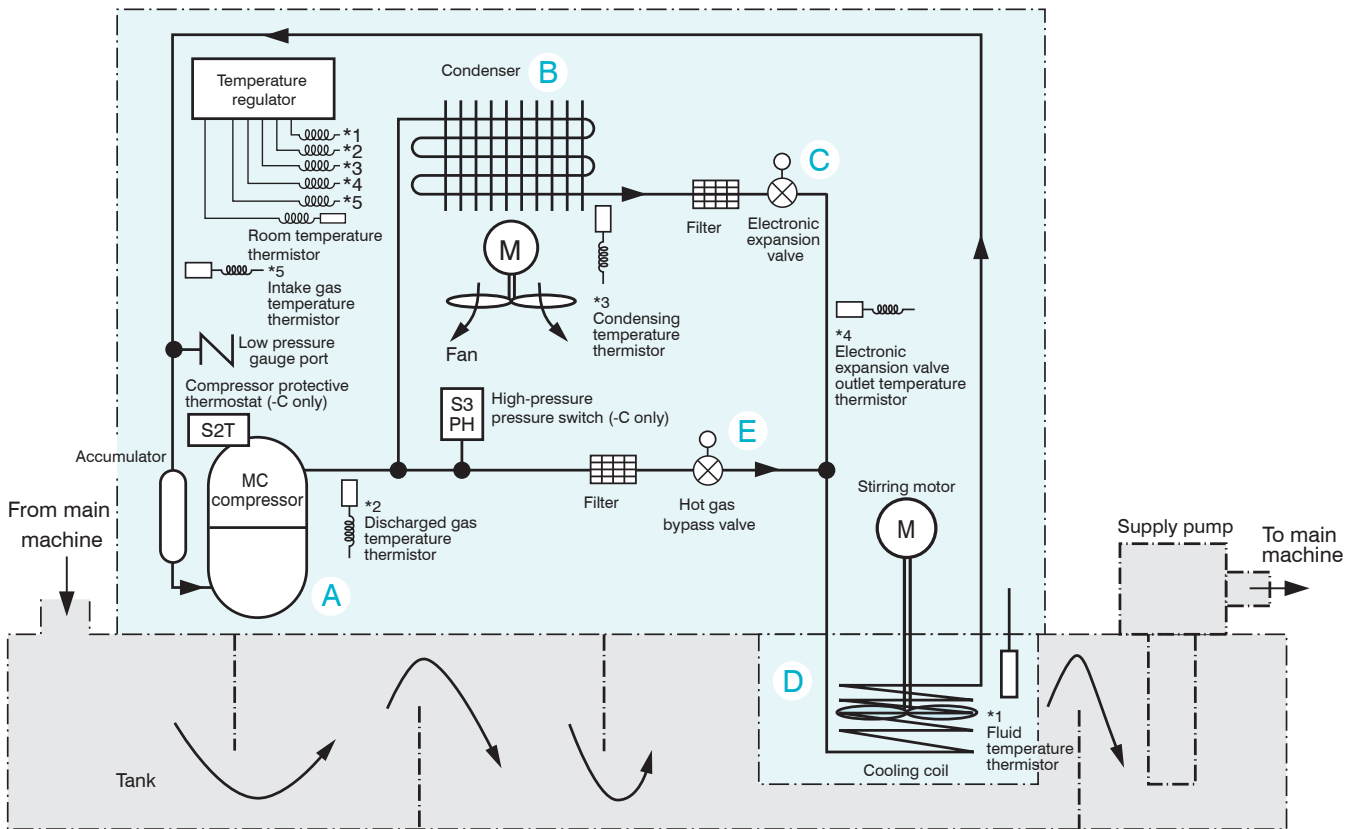

Note: 1. The [] enclosure indicates work that needs to be arranged locally.

2. The heater is only applicable to AKJ-H.

3. The piping system of AKJ1509 differs from that shown in this figure.

■ Refrigerating cycle

- A** : Refrigerant gas is converted into compressed gas at high temperature and high pressure by a compressor so that gas can be easily cooled and liquefied by a condenser.
- B** : In the condenser, the gas at high temperature and high pressure generated in the compressor is cooled with air and converted into liquid at high temperature and high pressure.
- C** : The decompression mechanism (electronic expansion valve) reduces the pressure of the liquid at high temperature and high pressure and converts it into liquid at low temperature and low pressure by throttling it so that it can be easily evaporated in a cooling coil.
- D** : In the cooling coil, liquid at low temperature and low pressure generated in the decompression mechanism absorbs heat from the coolant, evaporates (cools the coolant), and is converted into gas at low temperature and low pressure.
- E** : The hot gas bypass valve controls the cooling capacity at low loads by adjusting the volume of gas at high temperature and high pressure supplied to the cooling coil.

OIL COOLING UNIT

9 AKJ SERIES





1 Oil cooling unit identification code

AKJ : High-accuracy inverter controlled oil cooling unit
Immersion type for cutting/grinding fluid (oil)

2 Cooling capacity (kW)

- 18: Cooling capacity 1.8 kW
- 35: Cooling capacity 3.5 kW
- 45: Cooling capacity 4.5 kW
- 56: Cooling capacity 5.6 kW
- 90: Cooling capacity 9.0 kW
- 150: Cooling capacity 15.0 kW

3 Symbol of series (Symbol to represent model change)

9: "9" series

4 Option Symbol

Options and their combinations
(Refer to the following table.)

Special specifications

-※※※ (3-digit number), C※※※ (3-digit number), etc.
Please consult us about detailed information.

■ Options and their combinations

■ AKJ9 (Immersion type)

Option Symbol	With breaker	Compliance with CE	With heater	Different voltage type (1)	Different voltage type (2)	Different voltage type (3)
-B	✓	—	—	—	—	—
-C	—	✓	—	—	—	—
-H	—	—	✓	—	—	—
-046	—	—	—	✓	—	—
-047	✓	—	—	—	✓	—
-048	✓	—	—	—	—	✓
-BC	✓	✓	—	—	—	—
-BH	✓	—	✓	—	—	—
-CH	—	✓	✓	—	—	—
-BCH	✓	✓	✓	—	—	—
-001	✓	—	—	✓	—	—
-002	—	✓	—	✓	—	—
-003	—	—	✓	✓	—	—
-005	✓	✓	—	✓	—	—
-006	✓	—	✓	✓	—	—
-008	—	✓	✓	✓	—	—
-011	✓	✓	✓	✓	—	—
-017	✓	✓	—	—	✓	—
-018	✓	—	✓	—	✓	—
-023	✓	✓	✓	—	✓	—
-032	✓	✓	—	—	—	✓
-033	✓	—	✓	—	—	✓
-038	✓	✓	✓	—	—	✓

Different voltage type (1) Without transformer AC 220, 230 V 50/60 Hz
 Different voltage type (2) With transformer AC 380, 400, 415 V 50/60 Hz, With breaker
 Different voltage type (3) With transformer AC 440, 460, 480 V 50/60 Hz, With breaker

AKJ189, AKJ359, AKJ459

Oil cooling unit horsepower (HP)		0.5					1.2					1.5					
Model name		AKJ189					AKJ359					AKJ459					
		Standard	-B	-C	-H	Different voltage specifications ³	Standard	-B	-C	-H	Different voltage specifications ³	Standard	-B	-C	-H	Different voltage specifications ³	
Cooling capacity (50/60 Hz) ¹	kW	1.6/1.8					3.2/3.5					4.2/4.5					
Heater	kW	1					1					1					
Supply power ²		Three-phase 200/200•220 VAC 50/60 Hz					Three-phase 200/200•220 VAC 50/60 Hz					Three-phase 200/200•220 VAC 50/60 Hz					
Power voltage	Main circuit																
	Operating circuit	DC12/24 V															
Maximum power consumption/maximum current consumption	When cooling	200 V 50 Hz	0.82 kW/3.3 A				*8	1.37 kW/5.2 A				*8	1.46 kW/5.6 A				*8
		200 V 60 Hz	0.83 kW/3.2 A					1.38 kW/5.1 A					1.48 kW/5.4 A				
		220 V 60 Hz	0.83 kW/3.0 A					1.39 kW/4.8 A					1.48 kW/5.1 A				
	When heating	200 V 50 Hz	1.20 kW/3.8 A				-	1.20 kW/3.8 A				-	1.20 kW/3.8 A				-
		200 V 60 Hz	1.20 kW/3.8 A				-	1.20 kW/3.8 A				-	1.20 kW/3.8 A				-
		220 V 60 Hz	1.44 kW/4.2 A				-	1.44 kW/4.2 A				-	1.44 kW/4.2 A				-
Transformer capacity		2.14 kVA					2.14 kVA					2.14 kVA					
Exterior color		Ivory white															
External dimensions (H × W × D) mm		920 × 360 × 440					1,045 × 360 × 440					1,200 × 360 × 440					
Compressor (Hermetic DC swing type)		Equivalent to 0.4 kW					Equivalent to 0.75 kW					Equivalent to 1.1 kW					
Evaporator		Open coil type															
Condenser		Cross-fin coil type															
Propeller fan	Motor	54 W															
Agitator	Motor	Three phase AC, 60 W, 4 P															
Temperature adjust (Selectable)	Synchronization type	Standard	Room temperature or machine temperature ⁴ (Set to "Room temperature: Mode 3" by default)														
		Object to be controlled	Tank fluid temperature														
	Synchronization range	K															
	Fixed type	Object to be controlled	-9.9 to +9.9 against the standard temperature (Set at 0.0 by default)														
Oil temperature controller resolution	Range	Tank fluid temperature															
		°C															
Capacity control range		5 to 50															
Timer function		0 to 100%															
Refrigerant control		ON timer: 1 to 999 hours (1-hour unit setting)															
Refrigerant (R410A) ⁵ Filling amount	kg	0.55					0.76					0.99					
Protection devices/protective functions		Agitator internal thermostat, discharge pipe temperature thermostat, condenser temperature thermostat, reverse-phase protection device, restart prevention timer, low room temperature protection thermostat, high fluid temperature protection thermostat, low fluid temperature protection thermostat, refrigerant leakage detector, inverter protection device set, circuit breaker (-B type only), high-pressure pressure switch (-C type only), compressor protection thermostat (-C type only), heating prevention temperature switch (-H type only), and temperature fuse (-H type only).															
Operating range	Room temperature	°C															
	Tank fluid temperature	5 to 45															
	Oil viscosity	mm ² /s															
Acceptable fluid		Water-soluble cutting/grinding fluid, cutting/grinding oil, lubrication oil, hydraulic oil, industrial water (Cannot be used for drugs, food products, and fuel)															
Operating sound (value equivalent to measurement in an anechoic chamber) (Front 1 m, height 1 m)	dB(A)	62															
Transport vibration performance		Up and down vibration 14.7 m/s ² (1.5 G) × 2.5 hr (7.5 to 100 Hz sweep/five min.)															
Protective structure ⁶		IP2X															
Mass	kg	38					44					50					
Molded-case circuit breaker (Rated current)	A	10					10					10					
Items prepared by the customer		Molded-case circuit breaker (Rated current) A															
		10 (Required for types other than -B type) ⁷															
		Device other than molded-case circuit breaker															
		Tank, supply pump, float switch, return filter															

- Note: *1. The cooling capacity indicates the value at the standard point (tank fluid temperature: 35°C, room temperature: 35°C, fluid used: ISO VG32). This unit has about ±5% of product tolerance.
- *2. Use a commercial power supply for the power source. The use of an inverter power supply may cause burn damage to the machine. The voltage fluctuation range should be within ±10%. If the voltage fluctuation range is more than ±10%, please consult us.
- *3. There are the following three types of different voltage specifications.
 AC220, 230 V : Option code -046 (without transformer)
 AC380, 400, 415 V : Option code -047 (with built-in transformer)
 AC440, 460, 480 V : Option code -048 (with built-in transformer)
 The main circuit voltage is the transformer's secondary side voltage of AC 200 V, 50/60 Hz.
 (-046 units have no transformer and therefore have the same external dimensions and mass as standard units. Their main circuit voltage is 220/230 VAC, 50/60 Hz.)
- *4. The optional thermistor for machine temperature synchronization is required. (Refer to Page 17 for details.)
- *5. The SDS (Safety Data Sheet) of refrigerant R410A is attached to the -C type.
- *6. Electric component box ingress protection: IP54 or equivalent (However, use piping conduits etc. rated at least IP54 at wiring ports.)
- *7. The molded-case circuit breaker is not supplied with this product. Please prepare it yourself.
- *8. The maximum power consumption/maximum current consumption of different voltage specifications are shown in the tables below.

■ AKJ189		■ AKJ359		■ AKJ459		■ AKJ569		■ AKJ909		■ AKJ1509	
Supply power	Power/current	Supply power	Power/current	Supply power	Power/current	Supply power	Power/current	Supply power	Power/current	Supply power	Power/current
220V 50Hz	0.82kW 3.0A	220V 50Hz	1.38kW 4.8A	220V 50Hz	1.48kW 5.1A	220V 50Hz	2.92kW 9.0A	220V 50Hz	3.41kW 10.3A	220V 50Hz	5.38kW 15.8A
60Hz	0.83kW 3.0A	60Hz	1.38kW 4.8A	60Hz	1.48kW 5.1A	60Hz	2.83kW 8.9A	60Hz	3.43kW 10.2A	60Hz	5.40kW 15.7A
230V 50Hz	0.82kW 2.9A	230V 50Hz	1.39kW 4.6A	230V 50Hz	1.46kW 4.9A	230V 50Hz	2.92kW 8.6A	230V 50Hz	3.41kW 9.9A	230V 50Hz	5.38kW 15.4A
60Hz	0.83kW 2.8A	60Hz	1.38kW 4.6A	60Hz	1.48kW 4.7A	60Hz	2.83kW 8.3A	60Hz	3.44kW 9.8A	60Hz	5.41kW 15.3A
380V	1.8A	380V	2.8A	380V	3.0A	380V	4.9A	380V	5.7A	380V	9.1A
400V	1.7A	400V	2.6A	400V	2.8A	400V	4.7A	400V	5.4A	400V	8.7A
415V	1.7A	415V	2.5A	415V	2.7A	415V	4.5A	415V	5.2A	415V	8.4A
50/60Hz	0.83kW	50/60Hz	1.38kW	50/60Hz	1.48kW	50/60Hz	2.77kW	50/60Hz	3.43kW	50/60Hz	5.40kW
440V	1.5A	440V	2.4A	440V	2.6A	440V	4.3A	440V	4.9A	440V	7.9A
460V	1.5A	460V	2.3A	460V	2.5A	460V	4.1A	460V	4.7A	460V	7.5A
480V	1.4A	480V	2.2A	480V	2.4A	480V	3.9A	480V	4.5A	480V	7.3A

AKJ569, AKJ909, AKJ1509

Oil cooling unit horsepower (HP)		2.0					3.0					5.0					
Model name		AKJ569					AKJ909					AKJ1509					
		Standard	-B	-C	-H	Different voltage specifications ³⁾	Standard	-B	-C	-H	Different voltage specifications ³⁾	Standard	-B	-C	-H	Different voltage specifications ³⁾	
Cooling capacity (50/60 Hz) ¹⁾	kW	5.0/5.6					8.0/9.0					15.0/15.0					
Heater	kW	2					4					4					
Supply power ²⁾		Three-phase 200/200·220 VAC 50/60 Hz					Three-phase 200/200·220 VAC 50/60 Hz					Three-phase 200/200·220 VAC 50/60 Hz					
Power voltage	Main circuit	Three-phase 200/200·220 VAC 50/60 Hz															
	Operating circuit	DC12/24 V															
Maximum power consumption/maximum current consumption	When cooling	200V 50 Hz	2.77 kW/9.4 A				*8	3.38 kW/10.8 A				*8	5.40 kW/17.3 A				*8
		200V 60 Hz	2.72 kW/9.2 A					3.43 kW/10.7 A					5.37 kW/16.9 A				
		220V 60 Hz	2.83 kW/8.9 A					3.43 kW/10.2 A					5.40 kW/15.7 A				
	When heating	200V 50 Hz	2.32 kW/7.1 A				-	4.42 kW/13.1 A				-	4.60 kW/13.8 A				-
		200V 60 Hz	2.33 kW/7.1 A				-	4.45 kW/13.1 A				-	4.60 kW/13.7 A				-
		220V 60 Hz	2.79 kW/7.8 A				-	5.33 kW/14.4 A				-	5.49 kW/14.9 A				-
Transformer capacity		-				2.79 kVA	-				5.02 kVA	-				7.7 kVA	
Exterior color		Ivory white															
External dimensions (H × W × D) mm		1,440 × 470 × 500					1,615 × 560 × 620					1,960 × 735 × 725					
Compressor (Hermetic DC swing type)		Equivalent to 1.5 kW					Equivalent to 2.2 kW					Equivalent to 1.5 kW + equivalent to 2.2 kW					
Evaporator		Open coil type															
Condenser		Cross-fin coil type															
Propeller fan	Motor	100 W										100 W × 2					
Agitator	Motor	Three phase AC, 60 W, 4P															
Temperature adjust (Selectable)	Synchronization Type	Standard	Room temperature or machine temperature ⁴⁾ (Set to "Room temperature: Mode 3" by default)														
		Object to be controlled	Tank fluid temperature														
	Synchronization range	-9.9 to +9.9 against the standard temperature (Set at 0.0 by default)															
	Fixed Type	Object to be controlled	Tank fluid temperature														
Range		5 to 50															
Oil temperature controller resolution		±0.1°C															
Capacity control range		0 to 100%															
Timer function		ON timer: 1 to 999 hours (1-hour unit setting)															
Refrigerant control		Compressor revolutions by inverter + Opening of electric expansion valve															
Refrigerant (R410A) ⁵⁾ Filling amount	kg	1.07					1.58					2.65					
Protection devices/protective functions		Agitator internal thermostat, discharge pipe temperature thermostat, condenser temperature thermostat, reverse-phase protection device, restart prevention timer, low room temperature protection thermostat, high fluid temperature protection thermostat, low fluid temperature protection thermostat, refrigerant leakage detector set, circuit breaker (-B type only), high-pressure pressure switch (-C type only), compressor protection thermostat (-C type only), heating prevention temperature switch (-H type only), and temperature fuse (-H type only).															
Operating range	Room temperature	5 to 45															
	Tank fluid temperature	5 to 50															
	Oil viscosity	0.5 to 200															
Acceptable fluid		Water-soluble cutting/grinding fluid, cutting/grinding oil, lubrication oil, hydraulic oil, industrial water (Cannot be used for drugs, food products, and fuel)															
Operating sound (value equivalent to measurement in an anechoic chamber) (Front 1 m, height 1 m)	dB(A)	65					68					69					
Transport vibration performance		Up and down vibration 14.7 m/s ² (1.5 G) × 2.5 hr (7.5 to 100 Hz sweep/five min.)															
Protective structure ⁶⁾		IP2X															
Mass	kg	72	75	97	89	93	117	140	144	180							
Molded-case circuit breaker (Rated current)	A	-	15	-	-	20	-	30	-								
Items prepared by the customer	Molded-case circuit breaker (Rated current)	15 (Required for types other than the -B type) ⁷⁾					20 (Required for types other than the -B type) ⁷⁾					30 (Required for types other than the -B type) ⁷⁾					
	Device other than molded-case circuit breaker	Tank, supply pump, float switch, return filter															

Refer to Page 5 for explanatory notes.

Operating range

- Note: 1. The mark © shows the standard point.
 2. Be sure to use the unit within the range of use specified in .
 (Use outside this range may cause unit failure.)

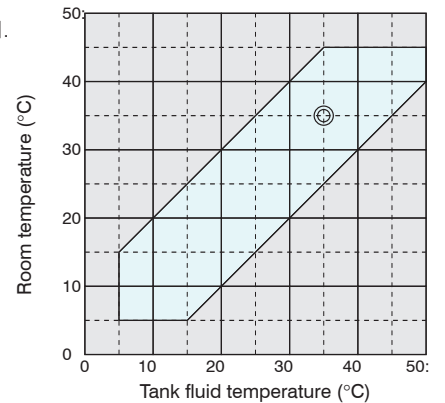

AKJ189

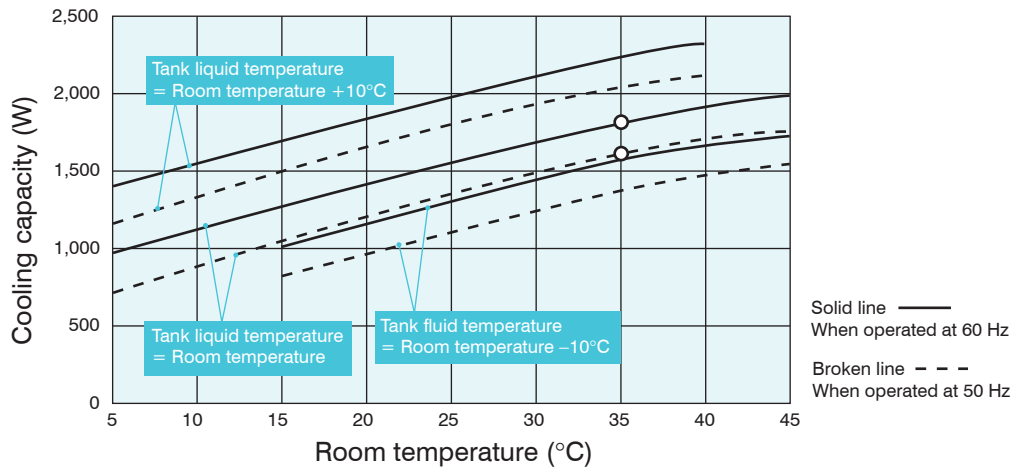

AKJ359

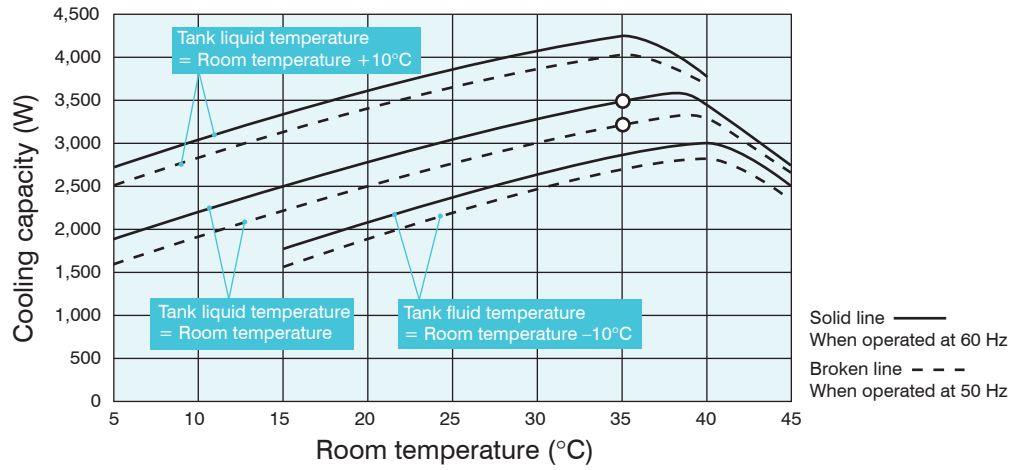

AKJ459

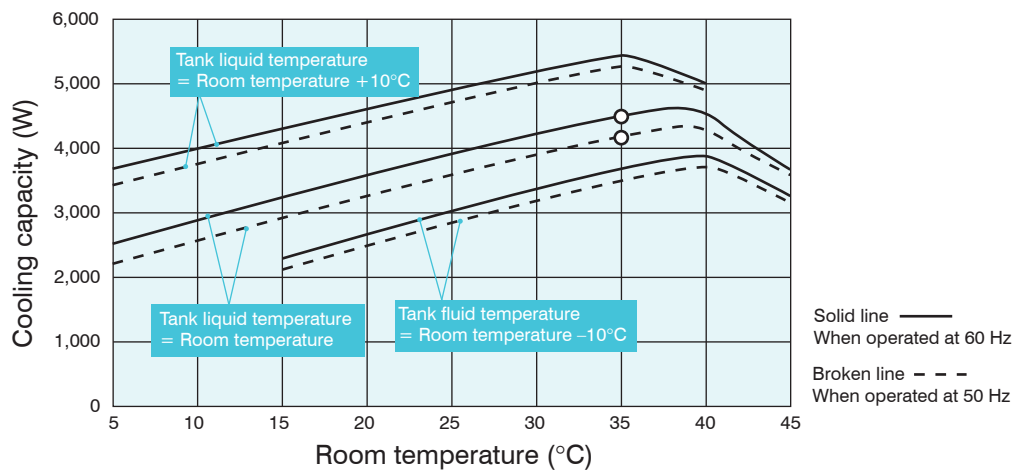

AKJ569

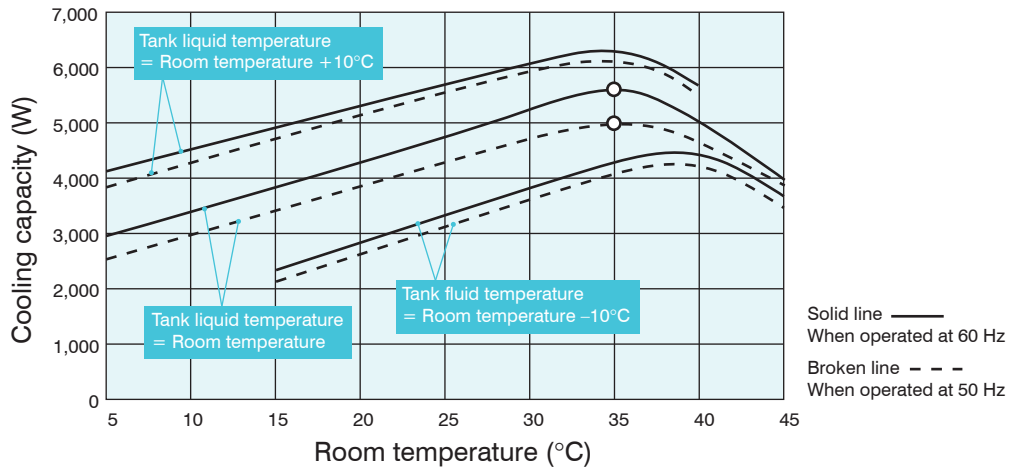

AKJ909

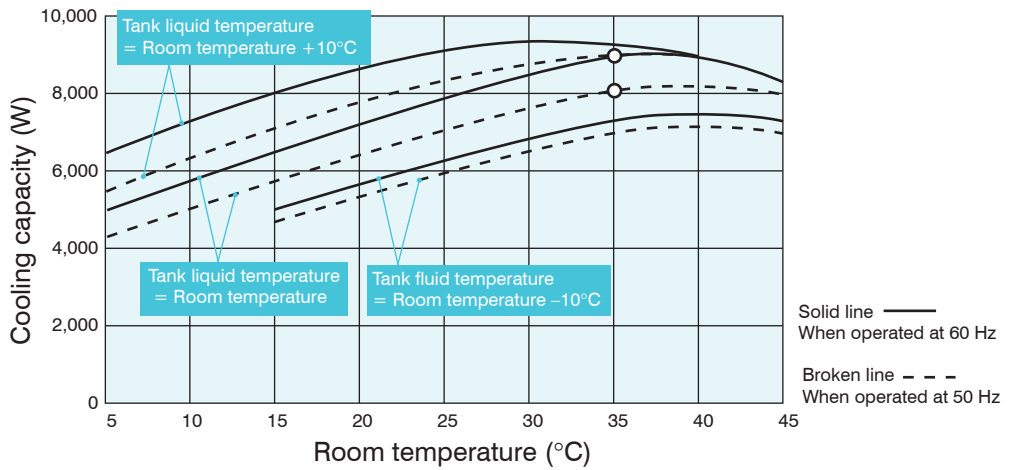

AKJ1509

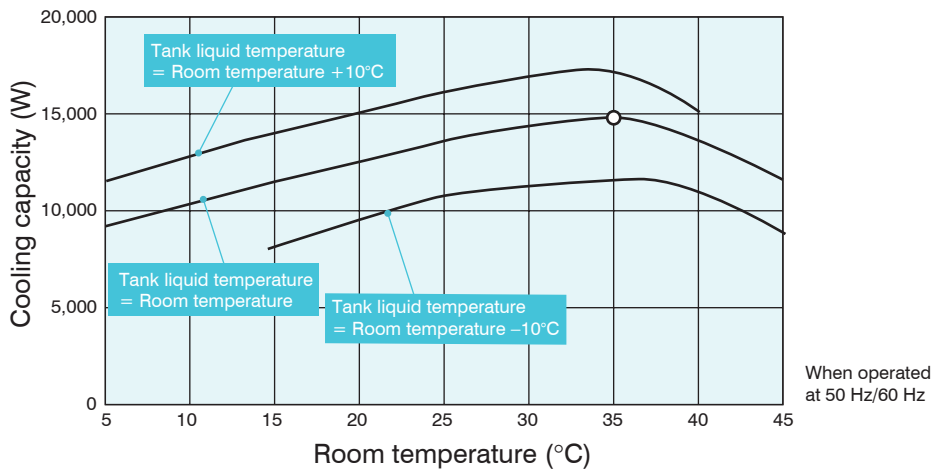

1. The O symbol indicates the standard point. (Room temperature: 35°C/ tank fluid temperature: 35°C/ oil used: ISO VG32)
2. The cooling capacity varies depending on conditions including the room temperature, tank fluid temperature and the kinematic viscosity of the oil, etc.

External Dimension Diagram

The positions of the bolt holes used for installing the product on the tank top plate are compatible with the AKZJ8 series, but the positions of the power supply/signal cable inlet ports are not.

Note: Refer to Page 5 for more details.

• For the machining dimensions of the holes for installation on the tank, refer to page 12.

AKJ189 (-B, -C, -H, -046, -047, -048)

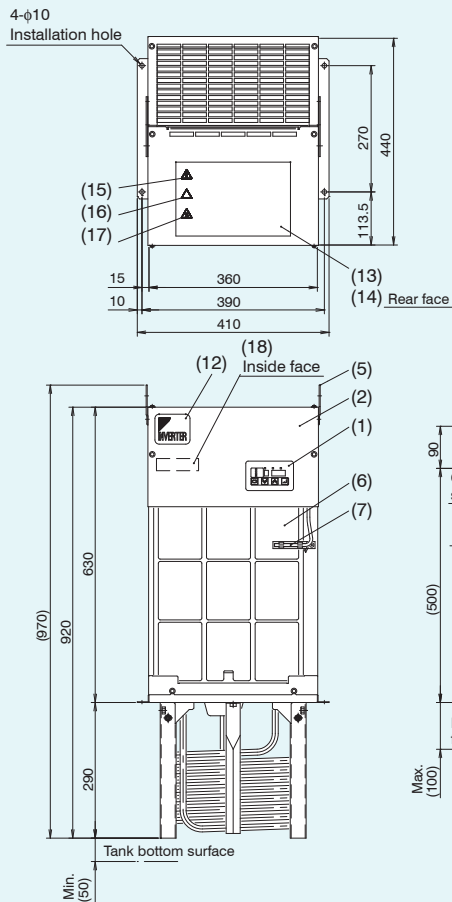

Part No.	Name	Description
1	Control panel	
2	Electrical component box lid	
3	Power supply inlet (Right / Left)	φ28-mm hole Except for different voltage options -047, -048
4	Signal line inlet (Right / Left)	φ22 hole
5	Eye plate	φ25 hole
6	Air filter	
7	Room temperature thermistor	
8	Fluid temperature thermistor	
9	Cooling coil	
10	Agitating plate	

Part No.	Name	Description
11	Machine nameplate	
12	Design nameplate	
13	Overall caution plate	
14	Electric schematic diagram nameplate	
15	Battery charge mark nameplate	
16	Cutting injury caution nameplate	
17	High temperature caution nameplate	
18	Model name nameplate	
19	19 Heater	Only for models with heater
20	Power supply inlet	φ28-mm hole For different voltage options -047, -048 only

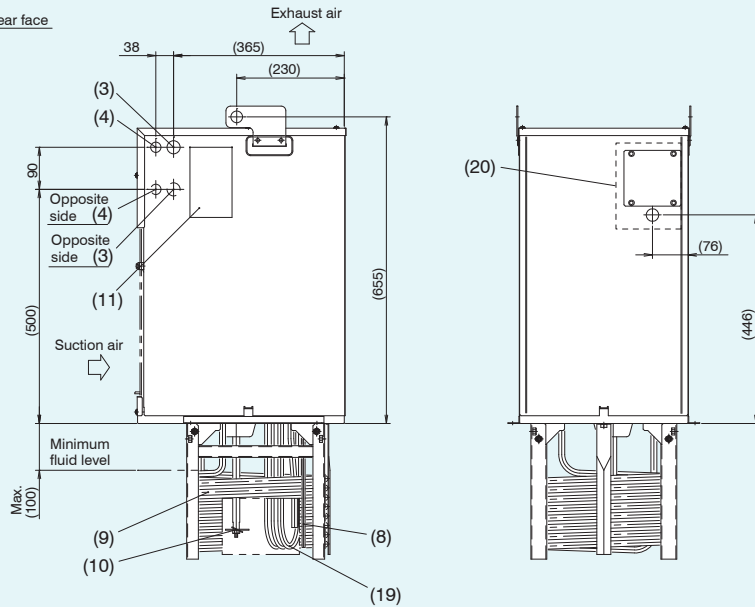

AKJ359 (-B, -C, -H, -046, -047, -048)

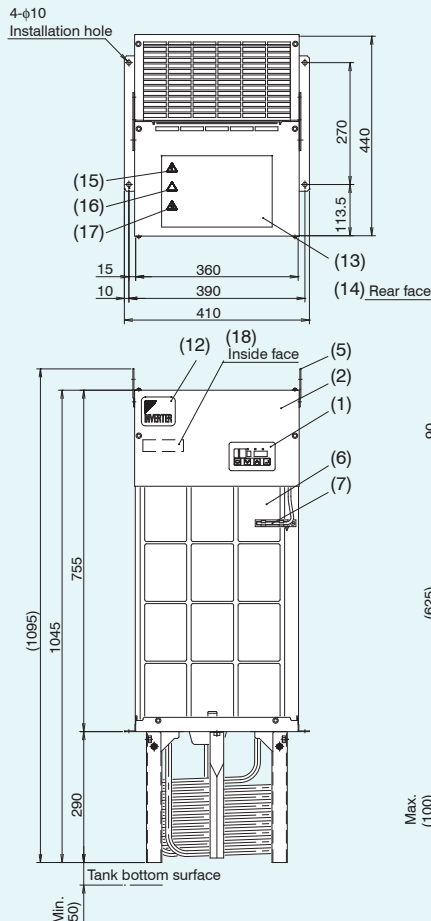

Part No.	Name	Description
1	Control panel	
2	Electrical component box lid	
3	Power supply inlet (Right / Left)	φ28-mm hole Except for different voltage options -047, -048
4	Signal line inlet (Right / Left)	φ22 hole
5	Eye plate	φ25 hole
6	Air filter	
7	Room temperature thermistor	
8	Fluid temperature thermistor	
9	Cooling coil	
10	Agitating plate	

Part No.	Name	Description
11	Machine nameplate	
12	Design nameplate	
13	Overall caution plate	
14	Electric schematic diagram nameplate	
15	Battery charge mark nameplate	
16	Cutting injury caution nameplate	
17	High temperature caution nameplate	
18	Model name nameplate	
19	Heater	Only for models with heater
20	Power supply inlet	φ28-mm hole For different voltage options -047, -048 only

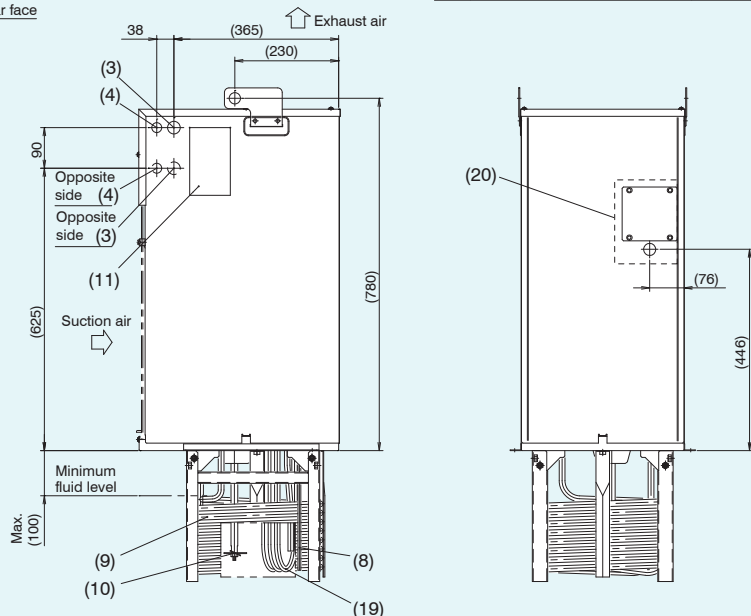

AKJ459 (-B, -C, -H, -046, -047, -048)

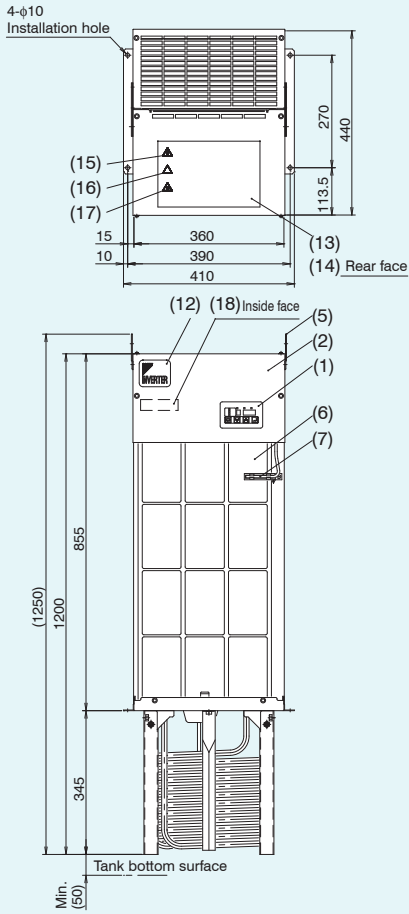

Part No.	Name	Description
1	Control panel	
2	Electrical component box lid	
3	Power supply inlet (Right / Left)	φ28-mm hole Except for different voltage options -047, -048
4	Signal line inlet (Right / Left)	φ22 hole
5	Eye plate	φ25 hole
6	Air filter	
7	Room temperature thermistor	
8	Fluid temperature thermistor	
9	Cooling coil	
10	Agitating plate	

Part No.	Name	Description
11	Machine nameplate	
12	Design nameplate	
13	Overall caution plate	
14	Electric schematic diagram nameplate	
15	Battery charge mark nameplate	
16	Cutting injury caution nameplate	
17	High temperature caution nameplate	
18	Model name nameplate	
19	Heater	Only for models with heater
20	Power supply inlet	φ28-mm hole For different voltage options -047, -048 only

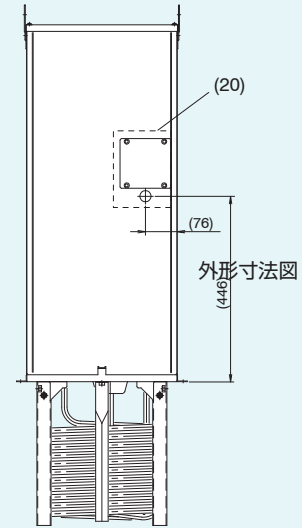
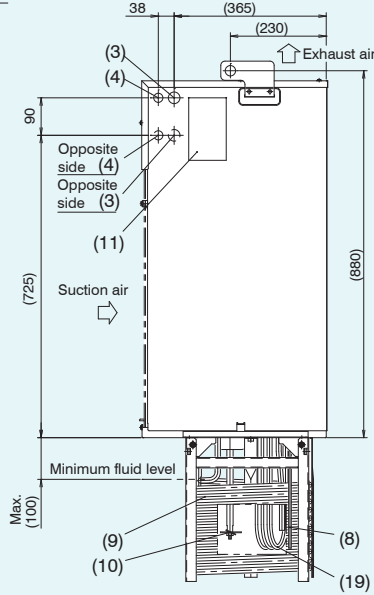

AKJ569 (-B, -C, -H, -046, -047, -048)

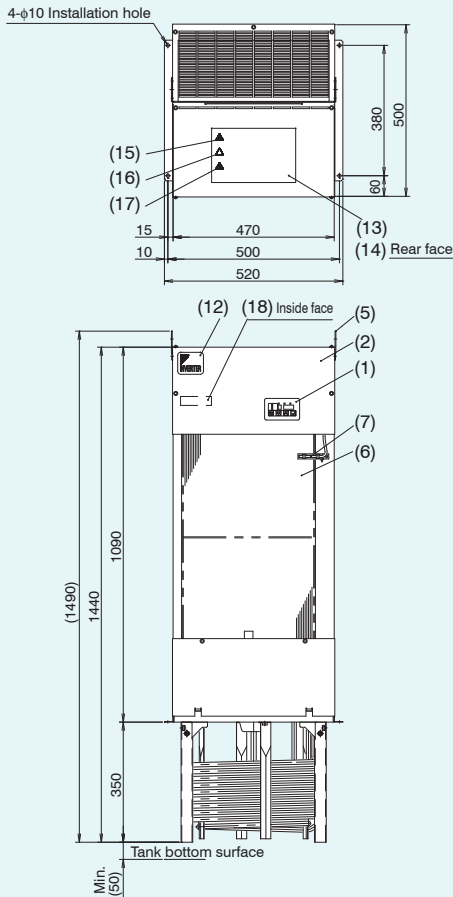

Part No.	Name	Description
1	Control panel	
2	Electrical component box lid	
3	Power supply inlet (Right / Left)	φ28-mm hole Except for different voltage options -047, -048
4	Signal line inlet (Right / Left)	φ22 hole
5	Eye plate	φ25 hole
6	Air filter	
7	Room temperature thermistor	
8	Fluid temperature thermistor	
9	Cooling coil	
10	Agitating plate	

Part No.	Name	Description
11	Machine nameplate	
12	Design nameplate	
13	Overall caution plate	
14	Electric schematic diagram nameplate	
15	Battery charge mark nameplate	
16	Cutting injury caution nameplate	
17	High temperature caution nameplate	
18	Model name nameplate	
19	Heater	Only for models with heater
20	Power supply inlet	φ28-mm hole For different voltage options -047, -048 only

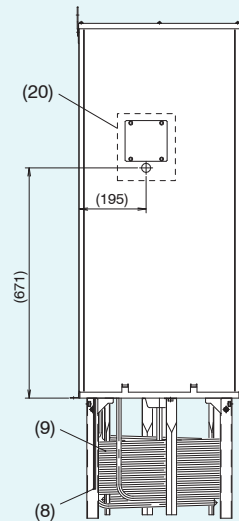
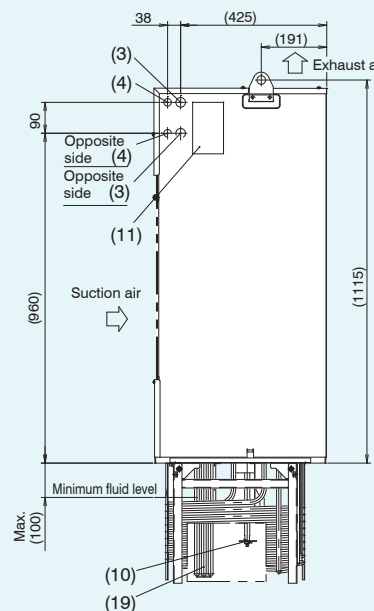

External Dimension Diagram

Note: Refer to Page 5 for more details.

• For the machining dimensions of the holes for installation on the tank, refer to page 12.

The positions of the bolt holes used for installing the product on the tank top plate are compatible with the AKZJ8 series, but the positions of the power supply/signal cable inlet ports are not.

AKJ909 (-B, -C, -H, -046, -047, -048)

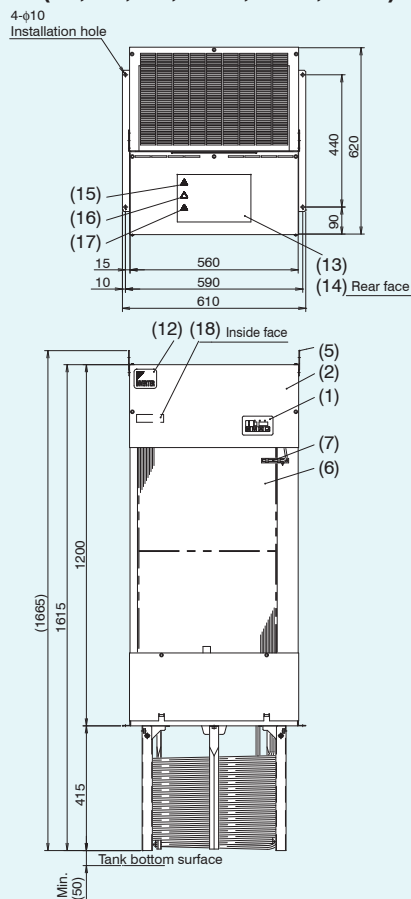

Part No.	Name	Description
1	Control panel	
2	Electrical component box lid	
3	Power supply inlet (Right / Left)	φ28-mm hole Except for different voltage options -047, -048
4	Signal line inlet (Right / Left)	φ22 hole
5	Eye plate	φ25 hole
6	Air filter	
7	Room temperature thermistor	
8	Fluid temperature thermistor	
9	Cooling coil	
10	Agitating plate	

Part No.	Name	Description
11	Machine nameplate	
12	Design nameplate	
13	Overall caution plate	
14	Electric schematic diagram nameplate	
15	Battery charge mark nameplate	
16	Cutting injury caution nameplate	
17	High temperature caution nameplate	
18	Model name nameplate	
19	Heater	Only for models with heater
20	Power supply inlet	φ28-mm hole For different voltage options -047, -048 only

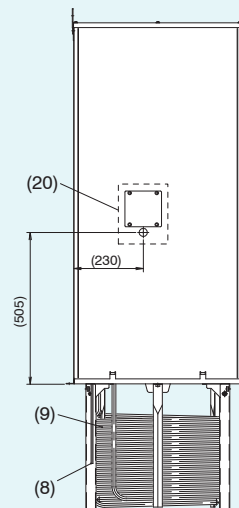
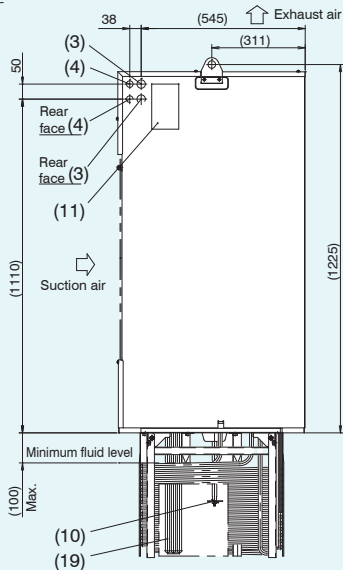

AKJ1509 (-B, -C, -H, -046, -047, -048)

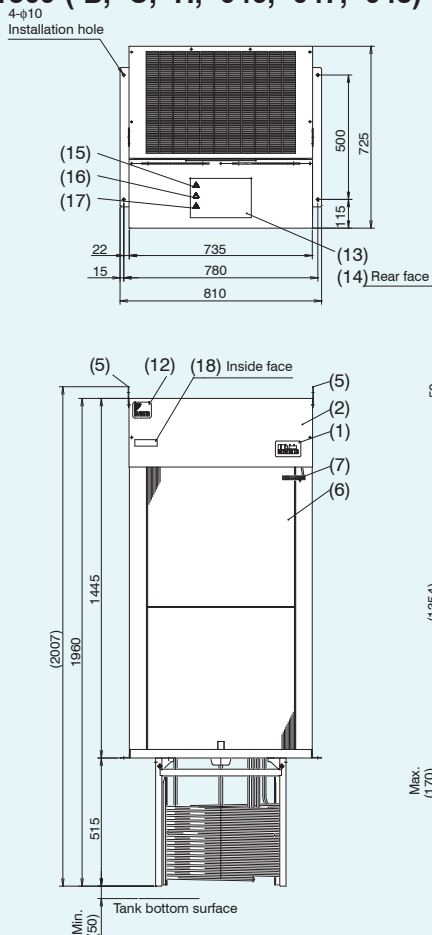

Part No.	Name	Description
1	Control panel	
2	Electrical component box lid	
3	Power supply inlet (Right / Left)	φ28-mm hole Except for different voltage options -047, -048
4	Signal line inlet (Right / Left)	φ22 hole
5	Eye plate	φ25 hole
6	Air filter	
7	Room temperature thermistor	
8	Fluid temperature thermistor	
9	Cooling coil	
10	Agitating plate	

Part No.	Name	Description
11	Machine nameplate	
12	Design nameplate	
13	Overall caution plate	
14	Electric schematic diagram nameplate	
15	Battery charge mark nameplate	
16	Cutting injury caution nameplate	
17	High temperature caution nameplate	
18	Model name nameplate	
19	Heater	Only for models with heater
20	Power supply inlet	φ28-mm hole For different voltage options -047, -048 only

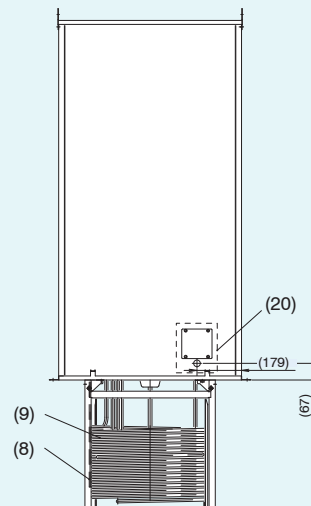
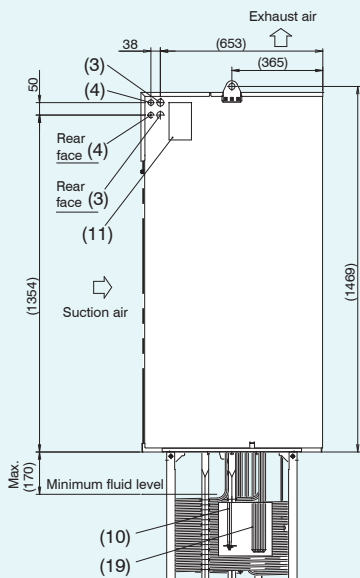

• Notes for manufacturing of tank

1. Separate the fluid tank into at least three sections. Use the over-flow system and take measures so that foreign matter such as cutting chips and debris does not get into the suction line directly.
2. Arrange and locate the partition plates and piping position properly so that high-temperature fluid returned from the main machine and low-temperature fluid cooled by the Oil Cooling Unit are evenly mixed.
3. Design the tank so that the tank inside can be cleaned with ease (For instance, the tank upper plate can be removed).
4. Tank material: Stainless steel is recommended, but compatibility with the cooling fluid should be adequately considered. (Some grinding fluid tanks are made of general structural steel with the interior coated with epoxy resin.)

• Dimensions of installation tank (Plan view)

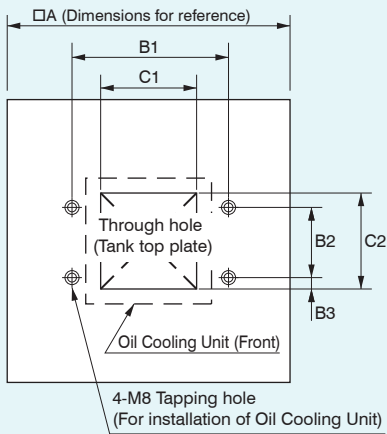

Oil Cooling Unit series	Tank Size	Depth H	Tank hole pitch			Through hole		Installation Compatibility (✓: Compatible)	
			B1	B2	B3	C1	C2	With 8 Series	With 7 Series
AKJ 189		340 or more	390	270	15	325	325	✓ AKZJ188	Note: ✓ AKZJ187
AKJ 359	600 or more	395 or more						✓ AKZJ358	Note: ✓ AKZJ357
AKJ 459								✓ AKZJ458	-
AKJ 569	700 or more	400 or more	500	380	45	440	440	✓ AKZJ568	✓ AKZJ567
AKJ 909	800 or more	465 or more	590	440	30	500	500	✓ AKZJ908	✓ AKZJ907
AKJ1509	1000 or more	565 or more	780	500	30	560	560	-	-

Note: The Oil Cooling Unit projects beyond the tank about 50 mm to the front. (It is necessary to check whether there is any obstruction to the front.)

Part No.	Name	Q'ty/unit	Part No.	Name	Q'ty/unit
1	Oil cooling unit	1	7	Return port	1
2	Tank body	1	8	Tank drain	1
3	Tank top plate	1	9	Float switch	1
4	Tank packing	1	10	Oil filler port-cum-air breather	1
5	Supply pump	1	11	Oil level gauge	1
6	Discharge port	1	12	Hanging bolt	4

Note: Part Nos. 2 to 12 are not included in the scope of Daikin's products.

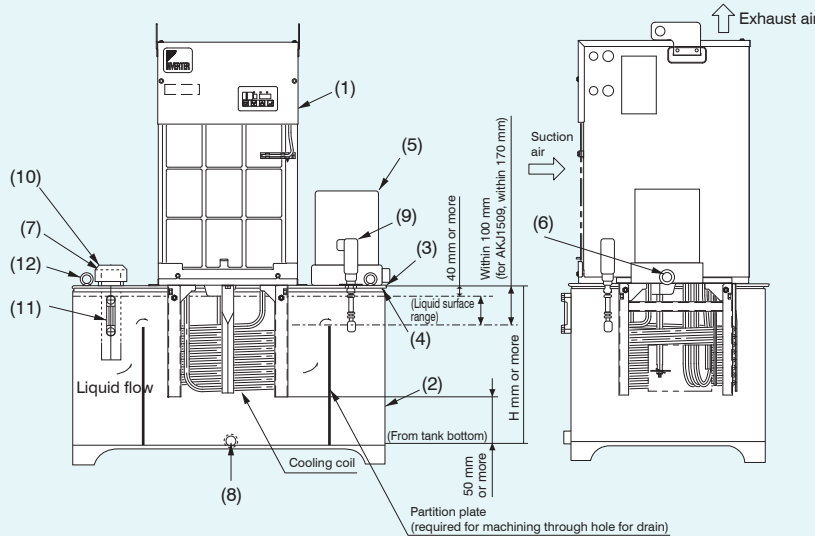

1. Ensure that the fluid surface is in the range of 40 to 100 mm from the top plate of the tank (for AKJ1509, 40 to 170 mm).
2. Do not expose the cooling coil extending above the fluid surface.
3. The height of the partition plate should be higher than the lowest fluid level of the fluid level range

• Separate type When the depth of the tank is the "H" dimension in the figure above or less

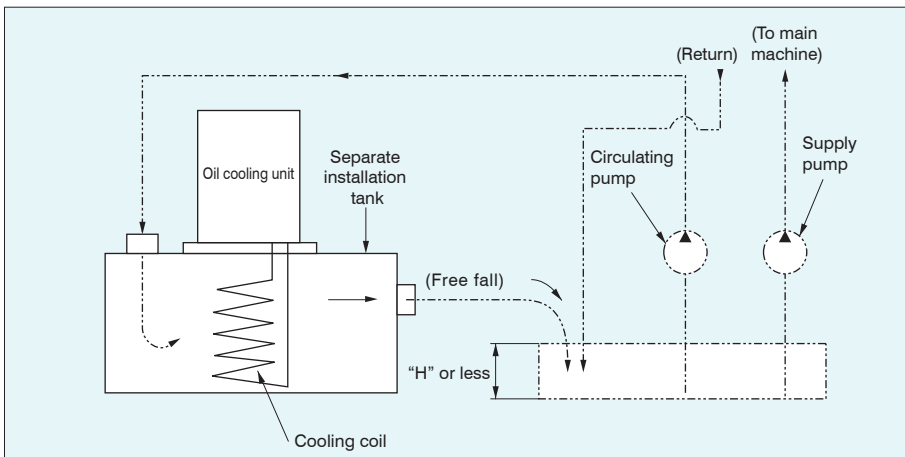

1. If it is expected that cutting chips and debris will get into the tank, install efficient filters in the supply or return line.
2. If foreign matter such as cutting chips and debris deposit on and adhere to the cooling coil surface, the cooling capacity is deteriorated and this may result in failure.

Overview / Features

Inline type cooling unit for coolant

The inline type unit can be installed with only piping regardless of the depth of the coolant tank.

This unit also can be used for retrofitting in an existing tank.

Optional models with a built-in pump are also available.

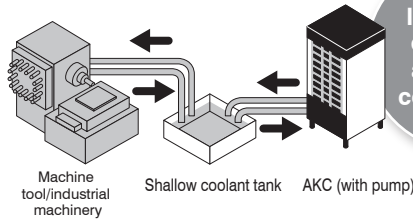

Installable even with a shallow coolant tank



Highly accurate temperature control model by inverter control

The coolant temperature can be controlled within $\pm 0.1^{\circ}\text{C}$ over the entire cooling load range (from 0 to 100% load) and this helps to increase the accuracy of machine tools.

Excellent energy savings

A Daikin original high efficiency IPM motor is adopted on the compressor. High energy savings are realized with inverter control technology built up through our air conditioning experience and R410A refrigerant that has high COP characteristics.

(Approx. 30% energy savings compared to the 8 Series)

Complies with RoHS Directives such as Lead-Free (Environmentally friendly unit)

The environmental load has been reduced in conformance with the RoHS Directive by restricting hazardous substances to levels below the reference value, etc.

Easy maintenance

The evaporator coil design has been improved to give more durability against clogging. It is also easy to disassemble and clean the evaporator coil.

Greater durability against oil mist and dust

Ingress protection range for the control box is improved, including upgrade to IP54 and adoption of sulfur-free parts.

Simple monitoring of operating status

Alarm information, operation time, etc., can be monitored from a personal computer.

- This is useful for speeding up the identification of parts that need maintenance according to the “Alarm information” readout and shortening machine down times.
- The “Operation time” is a guide to determining the replacement timing for consumables and maintenance intervals.

* Monitoring from a personal computer requires a software tool (Hybrid-Win), the communications cable and the monitor harness.

* Hybrid-Win and the instruction manual can be downloaded free of charge from our website (<http://www.daikinpmc.com>) after user registration.

* The communications cable and the monitor harness must be purchased separately.

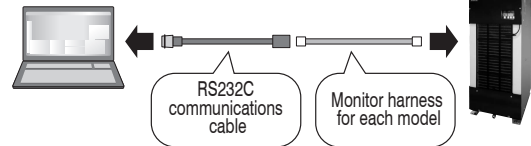

3 options available in addition to standard specifications

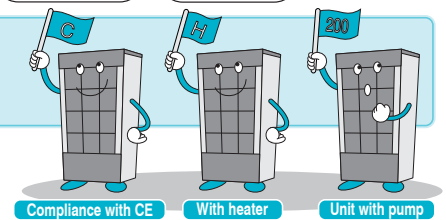

System Configuration

Easy retrofit into the existing tank

Evaporator improved for greater durability against clogging

Unit without pump

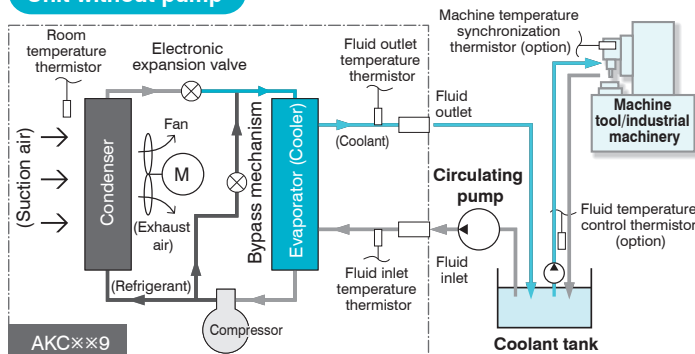

Unit with pump

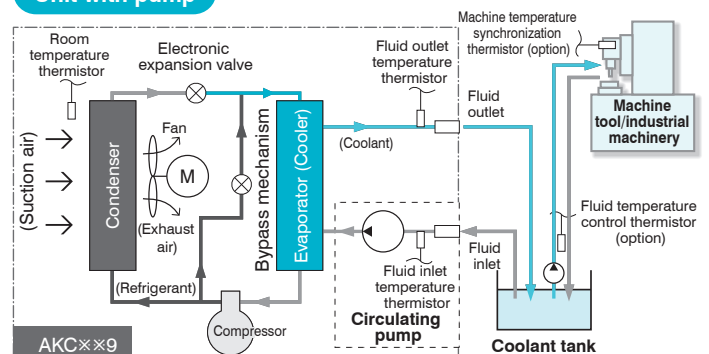

AKC	✖✖	9	-✖✖✖
1	2	3	4

1 Oil cooling unit identification code

AKC: High-accuracy inverter controlled oil cooling unit [Coolant circulating type]

2 Cooling capacity

35: Cooling capacity of 3.5 kW
56: Cooling capacity of 5.6 kW

3 Symbol of series (Symbol to represent model change)

9: "9" series

4 Symbol of option type (C/H/200)/Non-standard number

Options and their combinations

Option Symbol	Compliance with CE	With heater	Unit with pump
-C	✓	-	-
-H	-	✓	-
-200	-	-	✓
-CH	✓	✓	-
C200	✓	-	✓
H200	-	✓	✓
K200	✓	✓	✓

Special specifications (different voltages, with casters, etc.)

- * * * (3 numerical digits), C * * * (3 numerical digits), etc.
Please consult us separately about special specifications.

Specifications

Oil cooling unit horsepower (HP)		1.2				2.0				
		AKC359				AKC569				
Model name		Standard	-C (CE compliant type)	-H (With heater)	-200 (With pump)	Standard	-C (CE compliant type)	-H (With heater)	-200 (With pump)	
Cooling capacity (50/60 Hz) ^{*1}	kW	3.5/3.5			3.2/3.2		5.6/5.6			
Heater	kW	-			-		2			
Supply power ^{*2}		Three-phase 200/200*220 VAC 50/60 Hz								
Power voltage	Main circuit	Three-phase 200/200*220 VAC 50/60 Hz								
	Operation circuit	DC12/24 V								
Maximum power consumption	When cooling	200 V 50 Hz	1.17 kW/4.2 A		1.44 kW/5.3 A		1.78 kW/6.2 A		2.10 kW/7.4 A	
		200 V 60 Hz	1.22 kW/4.3 A		1.60 kW/5.5 A		1.87 kW/6.3 A		2.30 kW/7.6 A	
		220 V 60 Hz	1.21 kW/4.1 A		1.60 kW/5.2 A		1.86 kW/6.1 A		2.30 kW/7.3 A	
Maximum current consumption	When heating	200 V 50 Hz	-	1.19 kW/3.5 A		-	-	2.34 kW/7.0 A		-
		200 V 60 Hz	-	1.19 kW/3.5 A		-	-	2.34 kW/7.0 A		-
		220 V 60 Hz	-	1.43 kW/3.9 A		-	-	2.81 kW/7.6 A		-
Exterior color		Ivory white								
External dimensions (H × W × D)	mm	995 × 450 × 560				1,200 × 470 × 670				
Compressor (Hermetic DC swing type)		Equivalent to 0.75 kW				Equivalent to 1.5 kW				
Evaporator						Shell-end coil type				
Condenser						Cross-fin-coil type				
Propeller fan	Motor	54 W				100 W				
Pump	Motor	-		0.4 kW-2P		-		0.4 kW-2P		
	Total head (standard point, 50/60 Hz)	-		10/15 m		-		10/15 m		
	Suction lift	-		0.5 m ³		-		0.5 m ³		
Temperature control (Selectable)	Synchronization type	Standard	Room temperature or machine temperature ^{*4} (Set to "Room temperature: Mode 3" by default)							
		Object to be controlled	Fluid inlet temperature or fluid outlet temperature (Set to fluid inlet temperature by default)							
	Fixed type	Synchronization range K	-9.9 to 9.9 against the reference temperature (Set at 0.0 by default)							
		Object to be controlled	Fluid inlet temperature or fluid outlet temperature							
		Range °C	5 to 50							
Fluid temperature controller resolution		±0.1°C								
Capacity control range		0 to 100%								
Timer function		ON timer: 1 to 999 hours (1-hour unit setting)								
Refrigerant control		Compressor revolutions by inverter + Opening of electric expansion valve								
Refrigerant (R410A) ^{*5} Filling amount	kg	0.80				1.25				
Protection devices/protective functions		A set of overcurrent relay (for a pump motor), discharge pipe temperature thermostat, condenser temperature thermostat, reverse-phase protection device, restart prevention timer, low room temperature protection thermostat, high fluid temperature protection thermostat, low fluid temperature protection thermostat, refrigerant leakage detector, evaporator clogging detection (intake pipe temperature thermostat), inverter protection device, circuit breaker, temperature fuse (-H type only), overheat prevention temperature switch (-H type only), high pressure switch (-C type only), and compressor thermal protector (-C type only)								
Operation range	Room temperature	°C		5 to 45						
	Fluid inlet temperature	°C		5 to 50						
	Fluid viscosity	mm ² /s		200 maximum (water soluble to ISO VG32)						
	Withstanding pressure	MPa		0.2						
	Rated circulating volume	L/min		35						
	Circulating volume	L/min		15 minimum						
Usable fluids ^{*6}		Lubrication oil, hydraulic oil, cutting oil, (water soluble) coolant, (grinding oil ^{*8}) (Use clean fluid that can pass through filter equipment with a 40-mesh or finer screen.)								
Connecting tube	Fluid inlet					Rc3/4				
	Fluid outlet					Rc3/4				
	Fluid drain port					Rc1				
	Priming port ^{*7}					Rc1/2				
	Oil pan drain	-			Rc3/8		-		Rc1/2	
Noise level ^{*8} (Value measured at 1m high in front, value equivalent as measured in anechoic chamber)	dB (A)	62				65				
Permissible transport vibration		Up and down vibration 14.7 m/S ² × 2.5 hr (7.5 to 100 Hz sweep/5 min.)								
Ingress protection ^{*9}		IP2X								
Mass	kg	83		86		105		106		
Molded-case circuit breaker (Rated current)	A	10		105		100		15		
Items prepared by the customer		Circulating pump				-				
						Circulating pump				

Note: ^{*1}. The cooling capacity indicates the value at the standard point (fluid inlet temperature: 35°C, room temperature: 35°C, fluid used: ISO VG32, flow rate: rated circulating volume). This unit has about ±5% of product tolerance.
^{*2}. Use a commercial power supply for the power source. The use of an inverter power supply may cause burn damage to the unit. The voltage fluctuation range should be within ±10%. If it is more than ±10%, please consult us.
^{*3}. Indicates the maximum value with clean fresh water.
^{*4}. The optional thermistor for machine temperature synchronization is required.
^{*5}. The SDS (Safety Data Sheet) of refrigerant R410A is attached to the -C type.
^{*6}. If the unit is used for a grinding machine or similar equipment, the evaporator tends to become clogged with foreign material, necessitating frequent maintenance of the evaporator or leading to significantly shorter pump service life due to wear of the pump parts (mainly the mechanical seals). This unit is cannot be used for water, chemicals, foods or fuels.
^{*7}. Not applicable to models without a pump
^{*8}. The rotational speed of the fan varies depending on the room temperature to conserve energy. Therefore, it is normal for its operating sound to vary accordingly.
^{*9}. Ingress protection for switch box: equivalent to IP54 (When wired with IP54 or higher conduit tube or other protection on the wiring port.)

AKC359

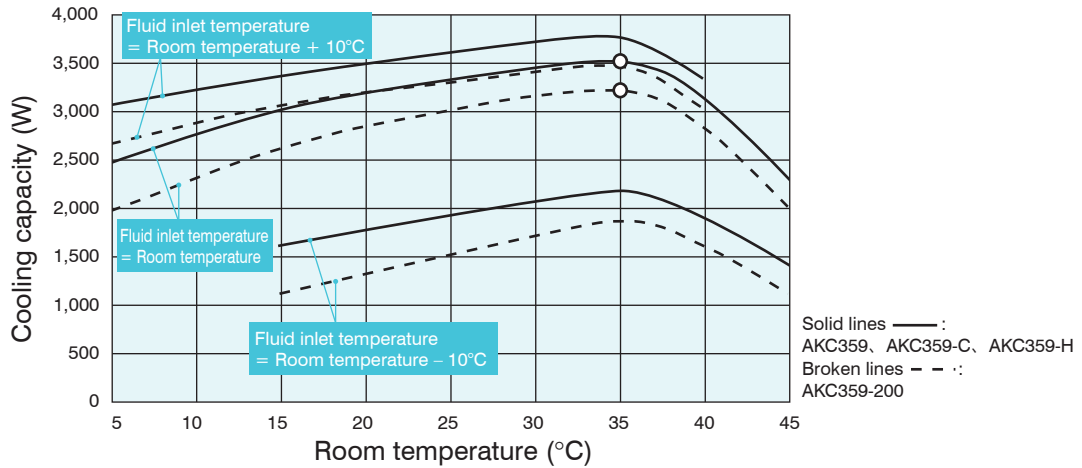

1. The O symbols indicate standard points. (Room temperature: 35°C, inlet fluid temperature: 35°C, flow rate: 35 L/min., fluid used: ISO VG32)
2. The cooling capacity varies depending on the room temperature, fluid temperature, the kinematic viscosity of the fluid, etc.

AKC569

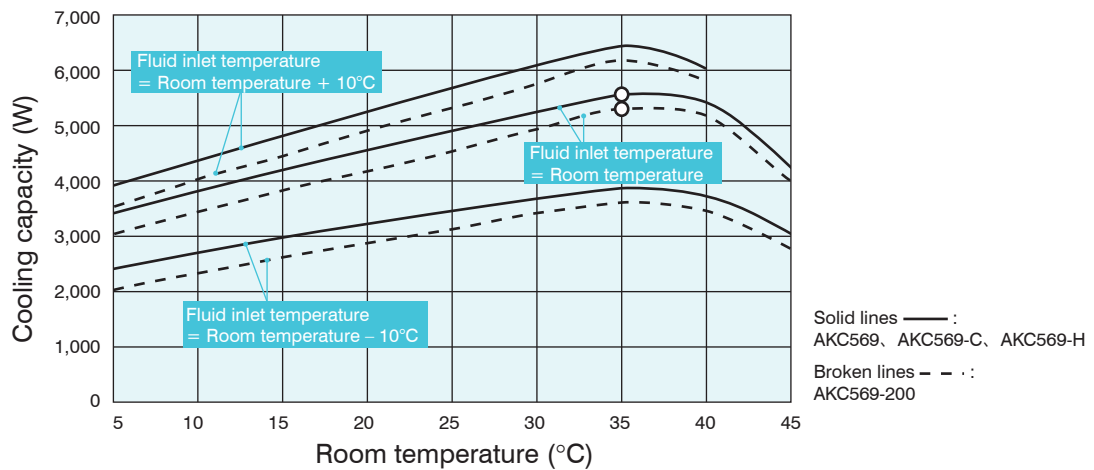

1. The O symbols indicate standard points. (Room temperature: 35°C, inlet fluid temperature: 35°C, flow rate: 35 L/min., fluid used: ISO VG32)
2. The cooling capacity varies depending on the room temperature, fluid temperature, the kinematic viscosity of the fluid, etc.

Internal Pressure Loss

For the selection of the oil pump size and piping system, such as diameter and length of pipes, refer to the chart below. Pay attention to making the oil flow rate 15 L/min or greater.

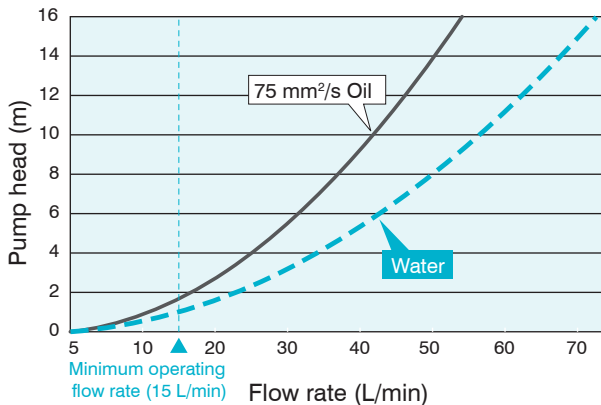

Flow Rate Characteristics for Models With a Pump

(Internal pressure loss included)

The chart below shows the flow rate characteristics of the pumps with the internal pressure loss taken into account. Select the diameters and lengths of pipes by referring to the chart below so that a circulating volume of 15 L/min or greater can be maintained.

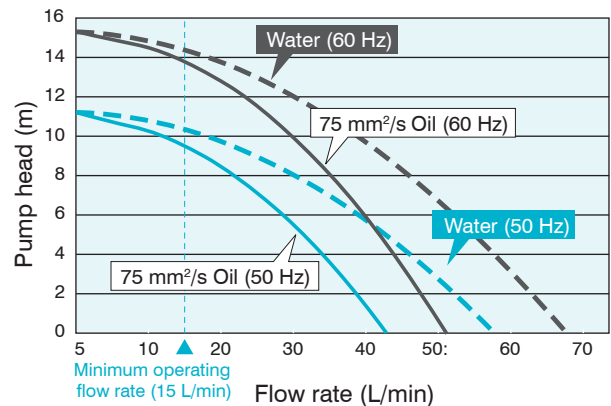

External Dimension Diagram



Note: Refer to Page 5 for more details.

• For the machining dimensions of the holes for installation on the tank, refer to page 12.

AKC359 (-C) (-H) (-200)

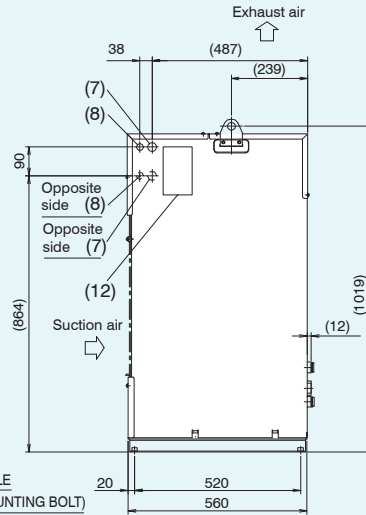
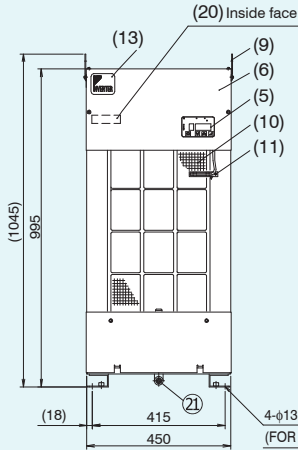
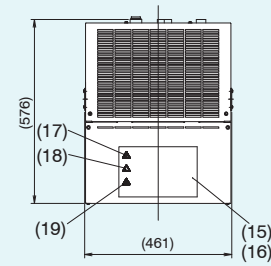

Part No.	Name	Description
1	Fluid inlet	Rc3/4
2	Fluid outlet	Rc3/4
3	Fluid drain port	Rc1 Plugged
4	PRIMING*	Rc1/2 Plugged
5	Control panel	
6	Electrical component box lid	
7	Power supply inlet (Right / Left)	φ28 Hole
8	Signal line inlet (Right / Left)	φ22 Hole
9	Eye plate	φ25 Hole
10	Air filter	

*Models other than those with a pump cannot be used.

Part No.	Name	Description
11	Room temperature thermistor	
12	Machine nameplate	
13	Design nameplate	
14	Instruction nameplate	
15	Overall caution plate	
16	Electric schematic diagram nameplate	
17	Battery charge mark nameplate	
18	Cutting injury caution nameplate	
19	High temperature caution nameplate	
20	Model name nameplate	
21	Oil pan drain*	Rc3/8 with PLUG Models with a pump only

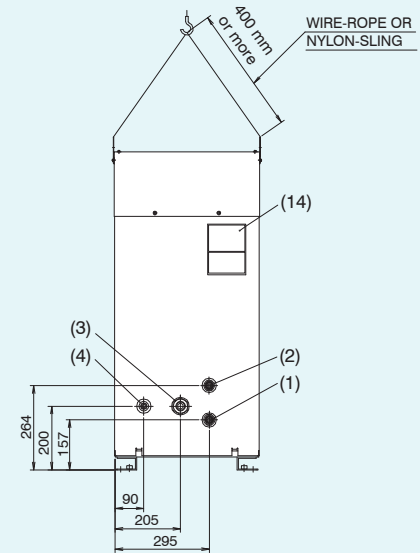

AKC569 (-C) (-H) (-200)

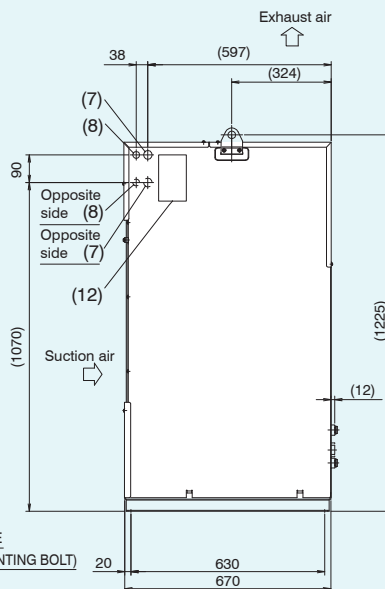
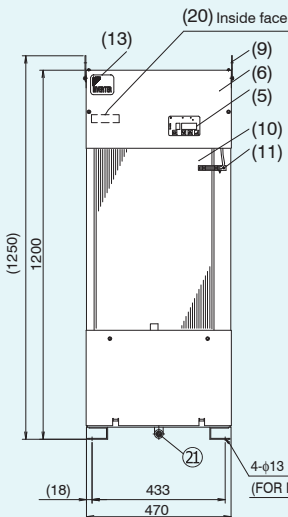
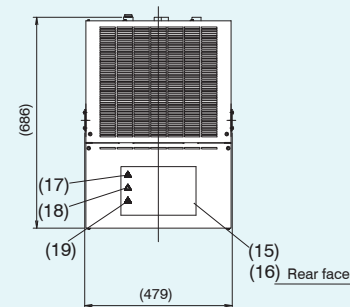

Part No.	Name	Description
1	Fluid inlet	Rc3/4
2	Fluid outlet	Rc3/4
3	Fluid drain port	Rc1 Plugged
4	PRIMING*	Rc1/2 with PLUG
5	Control panel	
6	Electrical component box lid	
7	Power supply inlet (Right / Left)	φ28 Hole
8	Signal line inlet (Right / Left)	φ22 Hole
9	Eye plate	φ25 Hole
10	Air filter	

*Models other than those with a pump cannot be used.

Part No.	Name	Description
11	Room temperature thermistor	
12	Machine nameplate	
13	Design nameplate	
14	Instruction nameplate	
15	Overall caution plate	
16	Electric schematic diagram nameplate	
17	Battery charge mark nameplate	
18	Cutting injury caution nameplate	
19	High temperature caution nameplate	
20	Model name nameplate	
21	Oil pan drain*	Rc1/2 with PLUG Models with a pump only

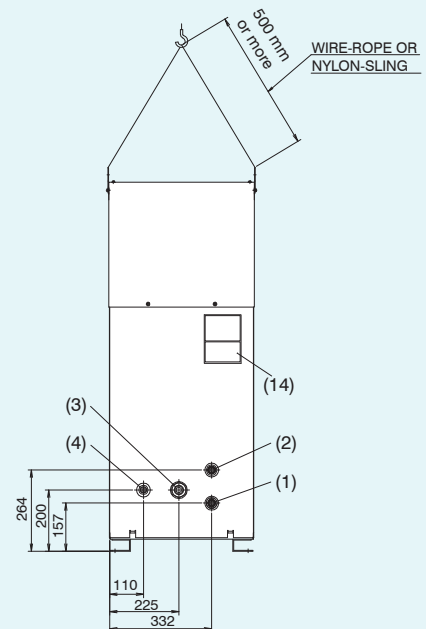

Thermistor (Compatible with all types of Oil Cooling Unit 9 series)

■ Thermistor models and applications

When this optional part is installed in the main machine or oil piping, the thermistor detects the temperature to allow the control of oil temperature.

Name	Model	Length of lead wire L (m)	Figure	Application (To be installed by you)	Applicable model
Thermistor for machine body synchronization	AKZ 9-OP-K5	5 m		For machine temperature synchronization control (implanted in the main machine)	AKJ9 Series, AKC9 Series
	AKZ 9-OP-K10	10 m			
	AKZ 9-OP-K15	15 m			
	AKZ 9-OP-A5	5 m			
AKZ 9-OP-A10	10 m				

Thermistor characteristics: Resistance value ... R25 (Resistance value at 25°C) = 20 kΩ, Tolerance: ±3%

■ Instruction for installation and connection

For AKZ 9-OP-K

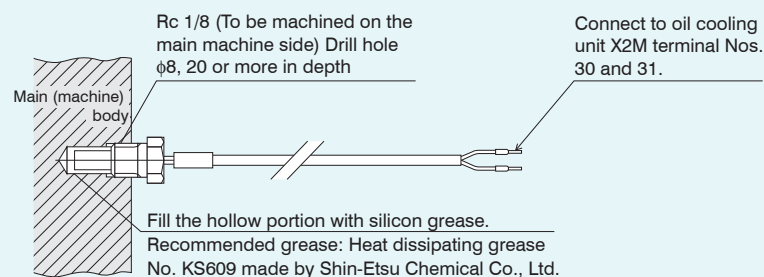

For AKZ 9-OP-A

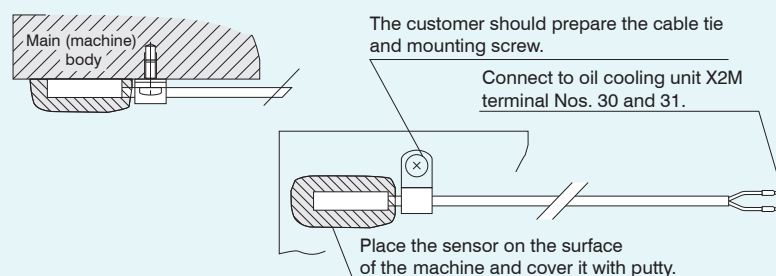

Thermistor (Compatible with all types of Oil Cooling Unit 9 series)

■ Installation positions of the thermistors for machine temperature synchronization.

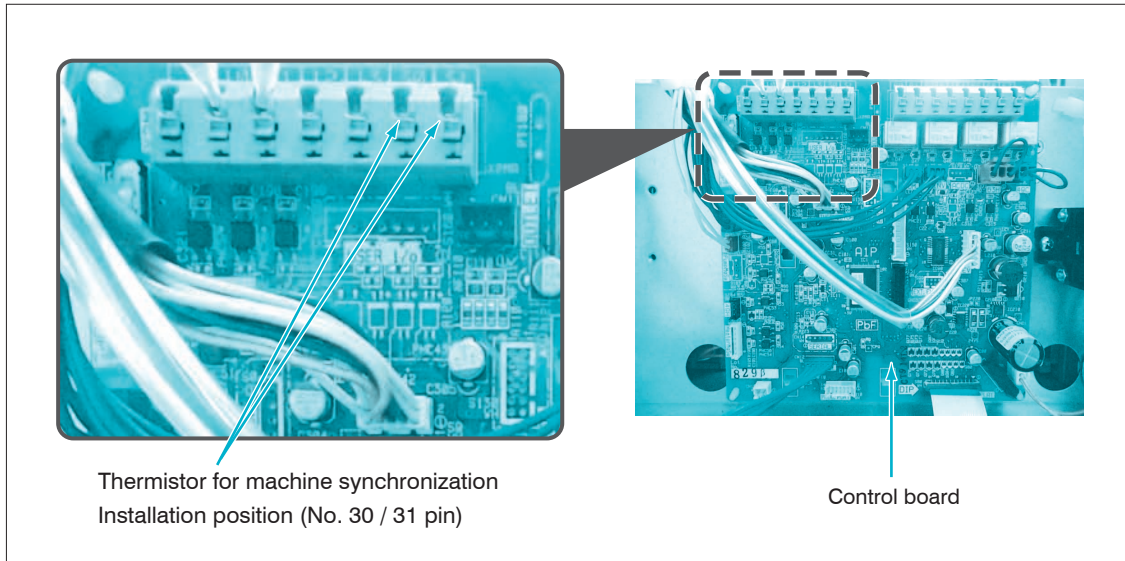

Extension board for main machine communication

The following functions are enabled by mounting this option board on the Oil Cooling Unit and connecting it to the main machine:

1. The operation mode and the operation setting can be changed from the main machine.
2. The alarm code and temperature data (machine temperature, room temperature, tank fluid temperature, inverter frequency) of the Oil Cooling Unit can be read from the main machine.

Communication method	Model	Installation position	Applicable model	Specification sheet No.
Serial communication only	AKZ9-OP-CS	Installation plate inside control box	AKJ189, AKJ359, AKJ459, AKJ569, AKJ909, AKJ1509, AKC359, AKC569	PSP04664

Note: 1. Refer to the specification sheet for the communication procedure and specifications.

■ Installation position for AKZ9-OP-CS (serial communication only)

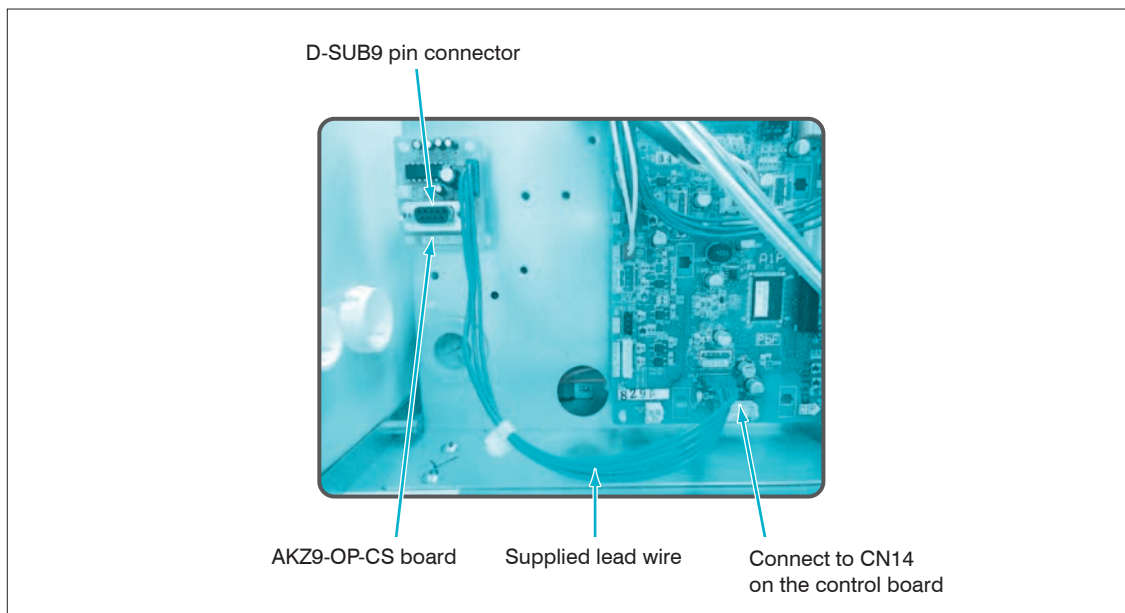

- Dimensions of communication board (W × H): 40 × 50
- The communication board is secured at four positions by locking support.

Part Names, Functions and Operation of Control Panel

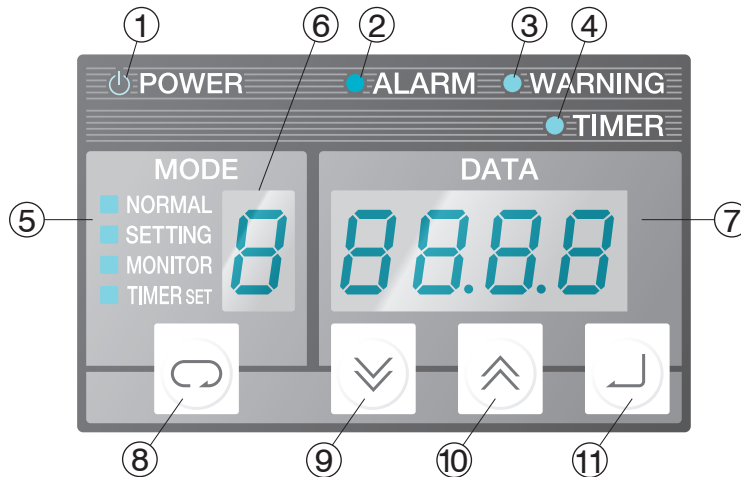

NO.	Item	Description
①	Power lamp (Green)	The lamp is continuously on while power is supplied.
②	Error warning lamp (Red)	When an error occurs Level 1 alarm: The lamp keeps blinking. Level 2 alarm: The lamp is turned on
③	Warning lamp (Green)	When a warning occurs Level 1 warning: The lamp keeps blinking. Level 2 warning: The lamp is turned on.
④	Timer mode lamp (Red)	The lamp keeps blinking while the machine is at a stop in the timer mode.
⑤	Operation mode display	Displays the mode of the control panel. NORMAL: Normal mode MONITOR: Monitor mode SETTING: Operation setting mode TIMER: Timer setting mode
⑥	Operation mode / Data No. display	Displays the current operation mode (normal mode /operation setting mode) or data number of the data currently displayed on the data display.
⑦	Data display	Displays various data. The data displayed differs depending on the operation mode and data number.
⑧	[SELECT] Select key	Selects the operation mode.
⑨	[DOWN] key	Decrements the value of the operation mode, data number or data by 1. When held for two seconds or longer, decrements the values by 10.
⑩	[UP] key	Increments the value of the operation mode, data number or data by 1. When held for two seconds or longer, increments the values by 10.
⑪	[ENT] (Confirm) key	Determines the operation mode, data number, and data to be changed.

■ Operation for change to each mode

A mode can be changed by operating the [SELECT] key in general.

To enter a special mode, hold down a number of keys in combination for more than five seconds.

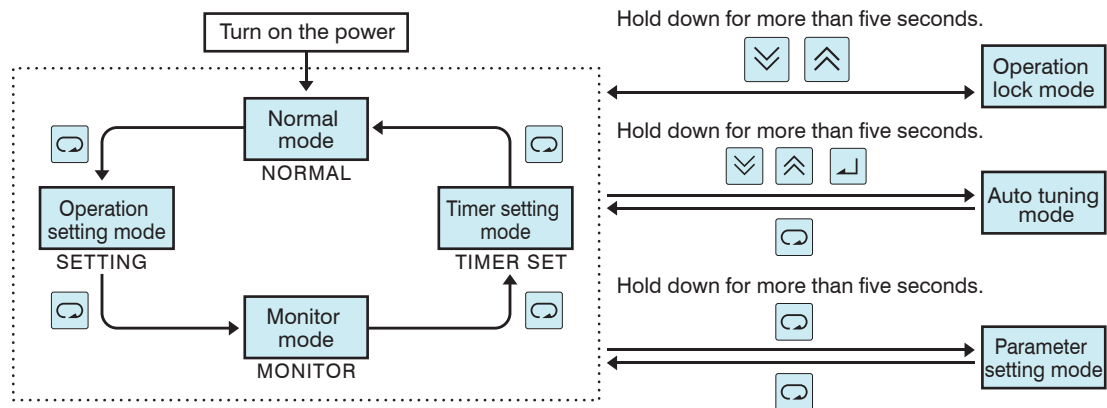

CAUTION

- The default setting is "operation lock mode". To start operation, perform the unlocking operation as shown above.
- The default settings for a standard machine are:

Operation mode: 3	(AKJ9 SERIES: Tank liquid temperature, room temperature synchronization control
		AKC9 SERIES: Room temperature synchronization, inlet fluid temperature control

Temperature difference: 0.0 (K)

Operation Mode and Setting Method

AKJ9 Series

Operation Mode No.	Mode name	Description	Setting temperature range	Necessary optional part
0	Tank fluid temperature, fixed temperature control	Maintains the tank fluid at a fixed temperature	5 to 50°C	
3	Tank fluid temperature, room temperature synchronization control	Synchronizes the tank fluid temperature with the room temperature	Room temperature -9.9 to +9.9 (K)	
4	Tank fluid temperature / machine temperature synchronization control	Synchronizes the tank fluid temperature with the machine temperature	Machine temperature -9.9 to +9.9 (K)	Machine synchronization thermistor

AKC9 Series

Operation Mode No.	Mode name	Description	Setting temperature range	Necessary optional part
0	Inlet fluid temperature, fixed temperature control	Maintains the inlet fluid at a fixed temperature	5 to 50°C	
1	Outlet fluid temperature, fixed temperature control	Maintains the outlet fluid at a fixed temperature	5 to 50°C	
3	Inlet fluid temperature, room temperature synchronization control	Synchronizes the inlet fluid temperature with the room temperature	Room temperature -9.9 to +9.9 (K)	
4	Inlet fluid temperature / machine temperature synchronization control	Synchronizes the inlet fluid temperature with the machine temperature	Machine temperature -9.9 to +9.9 (K)	Machine synchronization thermistor
5	Output fluid temperature / room temperature synchronization control	Synchronizes the outlet fluid temperature with the room temperature	Room temperature -9.9 to +9.9 (K)	
6	Outlet fluid temperature / machine temperature synchronization control	Synchronizes the outlet fluid temperature with the machine temperature	Machine temperature -9.9 to +9.9 (K)	Machine synchronization thermistor

Note: Refer to Page 17 for details of required optional parts.

■ Setting procedure

Default setting: Set to operation mode 3, and a temperature of “0.0” °C
When you use your machine at a setting other than the default setting, change the setting following the procedure shown below.

- Power ON Release the operation lock mode before starting operation for the first time.
(Hold down the and keys together for at least 5 seconds.)
- Select the “SETTING” operation setting mode (press the key once).

Changing the Operation Mode

3 Set the operation mode by pressing the or key.

4 Confirm by pressing the key.

Change the setting temperature

5 Set the temperature by pressing the or key.

6 Confirm by pressing .

- Return to the “NORMAL” mode by pressing the key three times.

Checking Data in the Monitor Mode

The following data can be checked in the monitor mode.

Monitor No.	Description		Note	Monitor No.	Description		Note
	AKJ9	AKC9			AKJ9	AKC9	
0	Machine body temperature [Th1]		*1	5	-	ΔT [Th4 - Th2]	*1
1	-	Outlet fluid temperature [Th2]	*1	6	Cooling capacity control command value (%)		-
2	Room temperature [Th3]		*1	7	Compressor inverter rotational speed (rps)		-
3	Tank fluid temperature [Th4]	Inlet fluid temperature [Th4]	*1	8	Power consumption (kW)		*3
4	Intake gas temperature [Th5]		*1	9	Extended DIN (hundreds digit), DOUT (tens digit) status		*2

*1. If the thermistor is not connected or has a broken wire, -99.9 is displayed.

*2. With the default setting, 0 is displayed. Note that display is enabled when parameter n020 is “1” or the optional communication extension board is installed.

*3. This is the roughly calculated value with a power supply voltage of 200 V (the error is approximately 20%).

Electric Schematic Diagram (Representative Model of AKJ9 Series)

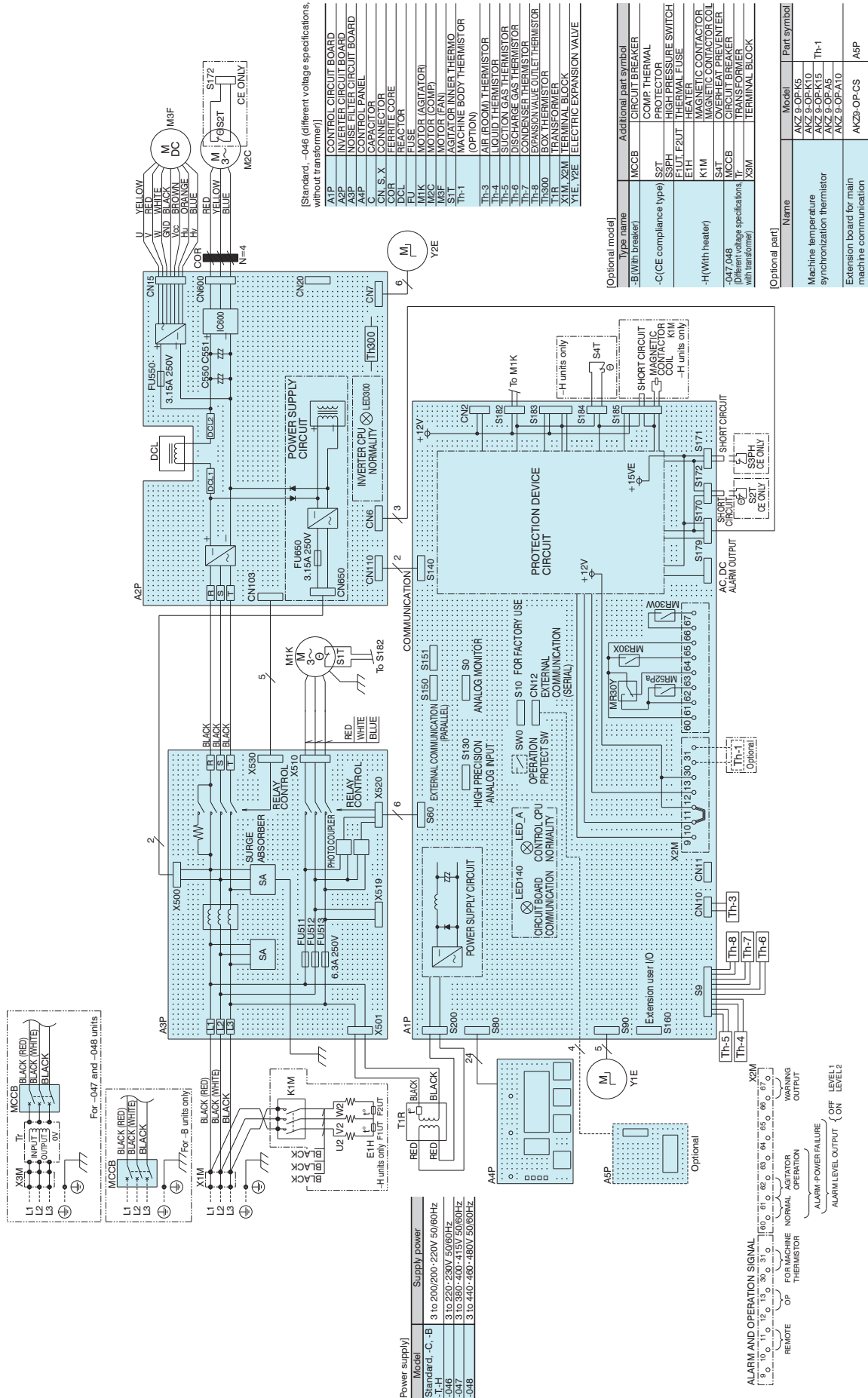

Electric Schematic Diagram (Representative Model of AKC9 Series)

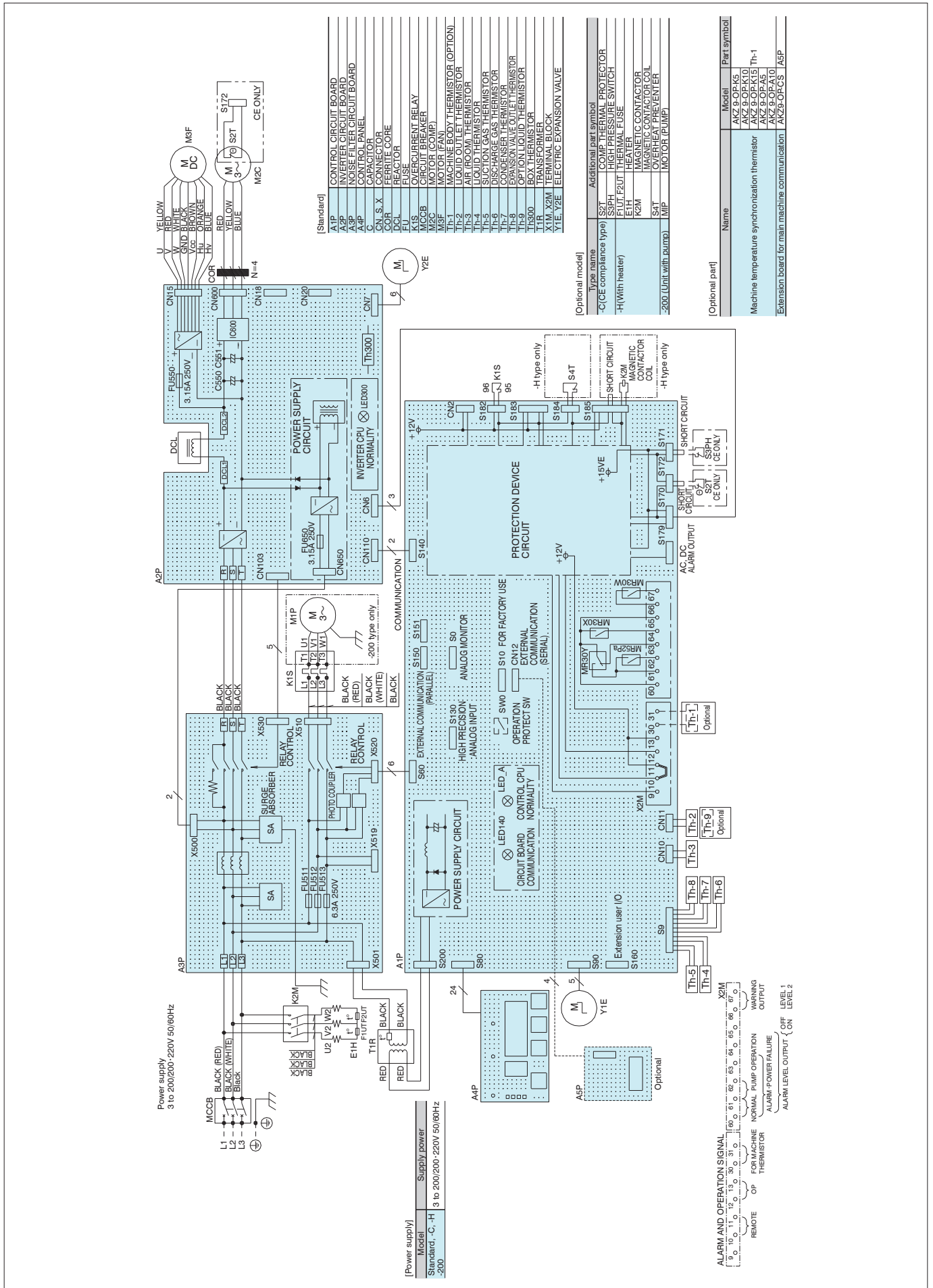

Electric Wiring Connection Instruction Diagram

1 Power supply capacity ... Power supply capacity ... Refer to the maximum power consumption/maximum current consumption panel of the specifications list (Pages 5, 6 and 14).

2 Connection to power supply terminal block (X1M, Tr)

- (1) AKJ××9: With the standard and optional (-C, -H, -046) types:
 - Connect to X1M.
- (2) AKJ××9: With the “with breaker” (-B) specifications:
 - AKC××9: All models:
 - Connect to the breaker.
- (3) AKJ××9: With different voltage types (with transformer: -047, -048):
 - Connect to the terminal block supplied with the transformer.

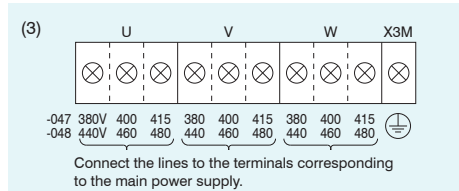
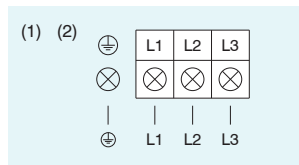

1. Screw terminal and wiring diameter

Series	Terminal block	Screw terminal	Wiring diameter		
			JIS cable	IEC cable	UL cable
AKJ 189, 359, 459, 569 AKC 359, 569	X1M	M4	2.0 mm ²	2.5 mm ² or more	AWG#14 or more
	Breaker	M5			
AKJ 909,1509	X1M	M5	3.5 mm ² or more	4.0 mm ² or more	AWG#12 or more
	Breaker	M5			

- 2. Use a round crimp-style terminal for connection.
- 3. The terminal block is for three poles and the ground wire is to be secured on the enclosure with a screw.

3 Connection to signal terminal block (X2M)

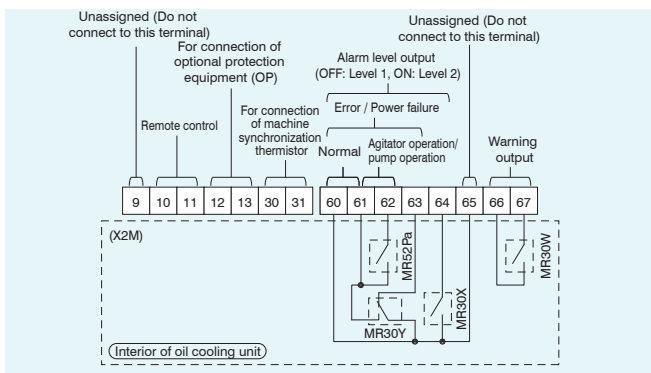

1. Straight crimp terminal and wiring diameter

Straight pin terminals	Wiring diameter		
	JIS cable	IEC cable	UL cable
*	0.25 mm ² to 1.25 mm ²	0.3 mm ² to 1.5 mm ²	AWG#22 to #16

- 2. Use a straight crimp-style terminal for connection.
 - 3. Use stranded wires for electric connection.
 - 4. The wiring size is 0.5 mm² to 1.5 mm² in the case of duplex cable according to IEC. If using stripped wires, make the stripped length 9 to 10 mm.
- * Recommended models and manufacturers: TGN TC-1.25-9T (NICHIFU Co., Ltd.)
APA-1.25N (Daido Solderless Terminal)

4 Signal output time chart

(1) Alarm/operation status output chart

Operation status			Remote operation (between [10] and [11])							
			ON				OFF			
Signal output			Normal	Level 1 error or Lock	Level 2 error	Power failure (Power OFF)	Normal	Level 1 error or Lock	Level 2 error	Power failure (Power OFF)
Normal (“a” contact)	60 - 61	ON OFF								
Error / Stop (Power OFF) (“b” contact)	60 - 63	ON OFF								
Error level (“a” contact)	60 - 64	ON OFF								
Agitator operation (NO contact)	61 - 62	ON OFF								

(2) Warning output chart

Operation status			Non-warning status				Warning status			
			Normal	Level 1 error or Lock	Level 2 error	Power failure (Power OFF)	Normal	Level 1 error or Lock	Level 2 error	Power failure (Power OFF)
Warning output (NO contact)	66 - 67	ON OFF								

- CAUTION** 1. The following electric wires can be used on the terminal block for straight crimp-style terminals.
 - Single wire: $\phi 0.57$ to $\phi 1.44$ (AWG#22~#16)
 - Stranded wire: 0.25 mm² to 1.25 mm² (AWG#22~#16)
- 2. Load applicable to [60 - 64] and [66 - 67] is as follows:
 - Min. applicable load: 10mV DC, 10 μ A or more
 - Max. applicable load: 30 V DC, 2 A (Resistance load)
- 3. For [10] to [13], please prepare contacts to meet the condition of minimum applicable load 12 V DC and 5 mA.
- 4. When the length of the thermistor to be connected to [30] - [31] is longer than 10m, or the wiring is routed in a poor noise environment, use shielded wire.

Notes for Handling

• Important notes to be observed regarding the main machine side (machine tools and industrial machinery)

- When rough transport conditions are expected while transporting the machine overseas or elsewhere, special precautions should be taken in the packaging and transportation method so as to avoid the application of excessive force on the oil cooling unit (this unit).
- Oil Cooling Unit (this machine) does not incorporate a flow switch for checking the oil supply and a temperature switch for abnormal supply of oil temperature (high temperature or low temperature). So, please provide a protection device such as a flow.

Notes for operation and cooling capacity

- Do not use the oil cooling unit to cool a fluid from 50°C or higher. Start to operate the oil cooling unit at the same time as the main machine or before the fluid temperature rises to 40°C.
- Do not place an object that hinders ventilation within 500 mm of the air-intake or exhaust.
- If the air filter is clogged, the cooling capacity is reduced. Clean the air filter (wash with hot water or clean with air) periodically once every two weeks to prevent clogging.
- If cutting chips and powder-like chips deposit on and adhere to the cooling coil (evaporator) in the AKJ9 series, the cooling capacity should be diminished and it could cause failure. To avoid the adherence of deposits on the cooling coil, install an efficient return filter on the return side (fluid inlet) of the tank and periodically clean the tank inside.

Notes regarding fluid usable with Oil Cooling Unit

- The fluid usable with the oil cooling unit is listed in the table below for each series. (✓ symbol ... Can be used, “Unusable” symbol ... Cannot be used)
- Do not use fluid listed below as “unusable”



	Description	AKJ 9 Series	AKC 9 Series
Lubrication oil Mineral hydraulic oil	<ul style="list-style-type: none"> Oil that is classified as third class petroleum or fourth class petroleum of the fourth group hazardous materials stipulated in the Fire Defense Law and that corresponds to discoloration No. 1 in the copper corrosion test method (JIS K2513) of petroleum products 	✓	✓
Nonflammable hydraulic oil <ul style="list-style-type: none"> Phosphate ester hydraulic fluid Chlorinated hydrocarbon series Water - Glycol series W/O - O/W emulsion series (High-aqueous hydraulic oil) 	—	Unusable	Unusable
Coolant fluid <ul style="list-style-type: none"> Water-soluble cutting and grinding fluid Non water-soluble cutting and grinding oil 	—	✓	✓
Ethylene glycol (Antifreeze liquid)	Fluid not including any ingredient that corrodes the SUS304 material used for the evaporator coil	✓	Unusable
Water (Industrial water)		✓	Unusable
Inflammable liquid like fuel	Liquid equivalent to special flammables, alcohol, first class petroleum and second class petroleum of the fourth group hazardous materials specified according to the Fire Defense Law	Unusable	Unusable
Drugs	—	Unusable	Unusable
Liquid for food products	Drinking water, water for cooling food products, etc.	Unusable	Unusable

Notes for Handling









* Before operating the product, be sure to read and understand the operation manual supplied with it.

● Instructions for safe operation





(Signs and Instructions)

	DANGER	Failure to observe the instruction may cause an imminent hazardous situation that may result in death or serious injury.
	WARNING	Failure to observe the instruction may result in death or serious injury.
	CAUTION	Failure to observe the instruction may result in personal injury or damage to property.



① General instructions

- [ DANGER] ① Use the product only in accordance with the intended specifications (specified in brochure, specification sheet, operation manual, and caution plates).
- [ DANGER] ② Never operate the equipment in an explosive atmosphere
- [ DANGER] ③ Do not disassemble, repair or modify the equipment by yourself.
- [ DANGER] ④ Always comply with the laws and regulations for safety (Industrial Safety and Health Law, Fire Defense Law, and JIS B 8361 Guidelines of Hydraulic System).
- [ WARNING] ⑤ Caution in the event of refrigerant leak
 - Ventilate the room adequately (to avoid the risk of suffocation).
 - Avoid direct contact of the refrigerant with skin (to avoid the risk of cryogenic burns).
 - In the event of inhalation of a great deal of refrigerant, contact with skin, or refrigerant in the eye, seek medical attention immediately.
- [ WARNING] ⑥ In the event of an abnormal condition, stop operation promptly, investigate the cause of the problem and take appropriate remedial measures.
- [ CAUTION] ⑦ Do not use the unit in atypical environments (locations subject to high temperatures, high humidity, or a lot of dust, contamination, steam, oil mist or corrosive gases: H₂S, SO₂, NO₂ or Cl₂).
- [ CAUTION] ⑧ Install a flow switch and temperature switch on the main machine to protect the main shaft and others.
- [ CAUTION] ⑨ Do not get on the equipment or place an object on the equipment.







② Instructions for transportation

- [ DANGER] ① When hoisting the equipment, check its weight and use the eye plates and hangers on the equipment properly.
- [ WARNING] ② Do not get approach the equipment while it is being hoisted and moved.
- [ CAUTION] ③ When moving the equipment, take appropriate measures for fall prevention.
- [ CAUTION] ④ Do not tilt the equipment 30 degrees or more while transporting the equipment (including during storage).





③ Instructions for installation

- [ WARNING] ① Install the equipment on a rigid, level foundation and secure it appropriately.
- [ CAUTION] ② Do not place an object near the suction port and discharge port of the equipment.



④ Instructions for wiring and piping installation

- [ DANGER] ① Wiring and piping installation should be performed by a person with specialized knowledge and skills.
- [ DANGER] ② Always use a commercial power supply for the power source. (The use of an inverter power supply may cause burn damage).
- [ DANGER] ③ Connect the wiring for power supply in accordance with the electric wiring instruction diagram of the specification sheet and operation manual.
- [ DANGER] ④ Ground the equipment properly.
- [ WARNING] ⑤ Install the wiring in accordance with the standard by checking the electric schematic diagram.
- [ CAUTION] ⑥ Always install a dedicated breaker (all-pole (3-pole) molded case circuit breaker) appropriate for the capacity of the Oil Cooling Unit on the main power supply on site.
- [ CAUTION] ⑦ Check that piping for coolant has a pressure resistance of at least 1 MPa and make proper connections. (For AKC)







⑤ Instructions for trial run

- [ CAUTION] ① Check to see that the main machine is in a safe status (not activated) before starting the trial run.
- [ CAUTION] ② Check to see that the fluid piping and electric wiring are correctly connected to the main machine and that there is no looseness in connections and joints.
- [ CAUTION] ③ Disable the operation lock of the equipment (Oil Cooling Unit) before starting the main machine.
- [ CAUTION] ④ Check that the tank contains the correct volume of the fluid used. (For AKJ)
- [ CAUTION] ⑤ Check that the fluid piping system contains the required amount of fluid, and that the piping is not blocked part way through. (For AKC)

⑥ Instructions during operation

- [ DANGER] ① Do not splash water or fluid on the equipment.
- [ WARNING] ② Do not push your finger or an object into gaps of the equipment.
- [ CAUTION] ③ Do not touch the heated exhaust port of the equipment.

⑦ Instructions for maintenance and inspection

- [ DANGER] ① Perform maintenance and inspection with the equipment kept open. Working in a closed status may result in suffocation due to the leak of refrigerant.
- [ DANGER] ② Always turn off the main power supply before starting maintenance and inspection.
- [ DANGER] ③ Wait for five minutes after turning off the main power supply and start maintenance and inspection operation.
- [ DANGER] ④ Do not operate the equipment with the cover of the equipment opened.
- [ CAUTION] ⑤ Wear protective gear such as gloves and an eye protector when performing maintenance, inspection and cleaning.
- [ CAUTION] ⑥ Clean the air filter periodically (once every two weeks in general).
- [ CAUTION] ⑦ Clean the cooling coil periodically to ensure that there is no accumulation/adhesion of chips, etc. (For AKJ)

Method of Selection of Oil Cooling Unit

In the case of cooling of cutting and grinding fluid

1. The amount of heat generation from the cutting and grinding fluid system should be roughly estimated according to the following formula as the tank capacity and pump flow rate are generally large. After rough estimation, the amount of heat generation should be determined by conducting tests on the actual machine to select the oil cooling unit.
2. Formula for rough calculation of amount of heat generation

$$Q = Q_1 + Q_2 + Q_3$$

- Q : Heat load of the entire machine tool system
- Q₁ : Amount of heat generated during machining on a machine tool
- Q₂ : Amount of heat generation of the pump motor for coolant pump (Amount of heat transferred to coolant)
 $Q_2 = \text{pump motor output (kW)} \times \frac{\eta}{100}$
- Q₃ : Heat balance of the coolant fluid passing through the coolant tank and the room temperature
 $Q_3 = K \cdot A \cdot \Delta T$ K : Rate of heat passage (W/m² · °C), generally K = 11.6 to 23.2
 A : Surface area of the tank in contact with the fluid (m²)
 ΔT : Room temperature – controlled temperature of fluid in tank (°C)

3. For testing, determine the amount of heat generation according to the method shown below.

General guide for heat generation

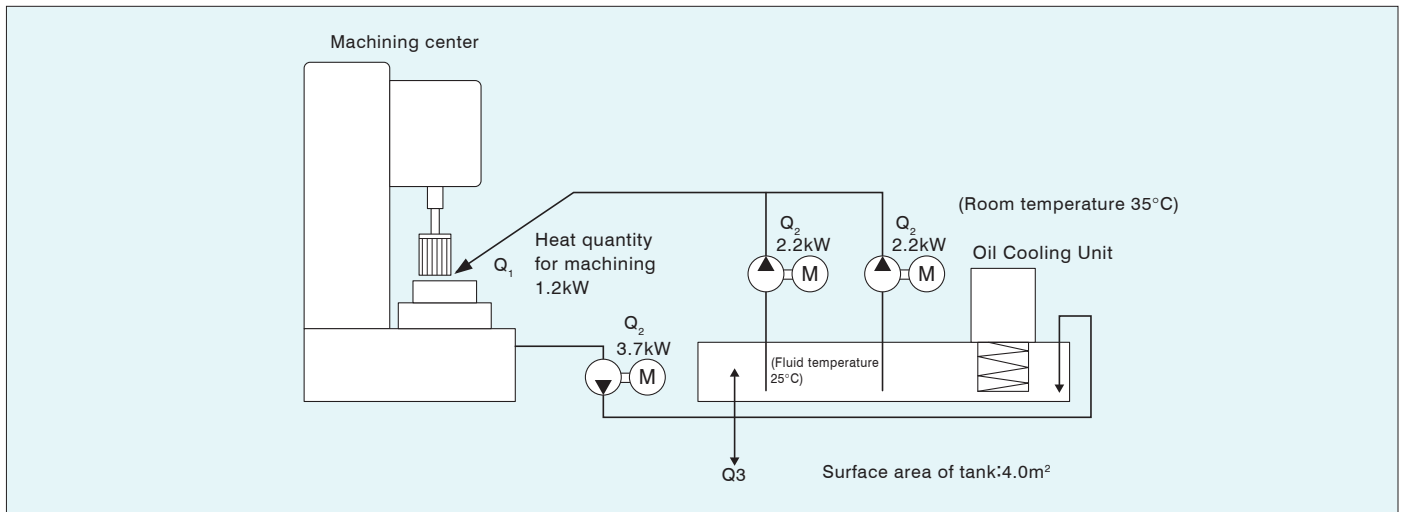

E.g.) In the diagram above,
 When Q₁ = 1.2 kW
 $Q_2 = (2.2 + 2.2 + 3.7) \times \frac{50}{100} \approx 4.1 \text{ kW}$ (For a coolant pump, “η” is generally 50%).
 $Q_3 = 20 \times 4 \times (35 - 25) / 1000 = 0.8 \text{ kW}$
 $\therefore Q = Q_1 + Q_2 + Q_3$
 $= 1.2 + 4.1 + 0.8$
 $= 6.1 \text{ kW}$

• Method: Estimating the amount of heat generation from the rate of increase of the fluid temperature in the tank

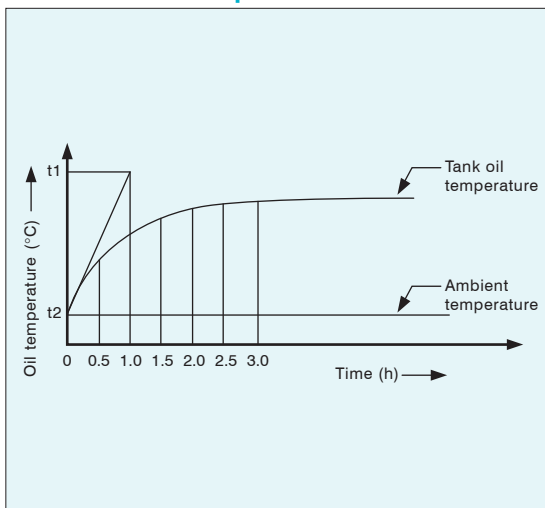

Find the maximum gradient of the fluid temperature rise.

(To do this, it is necessary to measure Δt every minute during the first 10 minutes.)

$$Q = 2.778 \times 10^{-7} Cp \cdot \gamma \cdot V \cdot \Delta t / H$$

- Q : Heat release value (kW)
- Cp : Constant pressure specific heat (J/kg°C) . . . 1967.4 J/kg°C
- γ : Weight volume ratio (kg/m³) . . . 876 kg/m³
- V : Total oil quantity (m³)
- Δt : Temperature difference (°C) ... t₁-t₂
- H : Time (h)

E.g.) When the total oil volume is 300 L (0.3 m³) and “Δt” is 10°C.

$$Q = 2.778 \times 10^{-7} \times 1967.4 \times 876 \times 0.3 \times 10$$

$$= 0.479 \times 0.3 \times 10 \approx 1.4 \text{ kW}$$

OIL
COOLING
UNIT

AKJ
AKC

9

SERIES

DAIKIN INDUSTRIES, LTD.

Oil Hydraulic Division

Osaka Office

YODOGAWA PLANT

1-1, Nishi-Hitotsuya, Settsu, Osaka 566-8585, Japan

Home Page: <http://www.daikinpmc.com/en/>

Overseas service network

Please contact Daikin Sales Counter for servicing of Oil Cooling Unit in countries outside Japan.

Daikin is ready to offer you service in conjunction with the sales agents of our Air-conditioning and Hydraulic Divisions located in seven countries and regions worldwide.

Country/Region	Locations	Company name
China	Shanghai	© DAIKIN HYDRAULICS (SUZHOU) CO., LTD. 上海分公司 (Shanghai Branch)
	Dalian	© DAIKIN HYDRAULICS (SUZHOU) CO., LTD. 大連分公司 (Dalian Branch)
	Beijing	© DAIKIN HYDRAULICS (SUZHOU) CO., LTD. 北京營業所 (Beijing Office)
	Guangzhou	© DAIKIN HYDRAULICS (SUZHOU) CO., LTD. 廣州營業所 (Guangzhou Office)
	Shenyang	© DAIKIN HYDRAULICS (SUZHOU) CO., LTD. 瀋陽營業所 (Shenyang Office)
Korea	Seoul	© KD HYDRAULICS, LTD.
Taiwan	Taipei	HO TAI DEVELOPMENT CO., LTD.
Singapore	Singapore	© ZICOM PRIVATE LTD.
Thailand	Bangkok	SIAM DAIKIN SALES CO., LTD.
India	New Delhi	DAIKIN AIR CONDITIONING INDIA PVT. LTD DELHI BRANCH
U.S.	Illinois	© ALL WORLD MACHINERY

© Sales agents of hydraulic equipment.

Others are the sales agent of air conditioning equipment.

(As of Oct. 30, 2015)