

Hybrid Hydraulic System
ECORICH
Design #40 Series

EHU1404

EHU2504

EHU2507

EHU3007

Instruction Manual

Draft

DAIKIN INDUSTRIES, LTD.

Oil Hydraulic Division

Introduction

Thank you for choosing a Daikin Hydraulic Unit "ECORICH". The "ECORICH" IPM motor drive hydraulic unit achieves further energy savings and superior functions by adopting both advanced hydraulic technology and an energy-saving IPM motor drive system that is a Daikin original development.

This instruction manual describes how to handle ECORICH, along with maintenance inspections, troubleshooting, and specifications. Refer to this manual thoroughly before using your ECORICH, and use it correctly.

General Precautions

- **Improper operation or handling of this product will cause accidents, reduced service life or performance deterioration of the equipment.**
- **Be sure to carefully refer to this manual and all accompanying documents before starting installation/running/maintenance inspections, and use the product correctly after having familiarized yourself with the information about the equipment, the safety information and all the cautions.**
- **The illustrations and photographs that appear in this manual may show the covers or safety guards removed in order to explain the details. When running this product, be sure to refit the covers and guards in their original positions as stipulated, and follow the instructions in this manual.**
- **The contents of this manual are subject to modification as appropriate for the sake of improving the product, changing specifications, or improving the users' convenience.**
- **For the latest version, please check our Oil Hydraulics Division's internet service (<http://www.daikinpmc.com/>).**
- **Take care to ensure that the contents of this manual are properly conveyed to the people who will use this product.**
- **When incorporating this product as a part of your machinery product, you are requested to insert the contents of this manual into the instruction manual for the machine.**
- **Be sure to keep this manual and the accompanying documents, delivery specifications and so on so that they can be referred to at any time.**
- **The figures given in this manual may not be same as the actual product due to product improvement.**
- **This manual is the literature relating to the safe handling of Daikin hydraulic units. Please also prepare literature for the safe handling of your own machines in accordance with the various regulations and standards, for safe running and maintenance.**

Chapter 1.	SAFETY INSTRUCTIONS	6
1.1	Indications of Safety Instructions in this Manual	6
1.2	Notes on Safety	6
1.2.1	Disclaimers	6
1.3	Restrictions on Applications.....	7
1.3.1	General Precautions.....	7
1.4	Precaution.....	8
1.5	For Safe Operation	9
1.5.1	Installation and wiring	9
1.5.2	Operation.....	10
1.5.3	Maintenance inspections.....	11
1.5.4	Disposal.....	11
Chapter 2.	FEATURES AND CONSTRUCTION	12
2.1	Energy Savings.....	12
2.2	Nomenclature.....	13
2.2.1	Models.....	13
2.2.2	Manufacturing number.....	14
Chapter 3.	PRODUCT SPECIFICATIONS AND CONDITIONS OF USE	15
3.1	Product Specifications	15
3.2	Conditions of Use.....	16
3.3	PQ Representative Characteristic Diagrams	17
3.4	External Dimensions	18
3.5	Hydraulic Circuit.....	19
Chapter 4.	COMPONENT PARTS AND PART NAMES	20
Chapter 5.	PROCEDURE FOR STARTING UP	21
Chapter 6.	CHECKS UPON RECEIVING THE PRODUCT	22
6.1	Check on the Contents of the Packaging.....	22
6.2	Check on the Model	22
Chapter 7.	TRANSPORTATION/INSTALLATION	23
7.1	Transportation.....	23
7.1.1	Transportation in the packaged state	23
7.1.2	Transportation of the product	23
7.2	Installation.....	24
7.2.1	Secure the space for air intake/exhaust.....	24
7.2.2	Securing the hydraulic unit	25
Chapter 8.	HYDRAULIC PIPING	26
8.1	Piping.....	26
8.2	Filling with Hydraulic Oil.....	27
Chapter 9.	ELECTRICAL WIRING	28
9.1	Procedure for Mounting Exterior Covers.....	29
9.2	Overall Wiring Diagram.....	31
9.3	Installation of the Breaker	31
9.4	Connection of the Main Power Supply.....	32

9.5	Connection of Input/Output Signal Cables.....	34
9.5.1	Digital inputs	36
9.5.2	Digital outputs	37
9.5.3	Contact outputs	38
Chapter 10.	TRIAL RUNNING	39
Chapter 11.	PANEL OPERATIONS	40
11.1	Names and Main Functions of Each Part of the Operation Panel	40
11.2	Functions of the Operation Panel	40
11.2.1	Function overview.....	40
11.2.2	Switching Among Modes.....	41
11.3	Regular Mode	41
11.4	Monitor Mode	42
11.4.1	List of display items in the monitor mode	42
11.4.2	Monitor mode operations.....	43
11.5	Setting Mode.....	44
11.5.1	Setting mode operations.....	44
11.6	Alarm Mode Display.....	46
11.6.1	Alarm mode operations	46
Chapter 12.	ADJUSTING PARAMETERS.....	48
12.1	Parameter List.....	48
12.2	[P00: DI_A] Switching the Effective Logic for the ON/OFF Signal	52
12.3	[P13: PL0/QL0] Pressure/Flow Rate Characteristics and Settings	52
12.4	Setting Output Signals	53
12.4.1	Parameters	53
12.4.2	[P39: DO_S] Digital output selection/[P47: RMOT] Alarm relay output maintenance notification enable/disable.....	53
12.5	Pressure Switch	54
12.5.1	Parameter list	54
12.5.2	Explanation of parameters.....	55
12.6	Settings Relating to Warnings/Alarms	56
12.6.1	Setting judgment criteria for [E64: Dry running error].....	56
12.6.2	Setting related to [E66: Temperature error due to pressure holding rotation speed drop]	56
12.6.3	Setting related to [L49: Motor electronic thermal relay overload warning]	56
12.7	Others	57
12.7.1	[P45: AC_F] Cooling fan motor speed.....	57
12.7.2	[P32: S_TM] Surge suppression at starts.....	57
12.7.3	[P48 : T_SP] Reverse rotation warning judgment wait time/[P49: SMTM] Start acceptance wait time.....	58
Chapter 13.	TROUBLESHOOTING.....	59
13.1	Alarm Causes and Corrective Actions	59
13.2	Warning Causes and Corrective Actions	64
13.3	Periodic Maintenance	66
13.4	Cleaning/Replacement Work	68
13.5	Oil Cooler Maintenance Instructions	69
13.5.1	Removing the oil cooler.....	69
13.5.2	Disassembling the oil cooler.....	70
13.5.3	Cleaning the core	70
13.5.4	Cleaning the DC fan	70

13.5.5 Reassembly.....	70
13.6 Oil Filler Port Cum Air Breather Maintenance Instructions.....	71
13.6.1 Removal method	71
13.6.2 Cleaning.....	71
13.6.3 Mounting.....	71
13.7 Suction Strainer Maintenance Instructions	72
13.7.1 Removal method	72
13.7.2 Cleaning.....	72
13.7.3 Reassembly.....	73
13.8 High-pressure Safety Valve Adjustment Instructions.....	73
13.9 Fixed Throttle (φ0.8) Mounting Instructions.....	75
13.10 Minimum Rotational Speed Adjustment Instructions.....	76
Chapter 14. Output Signal Timing Charts.....	77
14.1 Timing Chart at Powering Up.....	77
Chapter 15. ABOUT Hybrid-Win (MAINTENANCE/CONTROL FUNCTIONS)	79

Draft

Chapter 1. SAFETY INSTRUCTIONS

1.1 Indications of Safety Instructions in this Manual

In this manual, safety instructions are classified into three categories: “▲ DANGER”, “▲ WARNING” and “▲ CAUTION”.

- ▲ DANGER: Improper handling without regard to this indication will cause an imminently hazardous condition that may result in death or serious injury.
- ▲ WARNING: Improper handling without regard to this indication will cause a potentially hazardous condition that may result in death or serious injury.
- ▲ CAUTION: Improper handling without regard to this indication will cause a potentially hazardous condition that may result in moderate or slight injury, or property damage.

Note that even an item indicated as “▲ CAUTION” may result in a serious accident depending on the situation. Safety instructions given in this manual include important information regardless of their categories. Be sure to observe all of them.

1.2 Notes on Safety

1.2.1 Disclaimers

- Daikin shall not be responsible for any damage attributable to fire, earthquake, a third party's action or other accidents, or customers' intentional acts, misuse or use under abnormal conditions.
- Daikin shall not be responsible for any consequential damages (loss of business profits, business interruption) attributable to the use of this product, or the inability to use it.
- Daikin shall not be responsible for any accident or damage attributable to negligence in observing the instructions given in the instruction manual or delivery specifications.
- Daikin shall not be responsible for any damage attributable to malfunction, etc., resulting from the combination with connected equipment.
- Daikin shall not be responsible for any accident or damage attributable to disassembly, modification, etc., of the product by the customer.

1.3 Restrictions on Applications

▲ DANGER

- This product has not been designed or manufactured for the purpose of use in equipment used in situations where human lives are at stake, for life-support equipment for example, or its associated systems, or for special applications including mobile structures that carry people, medical uses and nuclear power uses.
- This product has been manufactured under strict quality control, but when it is used with equipment where its failure, for example, can be anticipated to result in a serious accident or loss, install safety devices in the machinery.

1.3.1 General Precautions

▲ DANGER

- Ensure that transportation, installation, piping, wiring, running, operation, maintenance and inspection work are carried out by people with the required expertise.
- When working, wear the safety gear required for safe work (working clothes, safety belt, helmet, safety shoes, gloves, etc.).
- This product has corners. When installing it, work with care to avoid injuries.
- Do not use this product outside the specifications stated in this manual, the catalog, the delivery specifications and elsewhere.
- Never modify the product. Also, never disassemble it except for the purposes of inspection as described in this manual. Otherwise, there is a risk of electric shock, fire, and injury.
- When this product fails, it stops running and cannot maintain the hydraulic pressure supplied. To ensure that machines and units do not enter a dangerous state when this product fails, install a safety device for the system as a whole, such as an emergency brake. Otherwise, there is a risk of accidents and injuries.
- Do not use this product in locations where there is direct contact with coolant, for example, or in an atmosphere that is corrosive to rubber. In addition, never use it in the vicinity of combustible material.
- Do not install or run this product while it is damaged or has missing parts. Otherwise, there is a risk of accidents.
- Do not use this product beyond the specifications stated in this manual. Otherwise, there is a risk of breakage, fire and injury.

▲ CAUTION

- Be sure to carry out daily inspections (as described in this manual or the accompanying documents).
- Do not apply any external force to this product, for example by climbing on it or striking it. Otherwise, there is a risk of injury and breakage.

1.4 Precaution

- (1) Regarding the hydraulic connections to this hydraulic unit, use hoses to prevent transmission of the vibration of the motor pump to the machine.
- (2) This hydraulic unit is equipped with a fan to cool the hydraulic oil, controller and motor. To assure the air intake and exhaust for the fan, do not place any obstruction within 10 cm from the unit. In addition, install the unit at a location with good ventilation so that hot air does not remain.
- (3) Turning the power ON/OFF frequently significantly shortens the life of the controller. Run and stop this hydraulic unit by using start/stop digital inputs. Leave an interval of at least 8 minutes between stopping and running of the unit by turning the power ON/OFF. When stopping and running of the unit with start/stop signals, leave an interval of at least 0.5 seconds between the stop command and restarting.
- (4) This hydraulic unit is equipped with a safety valve. The high-pressure safety valve is set at 1.5 MPa as factory default. Readjust the set pressure of the high-pressure safety valve according to your usage by following "13.8 High-pressure Safety Valve Adjustment Instructions".
Note also that the set pressure of the high-pressure safety valve may drop due to repeated protracted operation of the machine or contamination in the hydraulic oil. If the product is used continuously with the safety valve actuated, an alarm may occur due to temperature rise for example. In this case too, carry out readjustment.
- (5) Restrict continuous use at the maximum pressure to 5 L/min or less.

1.5 For Safe Operation

Be sure to carefully read this manual and all accompanying documents before starting installation/running/maintenance inspections, and use the product correctly after having familiarized yourself with the information about the equipment, the safety information and all the cautions.

1.5.1 Installation and wiring

▲ DANGER

- The wiring work must be done by a qualified electrical engineer. Otherwise, there is a risk of electric shock or fire.
- Personnel doing wiring work must wear gloves and long sleeves and implement safety measures to avoid injuries such as grazes.
- Personnel doing wiring work must wear gloves and long sleeves and implement safety measures to prevent electric shocks and fire due to static electricity.
- Complete the installation before starting the wiring work. Otherwise, there is a risk of electric shock and fire.
- Check that the input power supply is OFF before starting the wiring work. Otherwise, there is a risk of electric shock.
- When carrying out wiring work again after the power has been ON, check that the motor is stopped, and wait at least 5 minutes after powering OFF before starting the work. Otherwise, there is a risk of electric shock.
- Use an EN60947-2-compliant no-fuse breaker and earth leakage circuit breaker (with overcurrent protection). Otherwise, there is a risk of electric shock and fire. For the capacities of circuit breakers, refer to “9.2 Overall Wiring Diagram”.
- Ground the grounding terminals in accordance with the law in the country concerned. Otherwise, there is a risk of electric shock and fire. Make a direct connection without going through a circuit breaker.
- Make sure that no conductive foreign objects such as screws or metal scraps, or combustible foreign matter such as wood debris or oil, get inside the controller. Otherwise, there is a risk of electric shock, fire, and accidents.
- Never use the product in a location where water will get onto it, in a corrosive atmosphere, or an atmosphere containing inflammable gas, or near flammable materials. Otherwise, there is a risk of electric shock and fire.
- Do not damage harnesses, apply strong forces to them, rest heavy objects on them, trap them or bend them excessively. Otherwise, there is a risk of electric shock and breakage.
- To move this product, use the eye bolts. Hoisting it by the pump piping, for example, will pose a danger of the product falling or overturning.
- Do not install or run this product while it is damaged or has missing parts. Otherwise, there is a risk of accidents.

▲ CAUTION

- Strictly follow the requirements for the installation environment. Otherwise, there is a risk of fire and accidents.
- Install it at a location that can bear its weight. Otherwise, there is a risk of accidents.
- Do not expose terminals or other parts to static electricity. Otherwise, there is a risk of failures.
- Check that the input power supply voltage is within the rated voltage range. Otherwise, there is a risk of fire and accidents.
- Check terminal pinouts and terminal codes, and make error-free connections.
- Carry out withstand voltage tests at DC 2kV or lower. Applying voltages higher than this may cause damage.
- Do not perform Megger testing on control circuits. Otherwise, there is a risk of damage.
- Take measures to ensure that sensors and devices in the vicinity do not malfunction due to electromagnetic noise. Otherwise, there is a risk of accidents.
- Do not subject this product to strong impacts. Otherwise, there is a risk of accidents.
- Do not climb onto the product, or rest any heavy object on it. Otherwise, there is a risk of electric shock, accidents and breakage.
- Ensure that this product's environment remains within the permissible ambient temperature and humidity ranges. Otherwise, there is a risk of failures and shortening of service life.

1.5.2 Operation

▲ DANGER

- Do not operate switches with wet hands. Otherwise, there is a risk of electric shock.
- While the product is powered up, do not change the wiring, or connect/disconnect terminals, etc. Otherwise, there is a risk of electric shock, accidents and damage.
- Do not turn on and shut off the power frequently. Otherwise, there is a risk of failures.

▲ CAUTION

- Set the pressure and flow rate such that they do not exceed the permissible range for the machine. Otherwise, there is a risk of accidents.
- Before running the product, set parameters appropriate for the machine. Otherwise, there is a risk of injury, and failures of the machine.
- Before running the product, ensure that you will be able to effect an emergency stop at any time. Otherwise, there is a risk of injury, and failures of the machine.
- When a power outage occurs, do not approach the machine since it is possible that it will suddenly resume motion after the power is restored. Otherwise, there is a risk of injury. It is advisable to set the start/stop signals to positive logic (see "12.2 [P00: DI_A] Switching the Effective Logic for the Start/Stop Signal") for starts to ensure safe restarting.
- While the product is powered up, and for some time after shutting the power off, the heat-radiating fins and electronic devices will be hot, so do not touch them. Otherwise, there is a risk of burns.

1.5.3 Maintenance inspections

▲ DANGER

- Maintenance inspections must be performed by an appropriately qualified technician. Otherwise, there is a risk of electric shock and injury.
- Check that the input power supply is OFF before starting the work. Otherwise, there is a risk of electric shock.
- Check that the motor is stopped, and wait at least 5 minutes after powering OFF before starting the work. Otherwise, there is a risk of electric shock.
- While the product is powered up, do not change the wiring, or connect/disconnect terminals, etc. Otherwise, there is a risk of electric shock, accidents and damage.

▲ CAUTION

- Wear protective glasses and gloves while carrying out the work.
- Do not touch the controller board directly. Otherwise, it could be damaged by static electricity.
- Carry out withstand voltage tests at DC2kV or lower. Applying voltages higher than this may cause damage.
- Do not perform Megger testing on control circuits. This could damage the product.
- Do not disassemble this product. Otherwise, there is a risk of electric shock and injury.

1.5.4 Disposal

▲ CAUTION

- When disposing of this product, entrust it to a specialist contractor as general industrial waste.

Chapter 2. FEATURES AND CONSTRUCTION

2.1 Energy Savings

By adopting a highly efficient IPM motor drive system that is an original development by Daikin, the energy efficiency of the electric motor section has been increased.

The Daikin hybrid hydraulic system “ECORICH” is a “friendly system for both people and the environment”. ECORICH realizes revolutionary energy-saving characteristics and low noise by combining advanced hydraulic technology and motor/inverter technology.

Draft

2.2 Nomenclature

2.2.1 Models

Controller option

Unit option

(a)	(b)	(c)		(d)		(e)	(f)	(g)	(h)		(i)	(j)	(k)	(l)	(m)	(n)
EHU	**	**	–	40	–	*	*	*	*	–	*	*	*	*	*	*

(a) Model

- EHU: EHU series

(b) Maximum discharge rate

- 14: 14 L/min (4 MPa only)
- 25: 25 L/min
- 30: 28.5 L/min (7 MPa only)

(c) Maximum operating pressure

- 04: 4.0 MPa - 07: 7.0 MPa

(d) Design number

- 40: #40 series

This progresses with model changes.

(e) Power supply input specifications

- (None) : Standard (3-phase, 200 V)

(f) Control power supply option

- (None) : Standard (none)
- S: Power and control system separation

(g) Communications option

- (None) : Standard (none)
- C: RS422/485 communication
(The factory default setting is RS422 communication.)

(h) Optional function

- (None) : Standard (none)

(i - N)

Non-standard unit control number

- (None) : Standard product
- 3-digit number or codes for unit options
- Code combination comprising up to 6 digits of alphabetic characters

Unit option code

Code	Description
F	Water fill test tank
M	Water leak test tank
B	Oil filler port, yellow
G	Oil level gauge guard (yellow)
E	Oil level gauge guard (black)
J	Microseparator
K	Thermometer
L	Level switch (NO contact)
H	Level switch (NC contact)
P	Temperature switch (NC contact)
A	With plate compatible with #30 ECORICH

Notes on Nomenclature

- (1) If there is no option, the code ends at (d).
Example: EHU2504-40
- (2) When a unit option is added to the basic unit, one letter of the alphabet "N" is inserted.
Example: EHU2504-40-N-(unit option)
- (3) When a controller option is selected, the relevant letters of the alphabet (from 1 to 4 characters) are allocated.
Examples: EHU2504-40-C-(option)
EHU2504-40-SC-(option)
- (4) If there is no unit option, the code is terminated at the controller option, and "-" (the hyphen) is deleted.
Example: EHU2504-40-SC
- (5) Regarding codes for other options or non-standard unit control number:
 - (1) Codes for other options shall comprise up to six digits of alphabetic characters, in ascending sequence with left-alignment.
 - (2) Non-standard unit number shall comprise three numerical digits.
 Examples: -BFGJKL, -123
 * (1) and (2) shall not be combined. Bad example: -BG001

2.2.2 Manufacturing number

(i)	(j)		(k)		(l)
**	**	-	**	-	*****

- (j) Hardware change history
- (k) Software change history
- (l) Month/year of production
- (m) Serial number

Chapter 3. PRODUCT SPECIFICATIONS AND CONDITIONS OF USE

3.1 Product Specifications

Product Model	EHU1404	EHU2504	EHU2507	EHU3007
Power rating (kW)	0.75	1.5	2.2	2.8
Maximum operating pressure (MPa)	4.0		7.0	
Operating pressure adjustment range (MPa)	1.5 - 4.0		1.5 - 7.0	
Maximum flow rate (*1) (L/min)	15.2	25.1		28.5
Maximum rotational speed (rpm)	3800	4400		5000
Operating flow rate adjustment range (*1) (L/min)	2.5 - 15.2	3.5 - 25.1		3.5 - 28.5
Tank capacity (L)	18			
Mass (kg)	26		29	
External dimensions (mm)	432 (w) × 328 (d) × 487 (h)			
Coating color	Black * Purchased parts, etc.: standard color of the equipment manufacturer			
Discharge port size	Rc3/8 1 location			
Return port size	Rp1/2, 2 ports (in the oil)/1 port (above the oil level)			
Return port size (above the oil level)	Rp1, 1 port			
Digital input (3 channels)	Photo coupler insulation, DC +24 V (max. 27 V) 5 mA, positive or negative common			
Digital output (1 channel)	Photo coupler insulation, open collector output, DC+24 V (max. 27 V) 50 mA max., positive or negative common			
Alarm output (1 channel)	Relay output, contact capacity: DC30 V max. 1A, ALM NO: open when abnormal/ALM NC: closed when abnormal/COM: common			
Communications port (RS-485/RS-422)	Serial communications port * Can be used only with communications option			
Communications port	(UART): Communications port for service * For communications with a personal computer, a dedicated USB-UART communications converter is required.			

*1 The maximum flow rate is the theoretical value, not the guaranteed value.

▲ CAUTION

- The factory default setting is the maximum flow rate.
- The pressure and flow rate can be set beyond the adjustment ranges stated above, but be sure to use the product within the operating pressure range and operating flow rate range stated above.
- This hydraulic unit incorporates a high-pressure safety valve, and its factory default pressure setting is 1.5 MPa. Adjust this setting according to the actual pressure used, by following the procedure given in “High-pressure Safety Valve Adjustment Instructions”. The same applies when there is a need to minimize the surge pressure when an actuator operates.
- Restrict continuous use at the maximum pressure to 5 L/min or less.
- Refer to the specification documents (External dimension sheet) for other specifications.

3.2 Conditions of Use

Useable oil ^(Note 1)	<ul style="list-style-type: none"> • Mineral-oil based hydraulic oil (For the recommended brand, see our “DAIKIN OIL HYDRAULIC EQUIPMENT Catalog (HK196)”.) • Viscosity grade: ISO VG 32 to 68 • Dynamic viscosity range: 20 to 88 mm²/s (recommended values), 15 to 400 mm²/s (usable range) • Contamination: Within NAS class 10, water content 0.1%vol max. • Tank oil temperature range: 15 to 50°C (recommended values), 0 to 60°C (usable range) ^(Note 3)
Input power supply ^(Note 2)	• AC 3-phase, 200/200/220 V, 50/60/60 Hz (Permissible voltage fluctuation: ±10%)
Discharge port	Rubber hose (minimum 600 mm) connection
Operating ambient temperature	0 to 40 °C
Storage ambient temperature	-20 to 60 °C
Operating ambient humidity	Under 85% RH (no condensation)
Operating altitude	1,000 m maximum
Installation site	Indoors (Be sure to fix with bolts, etc.)
Other	<ul style="list-style-type: none"> • Be sure to install no-fuse breakers at all poles (3 poles or 2 poles) at the main circuit power supply side (primary side). • Wire electrical connections so as to satisfy JIS B 9960-1 (European standard EN60204-1). • Turning the power ON/OFF within a short time will significantly shorten the life of the controller. If operation is to be repeatedly started/stopped with an interval of shorter than 8 minutes, use start/stop signals. Note, however, that they must be used with an interval of at least 0.5 seconds between the stop command and restarting. • Be sure to ground ground terminals in accordance with the law in the country concerned. Make a direct connection without going through a circuit breaker.

Note 1: Hydraulic oil must be the mineral-base oil type (e.g. water-glycol can't be used).

Note 2: Note that if there is fluctuation on the plus side even if it is within the tolerance, an overvoltage alarm that stops operation may occur at the response, depending on the operating conditions of the main machine and the load conditions. Note that if there is fluctuation on the minus side even within the permissible fluctuation of the power supply voltage, it can adversely affect the output characteristics.

Note 3: When using the product outside the recommended operating temperature range, the pressure pulsations may become large and the discharge rate may decrease, but this is not abnormal.

3.3 PQ Representative Characteristic Diagrams

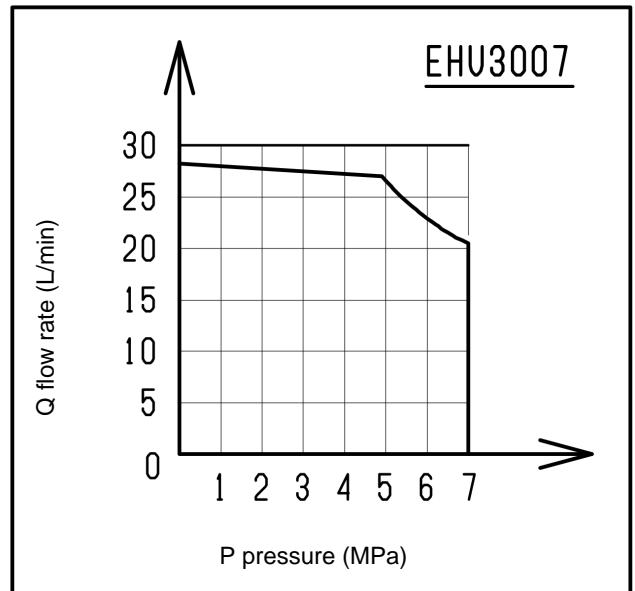
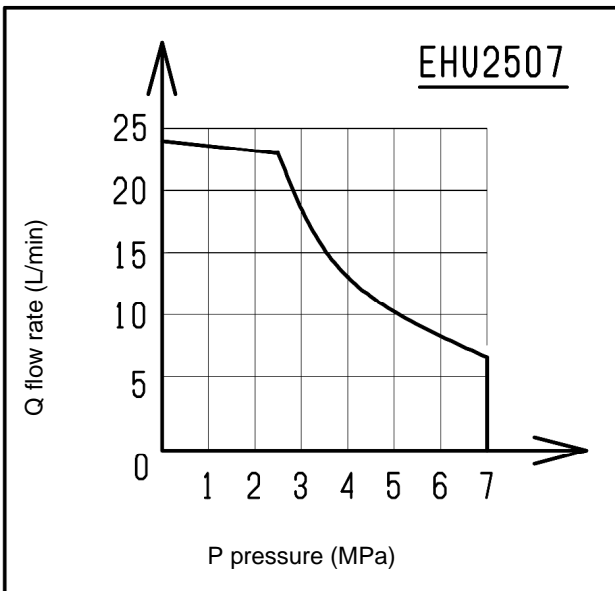
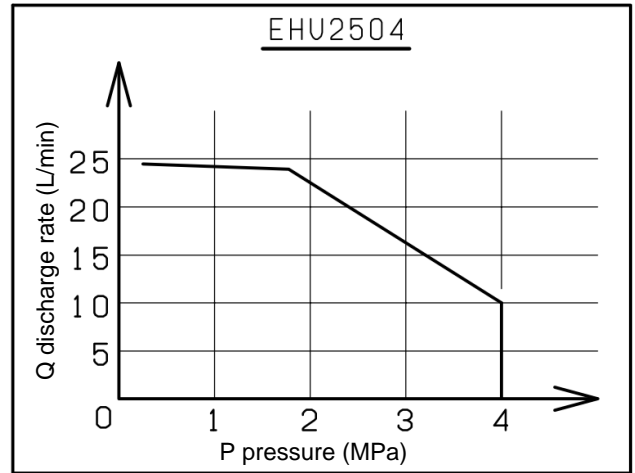
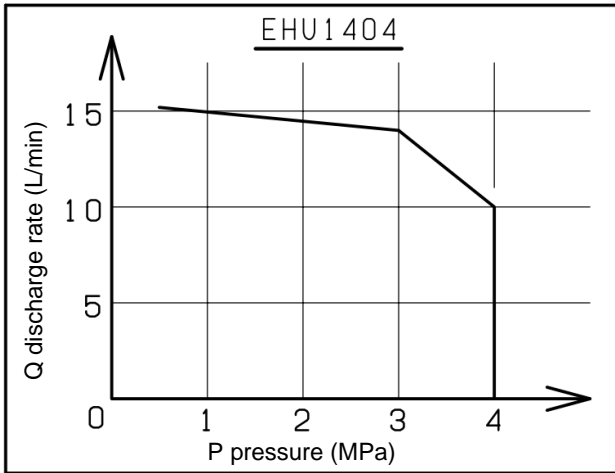

- *1 The above are the representative characteristics with oil type VG32 and a temperature of 40°C.
- *2 The above PQ characteristics diagrams show the operating range in terms of actual flow rates.
- *3 Restrict continuous discharge flow rate at the maximum pressure to 5 L/min or less.

3.4 External Dimensions

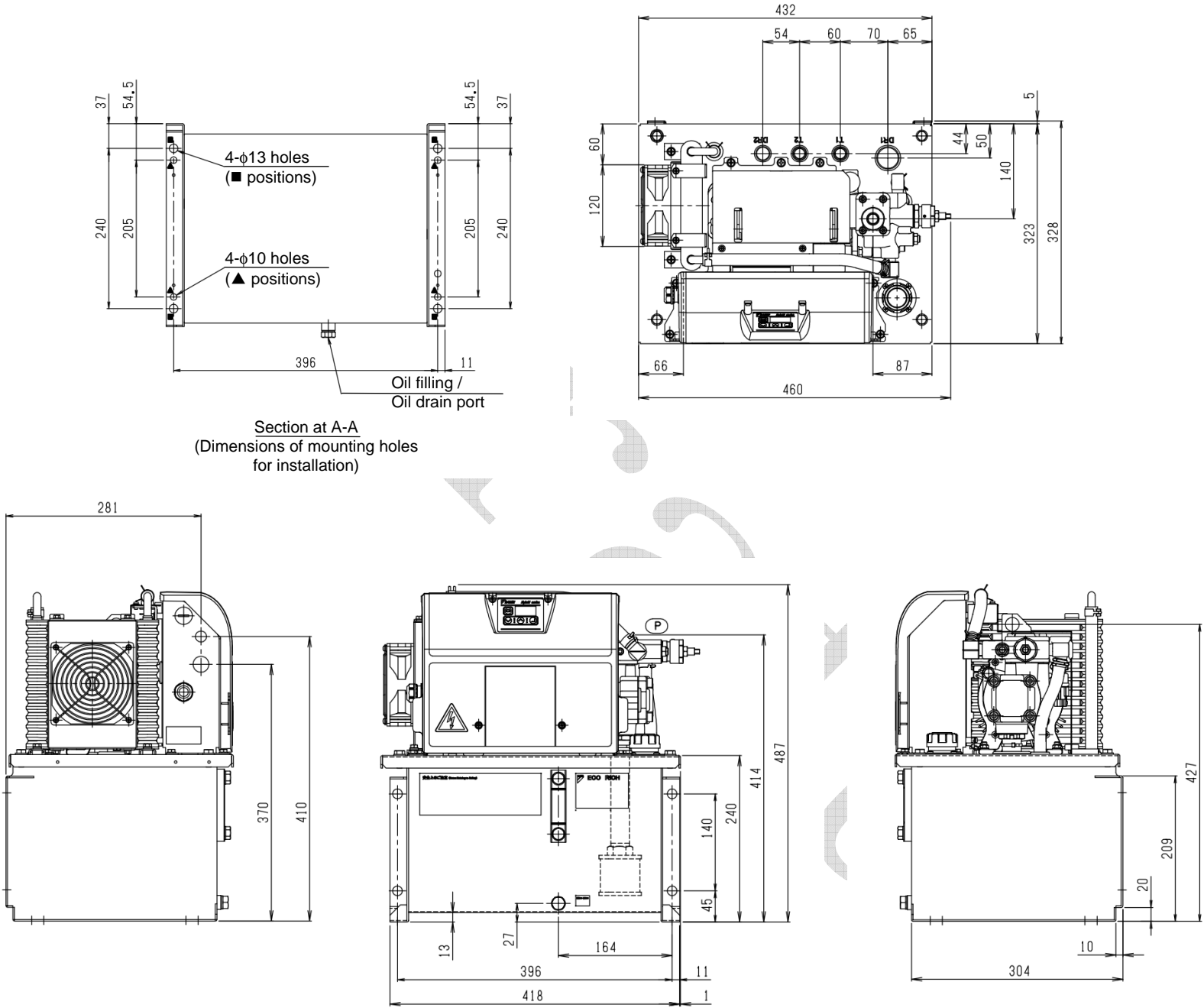

Chapter 4. COMPONENT PARTS AND PART NAMES

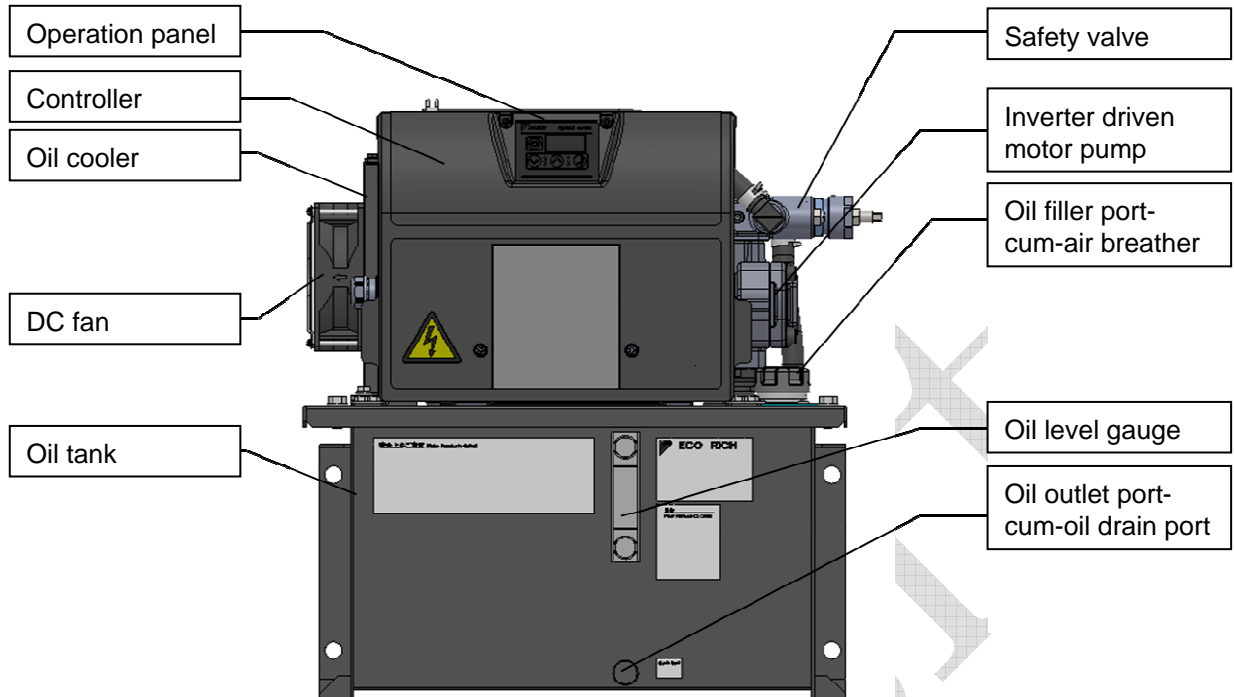

Front View of Unit

Chapter 5. PROCEDURE FOR STARTING UP

The procedure for starting up is as follows.

1. Check See “Chapter 6 CHECKS UPON RECEIVING THE PRODUCT”.
2. Transportation/installation See “Chapter 7 TRANSPORTATION/INSTALLATION”.
3. Piping See “Chapter 8 HYDRAULIC PIPING”.
4. Wiring See “Chapter 9 ELECTRICAL WIRING”.
5. Powering on See “Chapter 10 TRIAL RUNNING”.
Be sure to check the following points before turning the power on.
 - Is the product installed correctly?
 - Has the piping been done correctly?
 - Has hydraulic oil been supplied?
 - Has the wiring been done correctly?
 - Is the power supply voltage correct?
6. Flushing operation See “Chapter 10 TRIAL RUNNING”.
7. Replacement with new oil See “Chapter 10 TRIAL RUNNING”.
8. Air bleeding See “Chapter 10 TRIAL RUNNING”.
9. Operation check Check the operation of the actuators.
Referring to “11.5 Setting Mode”, change the pressure/flow rate settings as necessary.

Chapter 6. CHECKS UPON RECEIVING THE PRODUCT

6.1 Check on the Contents of the Packaging

▲ CAUTION

- Check that the product is the right way up, then unpack it. Otherwise, there is a danger of falling and breakage.

When the product has been unpacked, check that the following items are present.

- Hydraulic unit body 1 piece
- Quick instruction manual 1 copy

6.2 Check on the Model

▲ CAUTION

- Check that the model designations indicated on the product nameplates of the motor pump and controller match the ordered product. Using a product that is incorrect will result in breakage.

Check, with the product nameplates, that the actual item matches the ordered product. For details on model designations, see “2.2 Model Codes”.

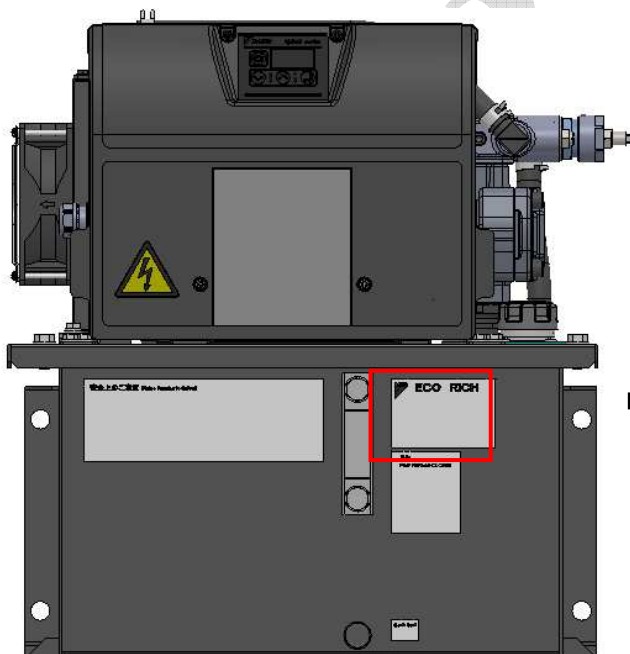

< Front View of Unit >

This is the model code of the product.
Check that it matches the ordered product.

DAIKIN		ECO RICH			
		EHU3007-40			
MFG No. :		※			
MASS	: 29 kg	INSULATION CLASS : B			
MAX. FLOW	: 28.5 L/min	V	Hz	A	PF
MAX. PRESSURE	: 7.0 MPa	3 φ 200	50	10.3	0.92
CONT. OPERATION (at 7.0 MPa)	: 5 L/min	3 φ 200	60	10.3	0.93
IP CODE	: IP44	3 φ 220	60	9.7	0.92
MANUAL No. :	PIM00496				
DAIKIN INDUSTRIES, LTD. MADE IN JAPAN					

< Example Product Nameplate >

Chapter 7. TRANSPORTATION/INSTALLATION

7.1 Transportation

7.1.1 Transportation in the packaged state

To transport the product in the packaged state, lift by using the handgrip openings in the cardboard, and transport it on a dolly, for example.

The weight in the packaged state is indicated on the label affixed to the side face.

▲ WARNING

- Transport the product with material handling equipment appropriate for the packaged state. Otherwise, there is a danger of falling or toppling over.
- This is a heavy item and should therefore not be lifted by one person alone.
- Before lifting the product, check its weight and the position of its center of gravity. Otherwise, there is a danger of falling or toppling over.

7.1.2 Transportation of the product

When transporting the product, hoist it by using the holes provided for hooks at two locations. Using other locations will lead to a risk of falling/toppling over.

Check the mass of the hydraulic unit, and make sure that the hoisting load is within the rated load of the hoisting equipment.

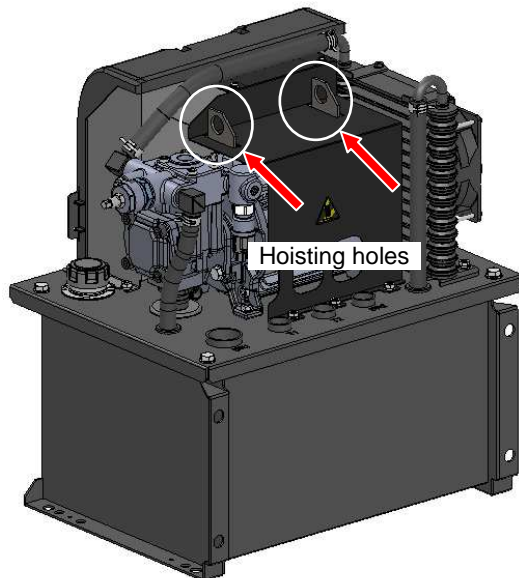

◆ Product Masses (Excluding Hydraulic Oil)

Product Model	Mass [kg]
EHU1404	26
EHU2504	
EHU2507	29
EHU3007	

▲ DANGER

- Hoisting the product using locations other than the hoisting holes (the pump, piping, etc.) risks the product falling or toppling over and is dangerous.
- Check the mass of the hydraulic unit in the table above, and ensure that the hoisting load is within the rated load of the hoisting equipment.

▲ WARNING

- When transporting the product, be sure to hoist it with the two hoisting holes.
- Never approach the product while it is being transported using hoisting equipment. Otherwise, there is a risk of injury due to the product falling or toppling over.

▲ CAUTION

- Do not hoist or move the product while there is oil in the tank. This could impair safety and/or performance due to the product falling or toppling, or oil leakage or inclusion of air.
- This product is precision equipment. Do not drop it or subject it to any strong impact. Otherwise, there is a risk of breakage.
- When transporting the product, do not hold wire harnesses, piping, solenoid valves, etc. Otherwise, there is a risk of accidents due to breakage and falling.
- Fix the product firmly so that it will not move due to vibration or external forces during transportation.

7.2 Installation

7.2.1 Secure the space for air intake/exhaust

Install the unit at a well ventilated location where heat will not build up, and secure a surrounding space of 10 cm from each of the four end faces of the unit. Also take care that the temperature of the intake air complies with the stipulated ambient temperature (40°C max.).

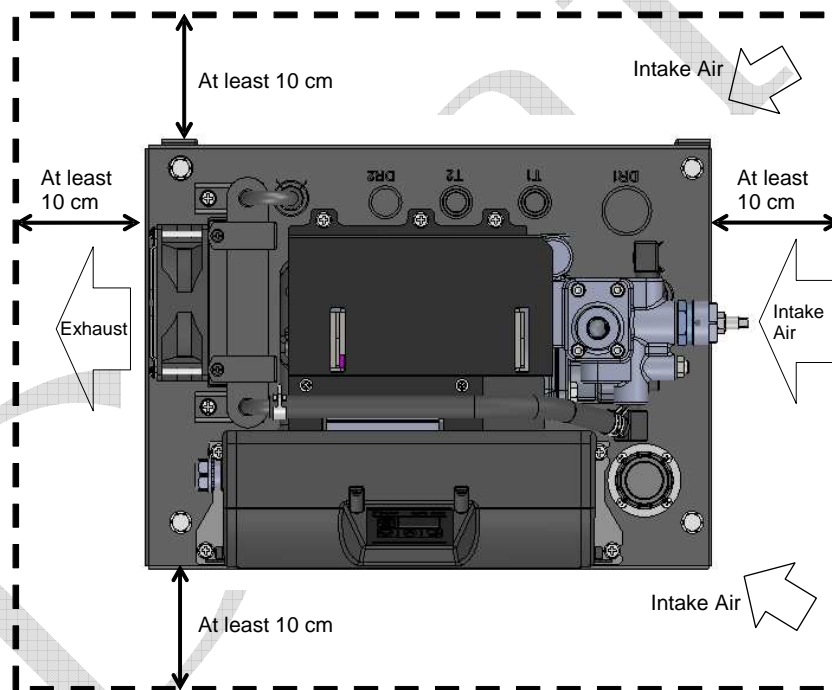

▲ WARNING

- If the intake air/exhaust spaces described above are not secured, the heat exchange function of the oil cooler/DC fan will deteriorate, and the oil temperature and temperature of the hydraulic devices will become abnormally high, posing a risk of fire. Be sure to secure the space for air intake /exhaust.
- Touching hot parts can cause burns.
- Provide sufficient maintenance space so that working postures will not be uncomfortable.

▲ CAUTION

- If the intake air/exhaust spaces described above are not secured, the motor and controller will reach high temperatures and the lives of the devices will be significantly shortened. Be sure to secure the space for air intake /exhaust.
- If the intake air/exhaust spaces described above are not secured, the motor and controller will reach high temperatures, temperature protection will be actuated and the product will stop running.
- Continuing to use the product while it is at a high temperature will result in trouble affecting, and shorten the lives of, the electrical components as described previously, but also hydraulic devices such as pumps and valves. It will also promote deterioration of the hydraulic oil, shortening the service life of the oil.

7.2.2 Securing the hydraulic unit

Secure the hydraulic unit either on a level platform or level floor, that will not be affected by the vibration of the main machine (M10 bolts at 4 locations). For details on the mounting method and position, refer to the Delivery Specification (outside drawing).

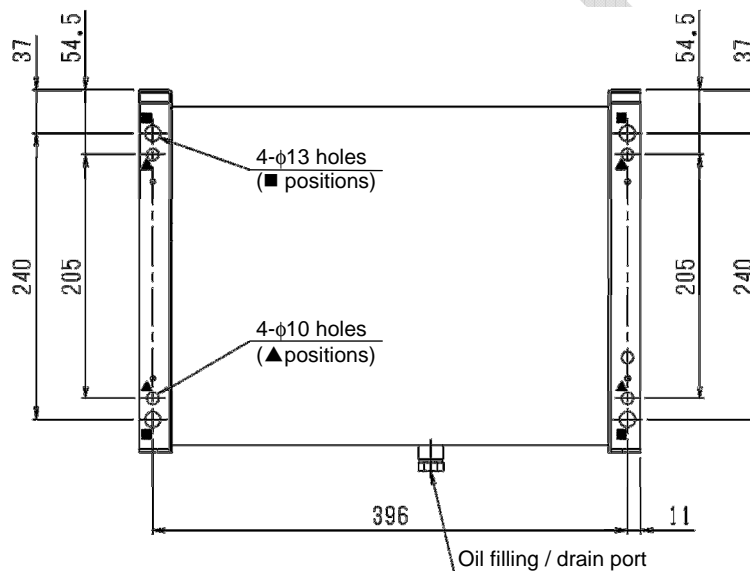

Installation mounting hole dimensions (seen from the bottom)

▲ WARNING

- If the hydraulic unit is not secured, it may topple over or move as a result of reactions to the hydraulic pressure in the piping and so on, imposing a hazard. Be sure to secure it with bolts, etc.

▲ CAUTION

- Installing the product on a sloping surface may cause oil leakage and inclusion of air in the oil, leading to abnormal noises and shortening of equipment life. Be sure to install it on a level surface.

Chapter 8. HYDRAULIC PIPING

8.1 Piping

Be sure to connect piping at the following ports. Details on the piping positions can be found in the outside view drawing. Use hoses for the piping work, and fasten them with sealing tape.

<Piping Specifications>

Piping port	Piping size	Recommended hose withstand pressure	At shipment
P	Rc 3/8	10.5 MPa	Plastic plug
DR1	Rp 1	1.5 MPa	
DR2	Rp 1/2	1.5 MPa	
T1	Rp 1/2		
T2	Rp 1/2		

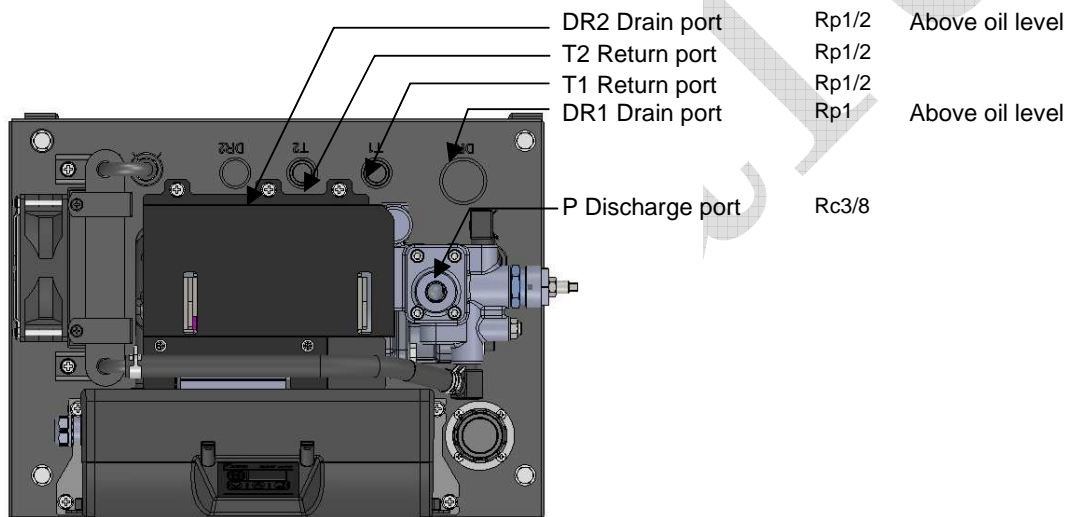

▲ DANGER

- When connecting hoses, allow at least the hydraulic hose manufacturer's recommended bend radius. Regarding the method for securing the hoses, fix them as recommended by the hose manufacturer.
- When doing the piping work, make the piping strong enough for the pressures to be used.

▲ CAUTION

- Use hoses for the piping to this product.
- Connect the hoses without any twisting.
- In cases where excessive strain is likely to occur due to the weight of the hose, support the hose.

8.2 Filling with Hydraulic Oil

- Remove the cap of the filler port cum air breather by turning it counterclockwise, then pour clean hydraulic oil (within NAS class 10) into the tank. The volume of oil should be that sufficient to bring the float to between the red line and yellow line.
- Use a hydraulic oil that conforms to the conditions described in “3.1.1 Product Specifications”.

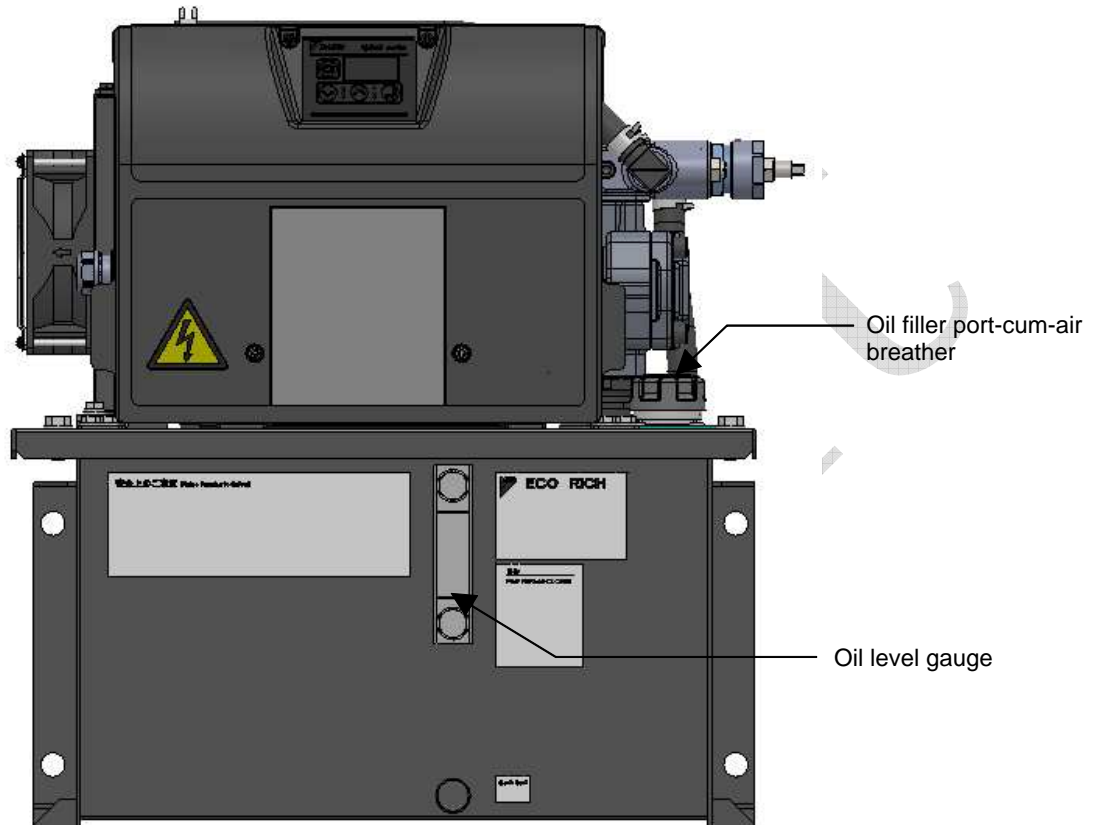

⚠ CAUTION

- Running the product while the tank is not full of oil will cause seizure and/or wear of the pump, leading to breakage.
- During the initial operation of the machine, oil is supplied to the hydraulic circuits at the machine side and the oil in the tank may decrease. Add oil to bring the height of the oil level to within the stipulated range.
- Depending on the hydraulic circuits at the machine side, the fluctuations in oil level in the tank may become large, and oil may overflow from the tank or the oil level may drop. Adjust while watching the oil level gauge to achieve the optimum oil level.

Chapter 9. ELECTRICAL WIRING

In order to run this product, the main power supply has to be connected. Also connect input/output signal cables as necessary.

- Connect the main power supply and input/output signal cables after removing the exterior cover. To remove this cover, unscrew the four M4 cross recessed screws. After completing the wiring work, mount the exterior cover before use. The recommended tightening torque is 1.0 N·m.
- When wiring the main power supply and input/output signal cables, pass the cables through the specified cable ports.
- Fit a no-fuse breaker conforming to European standard EN60947-2 to the source power supply of the hydraulic unit in order to protect the electrical circuits against short circuits, overcurrents, etc., and to prevent electric shock.
- Use a power supply connection device that has a switch specification where the distance between contacts is at least 3 mm for all three poles when the switch is OFF.

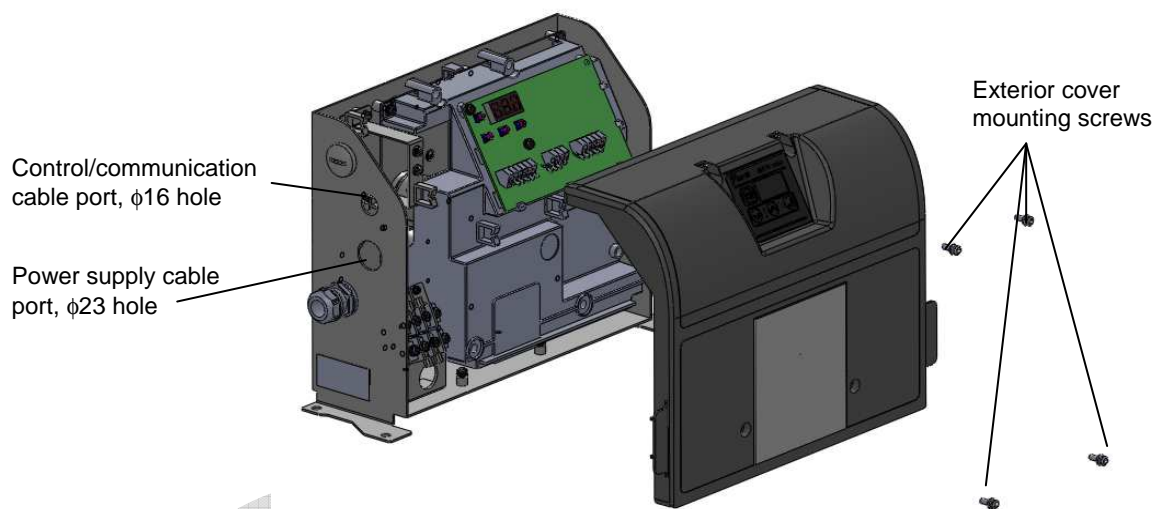

⚠ DANGER

- **Fit a safety device in the form of a no-fuse breaker conforming to European standard EN60947-2 to the source power supply of this product in order to protect the electrical circuits against short circuits, overcurrents, etc., and to prevent electric shock (for the capacity for each model, see “9.3 Installation of the Breaker”).**
- **Be sure to ground ground terminals in accordance with the law in the country concerned. Make a direct connection without going through a circuit breaker.**
- **Turn the breaker at the source power supply side OFF and wait at least 5 minutes before starting the wiring work. Otherwise, there is a risk of electric shock.**
- **Do not apply any excessive power supply voltage, beyond the power supply specifications of this product. This will damage the controller.**
- **Perform the wiring so as not to cause short circuit or ground faults between terminals and electric wires. Otherwise, there is a risk of electric shock and fire.**
- **When stripping electric wires, take care not to damage the conductors.**
- **For wiring, use multi-conductor cables and cable clamps, and do the work so as to satisfy protection class IP54 or better.**

9.1 Procedure for Mounting Exterior Covers

After connecting the main power supply and input/output signal cables, the exterior cover needs to be mounted. Mount it by following the procedure below.



Exterior cover

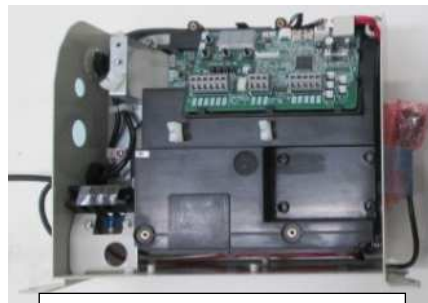

Controller box

- ① Engage the corners of the controller and corners of the cover together and ② close the cover.

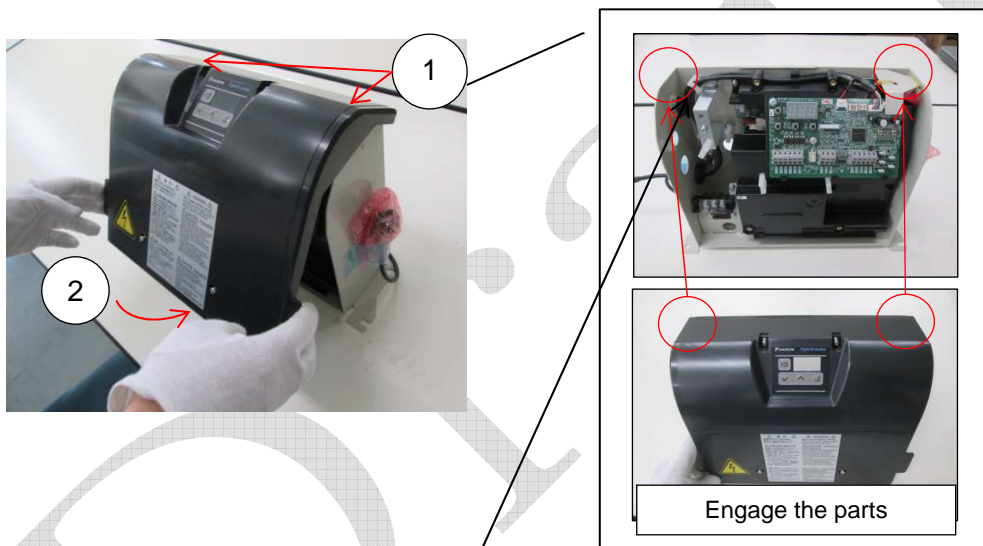

- ③ Holding the grips at the left and right of the cover, engage the cover with the bottom of the controller.

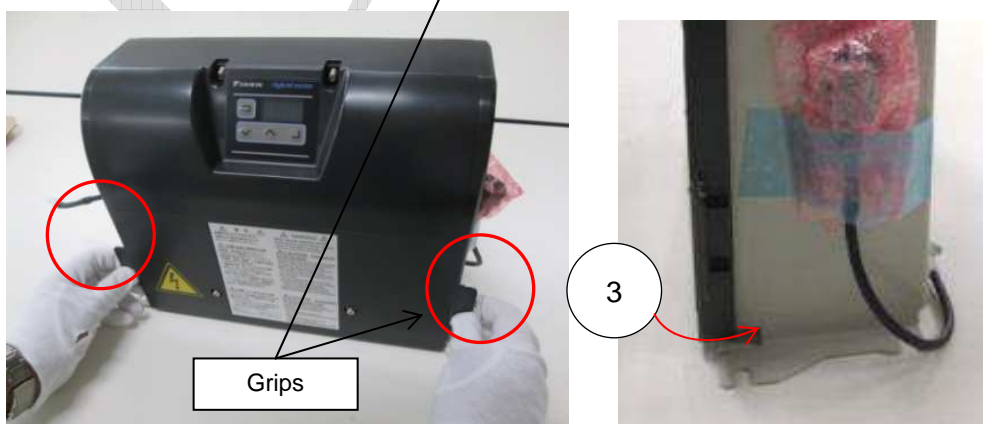

④ Press in the vicinity of the two screws at the bottom of the exterior cover to position it.

* When pressing the vicinity of the screws, confirm that a clicking sound is heard as the projections on the exterior cover go into the mating parts on the interior cover.

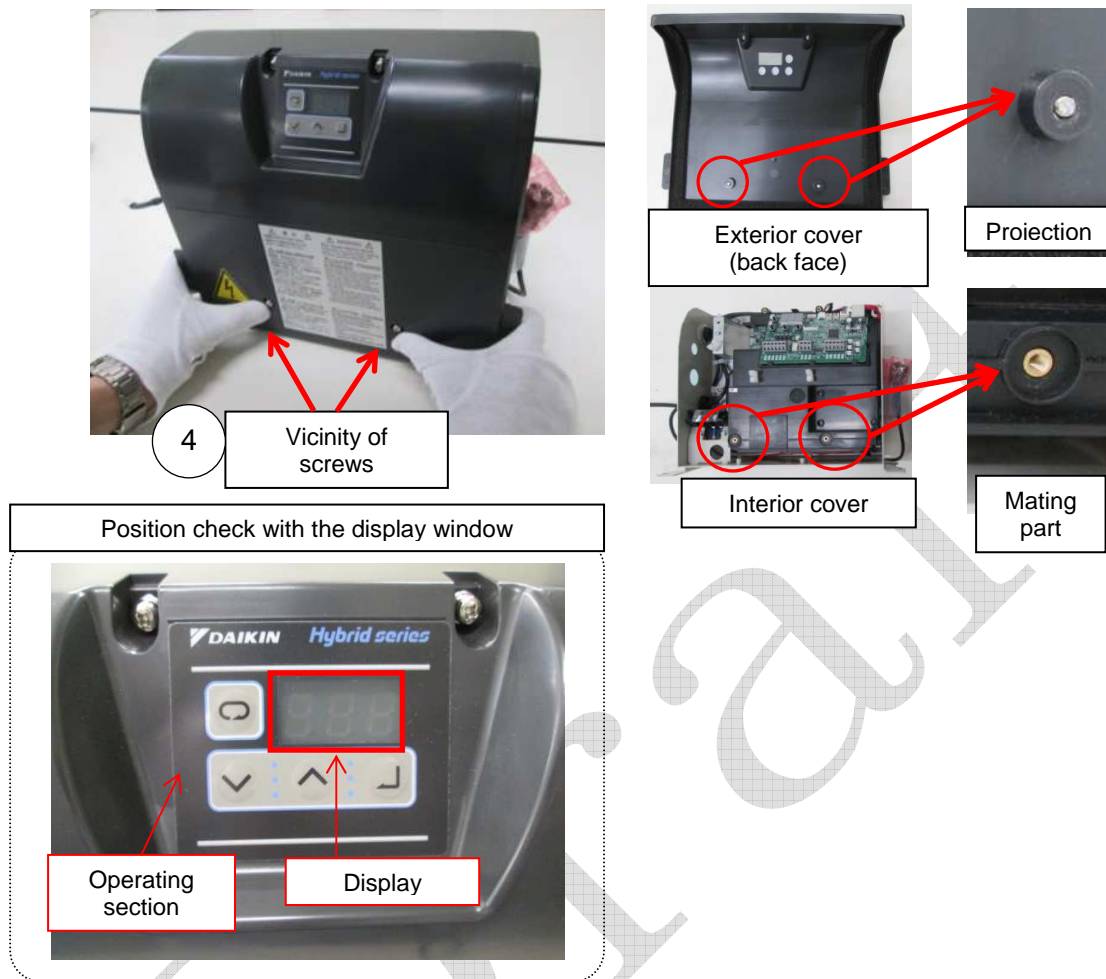

* Check that the 7-segment display is located in the center of the display window in the operating section sheet.



⑤ Tighten the two screws in the lower part of the cover, then tighten the two screws at the top.

9.2 Overall Wiring Diagram

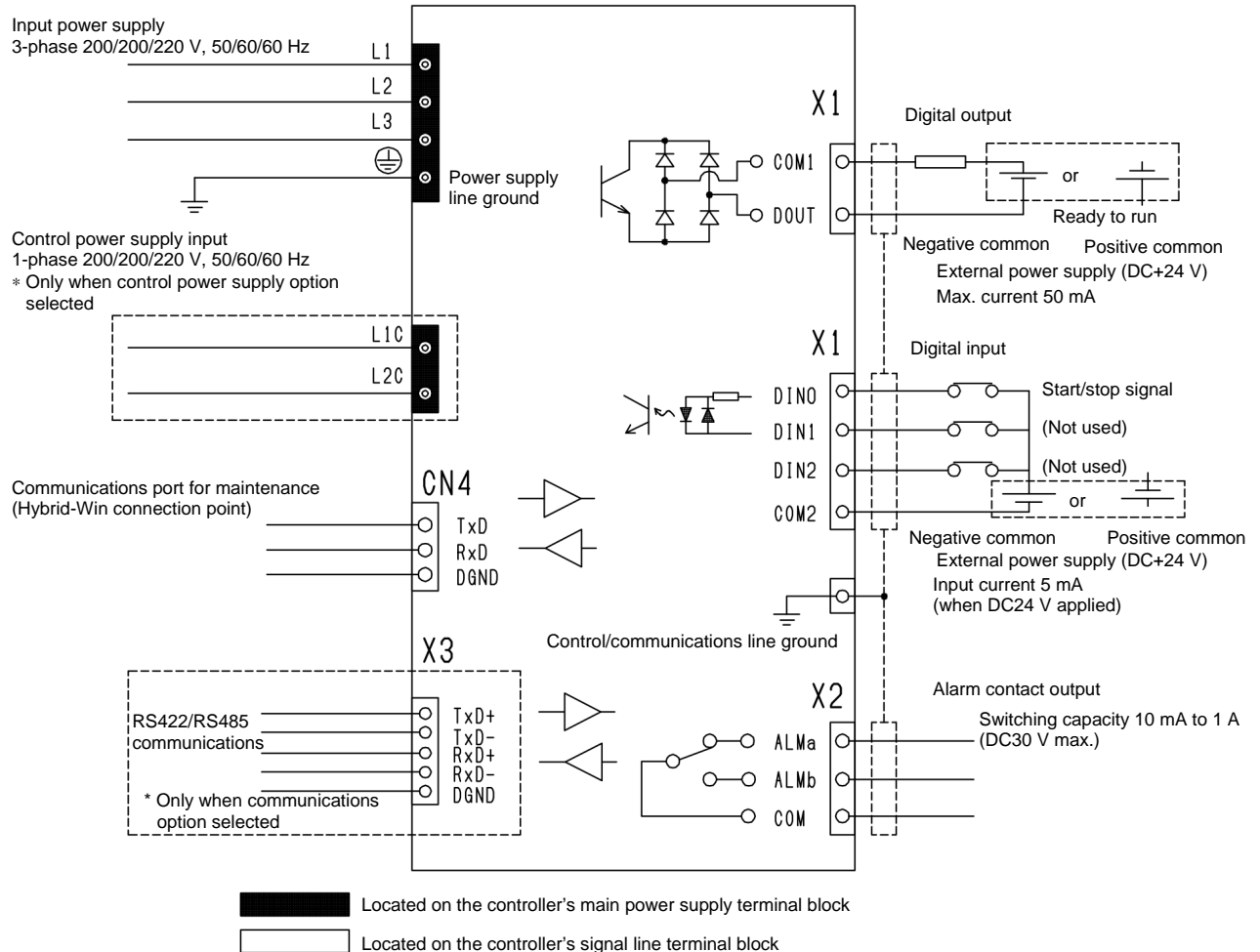

9.3 Installation of the Breaker

In order to prevent power-supply-related accidents, be sure to use a no-fuse breaker conforming to EN60947-2 in the power supply connection line. The rated capacity of the breaker should be as indicated in the table below. There are no inrush currents with ECORICH.

Product Model	Power Supply Voltage and Frequency			Breaker Setting
	3-phase 200 V 50 Hz	3-phase 200 V 60 Hz	3-phase 220 V 60 Hz	
EHU1404-40	6.0 A	5.9 A	5.5 A	15 A
EHU2504-40	7.0 A	7.0 A	6.7 A	15 A
EHU2507-40	4.7 A	4.5 A	4.3 A	15 A
EHU3007-40	10.3 A	10.3 A	9.7 A	15 A

9.4 Connection of the Main Power Supply

- 1) Prepare the power supply cable, crimp terminals (ring-type crimp terminals with insulating cladding), and cable clamps. Crimp a ring-type crimp terminal with insulating cladding onto the end of the cable using a dedicated tool.

<<Recommended Items>>

Models	Cable Specifications	Cable Size	Recommended Cable	Recommended Crimp Terminal	Recommended Cable Clamp
EHU1404 EHU2504 EHU2507 EHU3007	CE	1.5 mm ² or larger	CE362 1.5 mm ² × 4 conductors (KURAMO ELECTRIC)	RBV2-4	OA-W1611 (OHM ELECTRIC) Applicable cable outer diameter: φ9 to φ11
	VCT	2 mm ² or larger	VCT362 2 mm ² × 4 conductors (KURAMO ELECTRIC)		OA-W1613 (OHM ELECTRIC) Applicable cable outer diameter: φ11 to φ13

- 2) Use a ground cable the same size as the power cable or larger.
- 3) Pass the cables through the controller's wiring port to accomplish the wiring work. At the wiring port, use a cable clamp appropriate to ensure the port satisfies protection class IP54 or better.
- 4) Connect the power cable to the terminal block. The screws for connecting the power supply ground are different from those for the power supply cable connection terminals, so take care not to confuse them. The recommended tightening torque is 1.0 N·m.

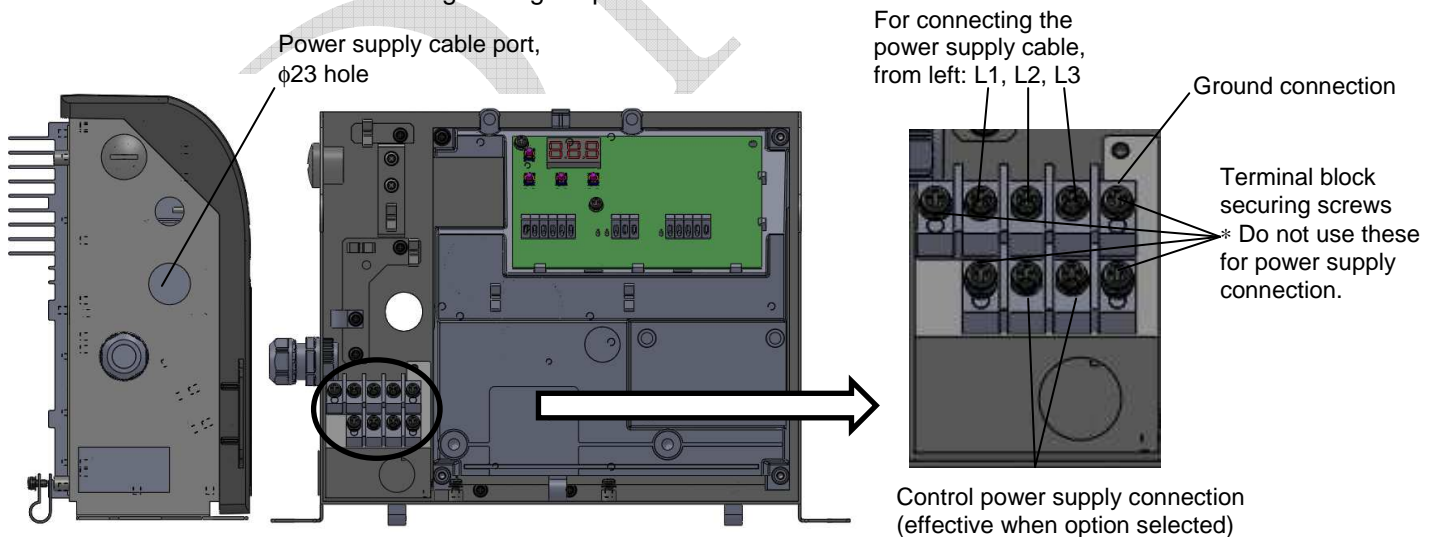

▲ DANGER

- Use an AC power supply matching this product's power supply specifications.
- Use a cable appropriate for the power supply capacity.
- Connect the end of the cable by using a crimp terminal. Use a tool suited to crimp terminals. Crimping faults may result in the cable coming loose during use, short-circuiting accidents, and burnout due to abnormal heat generation.
- Do not use anything other than the terminals provided with this product for connecting the power supply.
- Use an M4 cross-recessed pan-head screw and washer assembly, 8 mm long, for the power supply ground terminal.
- Be sure to ground ground terminals in accordance with the law in the country concerned. Make a direct connection without going through a circuit breaker.
- Do not connect the power supply cable to the input/output signal terminals or ground terminal. This could cause an electric shock or equipment damage.

▲ CAUTION

- This product incorporates an overcurrent protection function internally, so no thermal relay for overcurrent protection is necessary.

9.5 Connection of Input/Output Signal Cables

- 1) Prepare cables and cable clamps. For the cables, use shielded cabtyre cables, and be sure to complete terminal processing of the shielding wire.

<<Recommended Items>>

Cable Size	Recommended Cable	Recommended Cable Clamp
0.3 - 0.5 mm ² (AWG20 - 22)	KVC-36SB 0.3 - 0.5 mm ² (KURAMO ELECTRIC)	OA-W15-07 (OHM ELECTRIC) Applicable cable outer diameter: φ5 - φ7

- 2) Connect the cables through the controller's cable port. At the cable port, use a cable clamp appropriate to ensure the port satisfies protection class IP54 or better.
- 3) Check the specifications of each signal cable, and connect them to the I/O signal terminal block. If measures against loose strands or corrosion at the end of the cable are required, use rod-type crimp terminals with insulating cladding. (Recommended crimp terminal: 216 - 322 (0.3 mm²), 216 - 221 (0.5 mm²), WAGO)
- 4) You are recommended to ground at one side. When grounding inside the controller, crimp a ring-type crimp terminal with insulating cladding onto the end of the cable with a dedicated tool, and connect it with a control/signal cable grounding screw (M4).

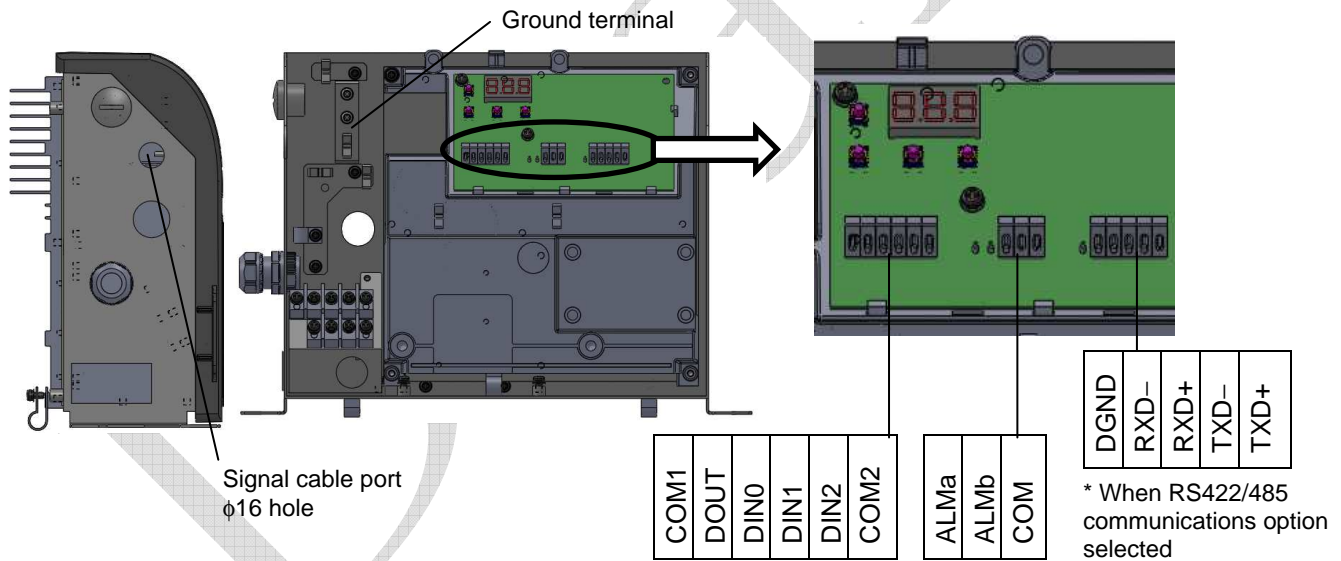

Terminal code	Signal name	Remarks
COM1	Digital output common	See 9.5.2 Digital outputs.
DOUT	Digital outputs	
DIN0	Digital input 0	See 9.5.1 Digital inputs.
DIN1	Digital input 1	
DIN2	Digital input 2	
COM2	Digital input common	

Terminal code	Signal name	Remarks
ALMa	Alarm output, NO contact	See 9.5.3 Contact outputs.
ALMb	Alarm output, NC contact	
COM	Alarm output common	

<<Method for Connecting to the Terminal Block>>

- 1) Push on the spring with e.g. a screwdriver.
- 2) Pushing the screwdriver up will open up the opening for insertion.
- 3) Check the stripped length of the wire, and insert it fully home without making any loose strands.
- 4) Remove the screwdriver or other tool from the lever.
- 5) Lightly pull the wire to check that it is securely connected.

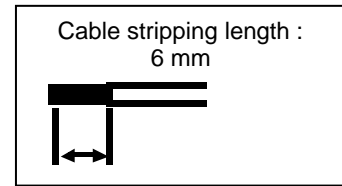

Controller interior Interface board

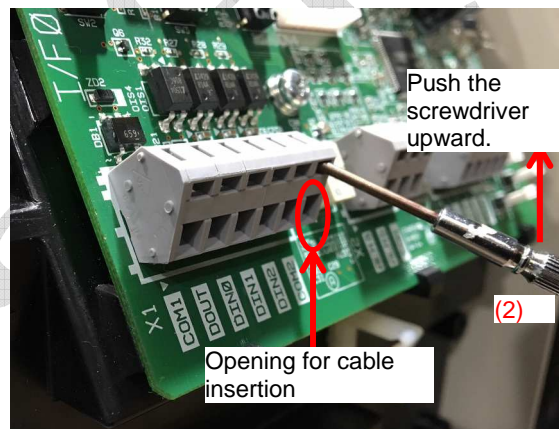
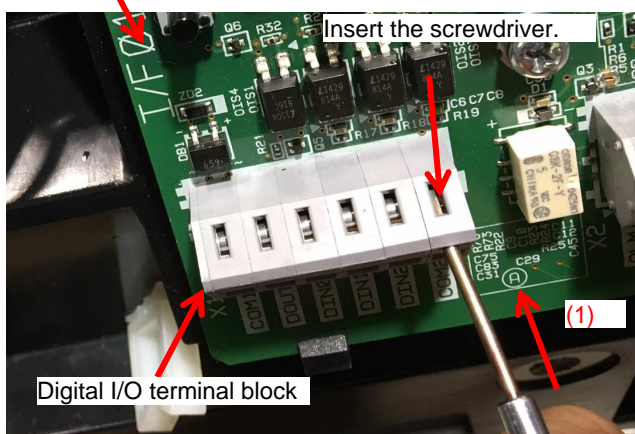

⚠ CAUTION

- Check the specifications of each signal before making the connections.
- Be sure to terminate shielded cables, and connect them to the shielded cable grounding terminal.
- If noise is not eliminated even when connected to the shielded cable grounding terminal, make a single-point grounding connection on your own equipment (disconnect the grounding at the unit).

9.5.1 Digital inputs

These are sequence input signals that control the operations of this unit from an external device. Connect them as necessary by following the information below.

Terminal Name	Signal name	Remarks
COM2	Digital input common	Can be either positive or negative
DIN0	Digital input 0	Start/stop signal(factory default on:start/ OFF:stop)
DIN1	Digital input 1	(Reserved) (Do not connect.)
DIN2	Digital input 2	(Reserved) (Do not connect.)

Note: When a stop command has been input via digital input 0, "STP" is displayed on the panel.

Note: Secure a time of at least 1 minute between stopping and starting the unit.

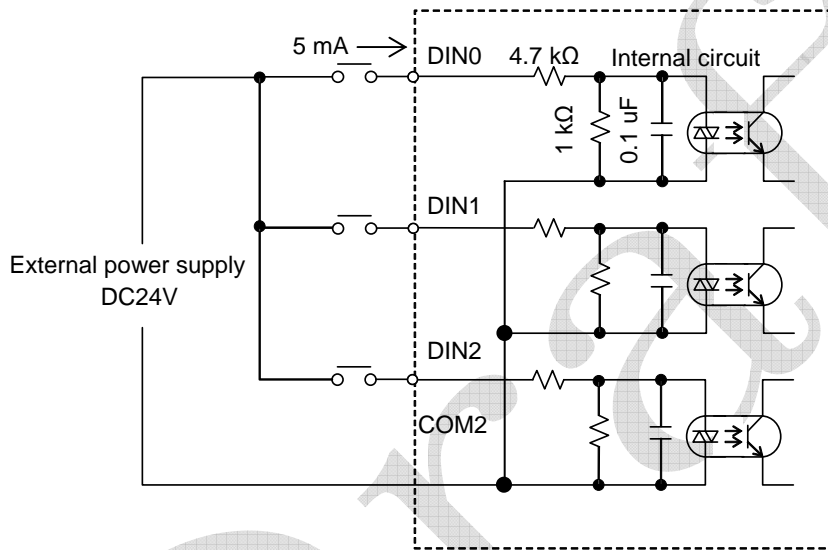

⚠ CAUTION

- Prepare an external power supply that is DC24 V \pm DC1 V/0.5 A minimum.
- It is not possible to supply power from this controller to external destinations.
- The current flowing to each input circuit is 5 mA (typ.). If a circuit is configured with contacts, etc., pay attention to the minimum current for those contacts, etc.

9.5.2 Digital outputs

These are the digital output signals that output the alarm statuses of this unit. Connect them as necessary by following the information below.

Terminal Name	Signal name	Output Content: factory default setting
DOUT	Digital output 1	Function disabled (comes ON when ready to run) * Factory default at 39: 8 The operation changes depending on the value of parameter P39. See 12.4.
COM1	Digital output common	Can be either positive or negative

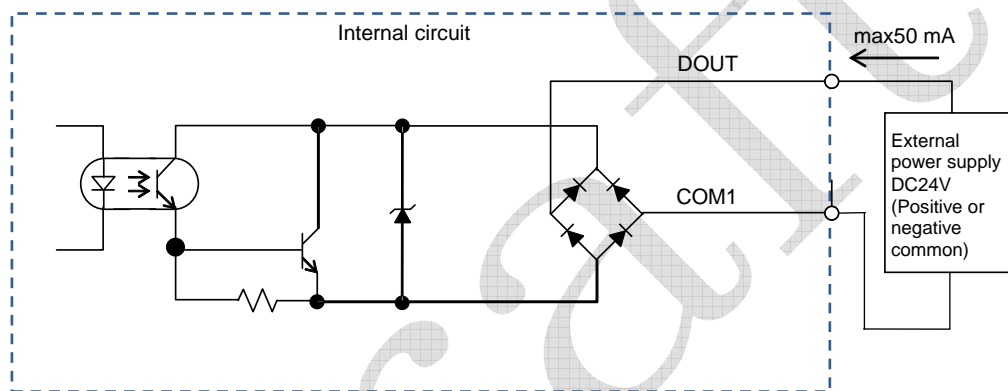

⚠ CAUTION

- Prepare a DC24 V \pm DC1 V/0.5 A power supply externally. It is not possible to supply power from this controller to external destinations.
- The maximum output current of the output circuit is 50 mA (resistance load). Note that driving a load exceeding the permissible current may damage the circuit.
- When driving inductive loads, implement surge protection measures.

9.5.3 Contact outputs

These are the contact output signals that output the alarm statuses of this unit. Connect them as necessary by following the information below.

Terminal Name	Signal name	Output Content: factory default setting
ALMa	Alarm output, NO contact	When an alarm occurs, or L70 (reverse rotation warning) occurs or a hydraulic switch is actuated, the NO contact opens (NC contact closes). The operations vary depending on the values of parameter P39 and P47. See 12.4.
ALMb	Alarm output, NC contact	
COM	Alarm output common	Can be either positive or negative

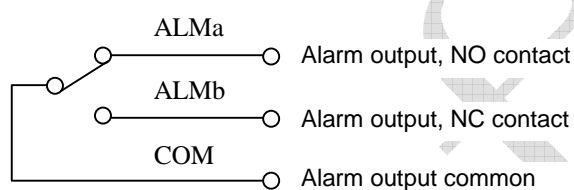

Power ON : Normal status

▲ CAUTION

- The switching capacity of the contact outputs is DC24 V/1 A (at resistance load). Note that driving a load exceeding the permissible current may damage the contacts or other components.
- The minimum applicable load for the contact outputs is DC24 V/10 mA (at resistance load), but this is only a guide to the lower limit where switching is possible with a minute load. The value varies depending on the switching frequency, environmental conditions, etc., so it is advisable to check the actual value.
- When driving inductive loads, implement surge protection measures.
- When an alarm signal is output, take action such as shutting the power off immediately. For details on handling of alarms, refer to "Chapter 13".

Chapter 10. TRIAL RUNNING

▲ CAUTION

- Ensure that the power can be shut off immediately in response to unforeseen events. Either incorporate an emergency stop switch or similar device, or configure a sequence circuit for the main machine for that purpose.
- In the event of unanticipated operation, stop the unit and check safety before restarting the operation.

Check that all the preparations for running have been completed by referring to “Chapter 5 PROCEDURE FOR STARTING UP THE PRODUCT”.

(1) Powering on	Turn the switch on the control panel at the machine to “ON” to supply power to the hydraulic product. This unit starts in about 3 seconds after powering up. Check the following points: A. That the display on the controller’s operation panel lights up B. That the DC fan for the oil cooler is running C. That the pressure indicated on the controller’s operation panel display rises after the sound of the pump running
(2) Flushing operation	When the starting check is completed, connect all the piping except for the actuators in a loop, then flush for about two hours by passing hydraulic oil through the return filter.
(3) Changing the hydraulic oil	Turn the power off, drain all of the hydraulic oil in the tank out through the tank’s oil drainage port, then pour in the stipulated volume of new hydraulic oil through the oil filler port cum air breather. Check the return filter’s indicator, and if it is clogged, change the filter element.
(4) Air bleeding	Thoroughly bleed air from inside the hydraulic circuit. If the air is not completely bled out, cylinders and other actuators may operate abnormally, and there may be abnormal noise from the pump, valves and so on.

▲ CAUTION

- When bleeding the air, oil at high pressure and high temperature may gush out, so care is necessary.

Chapter 11. PANEL OPERATIONS

11.1 Names and Main Functions of Each Part of the Operation Panel

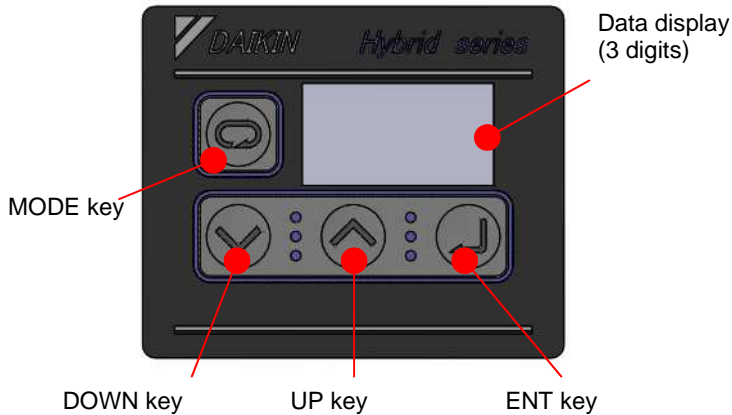

The controller features the 3-digit data display and four key-switches indicated in the figure to the left. The LED display normally shows the current actual pressure (MPa).

Name		Main Function	
LED display		Displays monitor values for pressure, flow rate, etc., and the set values for each function. In the regular mode, it displays the current pressure.	
MODE key			Used to select the regular mode or monitor mode.
Setting keys	DOWN key		Used to select monitor data, select parameter numbers and set parameter values. The UP key increments the value and the DOWN key decrements the value.
	UP key		
ENT key			Used to confirm selections for parameter numbers, parameter settings, etc.

11.2 Functions of the Operation Panel

11.2.1 Function overview

The operation panel has the following functions.

Mode	Details
Regular mode	Displays the current pressure. The unit at shipment is MPa.
Monitor mode	Enables checking of the pressure, command voltage and current value of the flow rate, etc.
Setting mode	Enables setting of the various parameters.
Alarm mode	Enables checking of the previous 10 alarms.

11.2.2 Switching Among Modes

Switch among the modes as shown in the figure below. For details on the operations, refer to the explanations of each mode.

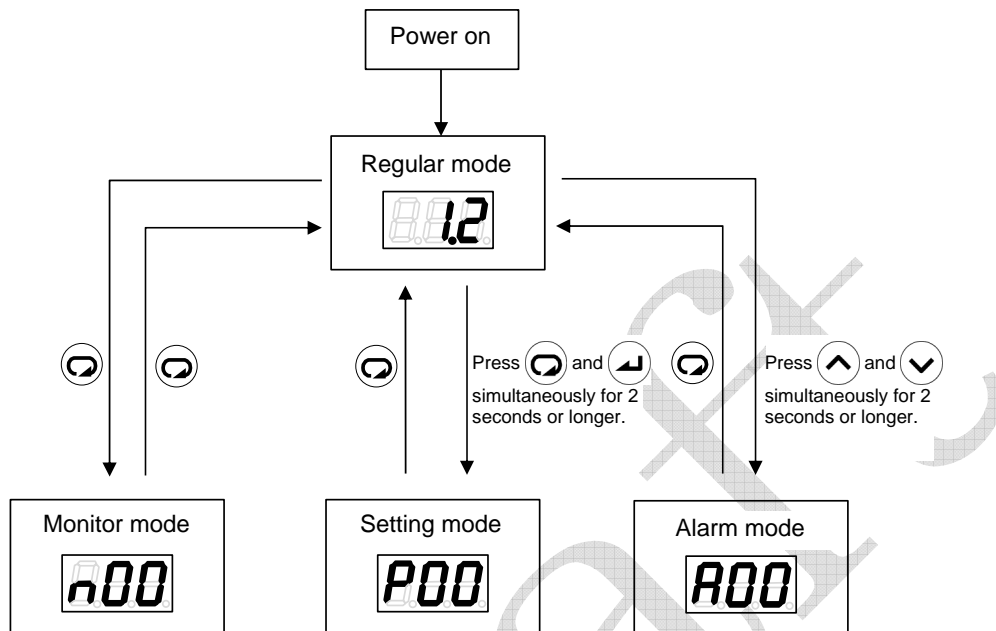

11.3 Regular Mode

In the regular mode, the display is as follows depending on the status at the time.

Status	Panel Indication	Description
Powering on	8.8.8.	At powering on, all the LEDs flash momentarily.
Normal	7.0	In the normal status, the current pressure is displayed.
Stopped	StP	Displayed when a stop command is in effect, and when the pressure is 0.15 MPa or lower.
AC failure	ACF	This is displayed flashing in the event of an AC failure (status where the power supply is shut off while charging the unit).
Occurrence of an alarm/warning	E17	When an alarm/warning occurs, the corresponding alarm code or warning code is displayed.

11.4 Monitor Mode

11.4.1 List of display items in the monitor mode

The monitor mode enables monitoring of the items listed in the table below by selection.

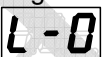
No.	Name	Unit	Details
n00	Pressure switch set value	MPa	Displays the value set with the pressure switch.
		×10 PSI	
n01	Pressure set value	MPa	Displays the current set value for pressure.
		×10 PSI	
n02	Flow rate set value	L/min	Displays the current set value for flow rate.
n03	Flow rate	L/min	Displays the current flow rate.
n04	Latest alarm code	-	Displays the alarm code for the alarm that occurred immediately previously. By pressing the  key, the current power-up count can also be checked.
n05	Motor rotation speed	×10 min ⁻¹	Displays the current rotational speed of the motor.
n06	Running status display	-	Displays the running status of the pump. While the pump is running, the segment dots repeatedly cycle from left to right. Example:  PQ selection No. 0
n07	(Reserved for the system)	-	This is reserved for the system.
n08	(Reserved for the system)	-	This is reserved for the system.
n09	(Reserved for the system)	-	This is reserved for the system.
n10	Motor temperature	°C	Displays the motor temperature.
n11	Radiating fin temperature	°C	Displays the temperature of the radiating fins.
n12	Main circuit DC voltage	V	Displays the direct current voltage of the controller's main circuit. The voltage value is the supply power voltage multiplied by the square root of 2, and it varies depending on the running status.
n13	(Reserved for the system)	-	This is reserved for the system.
n14	(Reserved for the system)	-	This is reserved for the system.
n15	(Reserved for the system)	-	This is reserved for the system.
n16	(Reserved for the system)	-	This is reserved for the system.
n17	(Reserved for the system)	-	This is reserved for the system.
n18	(Reserved for the system)	-	This is reserved for the system.
n19	(Reserved for the system)	-	This is reserved for the system.
n20	Power-on count (lower digits)	Times	Displays the number of times the unit has been powered on after shipment from the factory. (On exceeding a count of 9,999, the value is cleared to 0.)
n21	Power-on count (upper digits)	×1,000 times	
n22	Total operation time (minutes)	min	Displays the total operation time after shipment from the factory (time the motor is energized).
n23	Total operation time (hours)	h	
n24	Total operation time (thousands of hours)	×1,000 h	





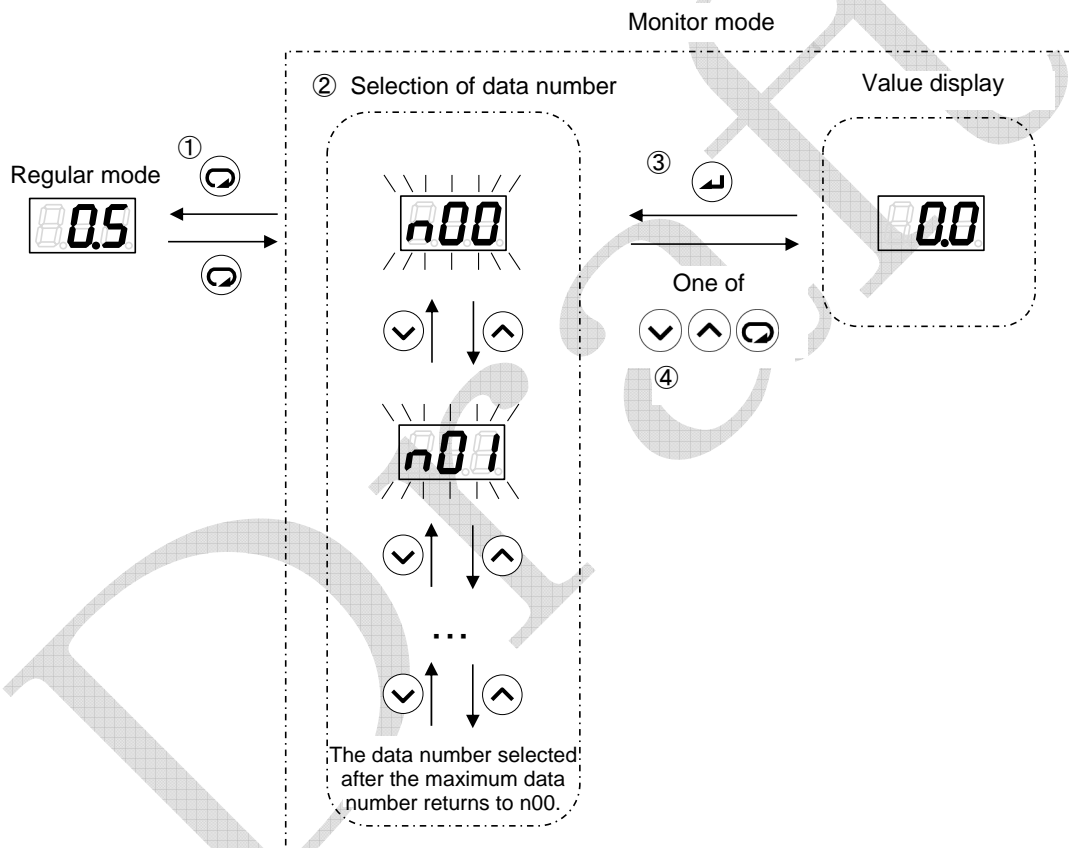

No.	Name	Unit	Details
n25	Power consumption	kW	Displays the current approximate power consumption.
n26	I/F board temperature	°C	Displays the current approximate temperature in the controller.
n27	(Reserved for the system)	-	Displays “-99”.

By pressing the  key while an alarm code is displayed, the current power-up count can be checked.

Memo	When the power-up count displayed for “n04 : Latest alarm code” exceeds 999, it is cleared to 0.
------	--

11.4.2 Monitor mode operations



- ① Press the  key in the regular mode. The mode will switch to the monitor mode.
- ② Select the data number to be displayed by using the  key or  key. During data number selection, the display will flash.
- ③ Confirm the data number by pressing the  key. The value for the selected data number will be displayed.
- ④ Return to data number selection with , , or .

11.5 Setting Mode

For details of parameters relating to the setting mode, refer to “Chapter 12 ADJUSTING PARAMETERS”.

11.5.1 Setting mode operations

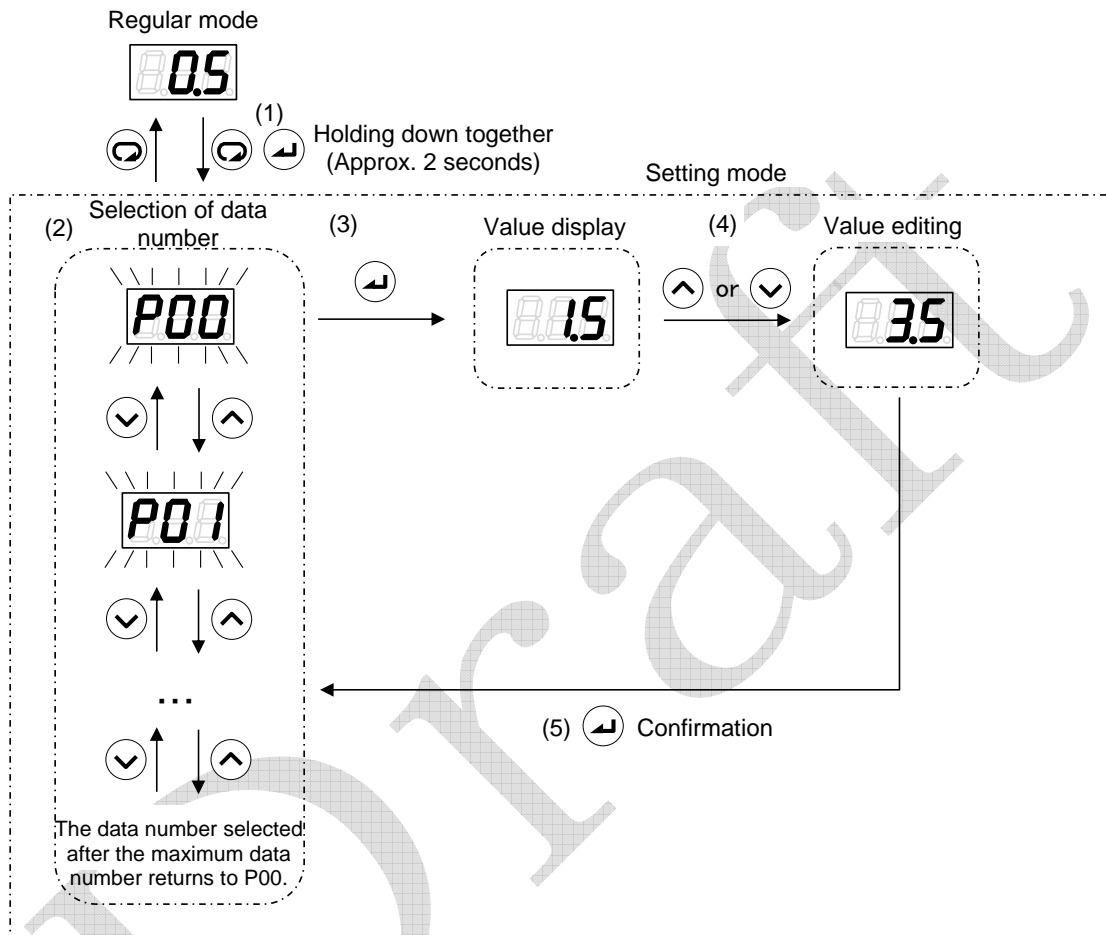

- (1) Hold down the and keys together in the regular mode. After about 2 seconds, the mode will switch to the setting mode.
- (2) Select the data number to be displayed by using the key or key. During data number selection, the display will flash.
- (3) Confirm the data number by pressing the key. The value for the selected data number will be displayed.
- (4) Change the set value by incrementing or decrementing it with the and keys.
- (5) Confirm the set value and return to data number selection by pressing the key.

■ PQ selection parameters

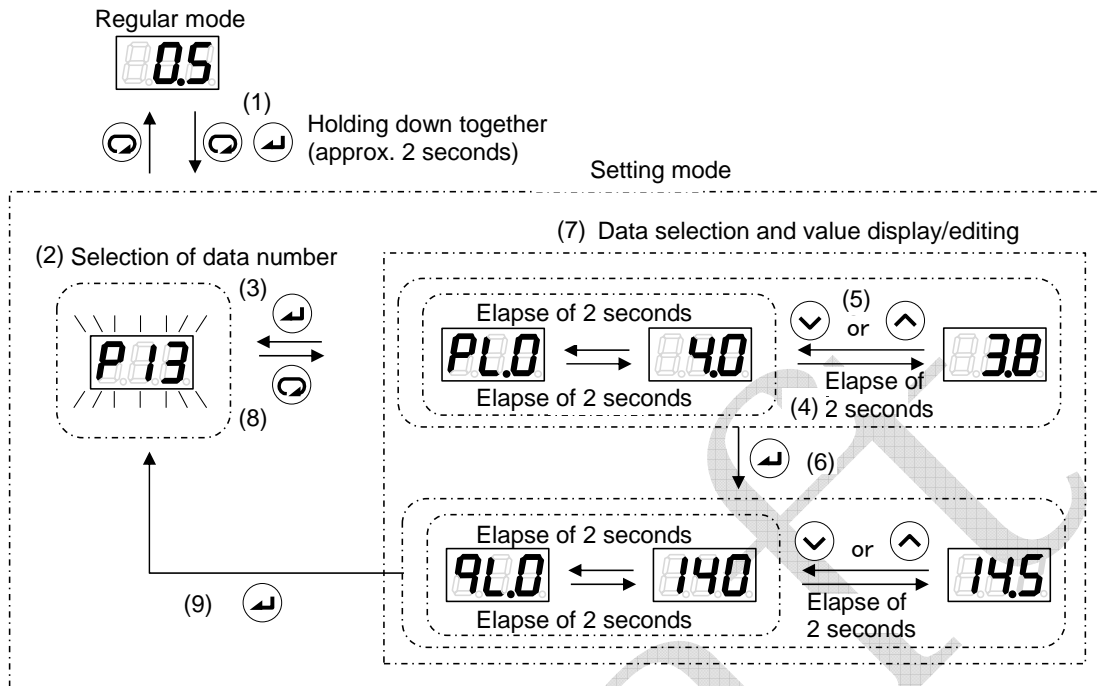

- (1) Hold down the and keys together in the regular mode. After about 2 seconds, the mode will switch to the setting mode.
- (2) Select P13 with the or key. During data number selection, the display will flash.
- (3) Confirm the data number by pressing the key. The value for the selected data number will be displayed.
- (4) The set values for pressure and flow rate in the PQ selection parameters will be displayed alternately at approximately 2-second intervals.
- (5) Change the set values by incrementing or decrementing them with the and keys. The data code will be displayed approximately 2 seconds after a set value has been changed.
- (6) Confirm the set value with the key. The next data code will be displayed.
- (7) Repeat steps (4), (5) and (6).
- (8) Pressing the key will switch the display to the data number selection screen. Parameters whose values have been changed up until that time will retain the changed values.
- (9) Setting the flow rate setting “qL.0” will switch the display to the data number selection screen.

■ Relationship between data display and parameters

Display Order	Display *1	Parameter Name
1		Pressure setting
2		Flow rate setting

11.6 Alarm Mode Display

The alarm mode enables checking of up to 10 alarms in the history of alarms that have occurred in the past. For details on the displayed alarm codes and their meanings, refer to “13.1 Alarm Causes and Corrective Actions”.

11.6.1 Alarm mode operations

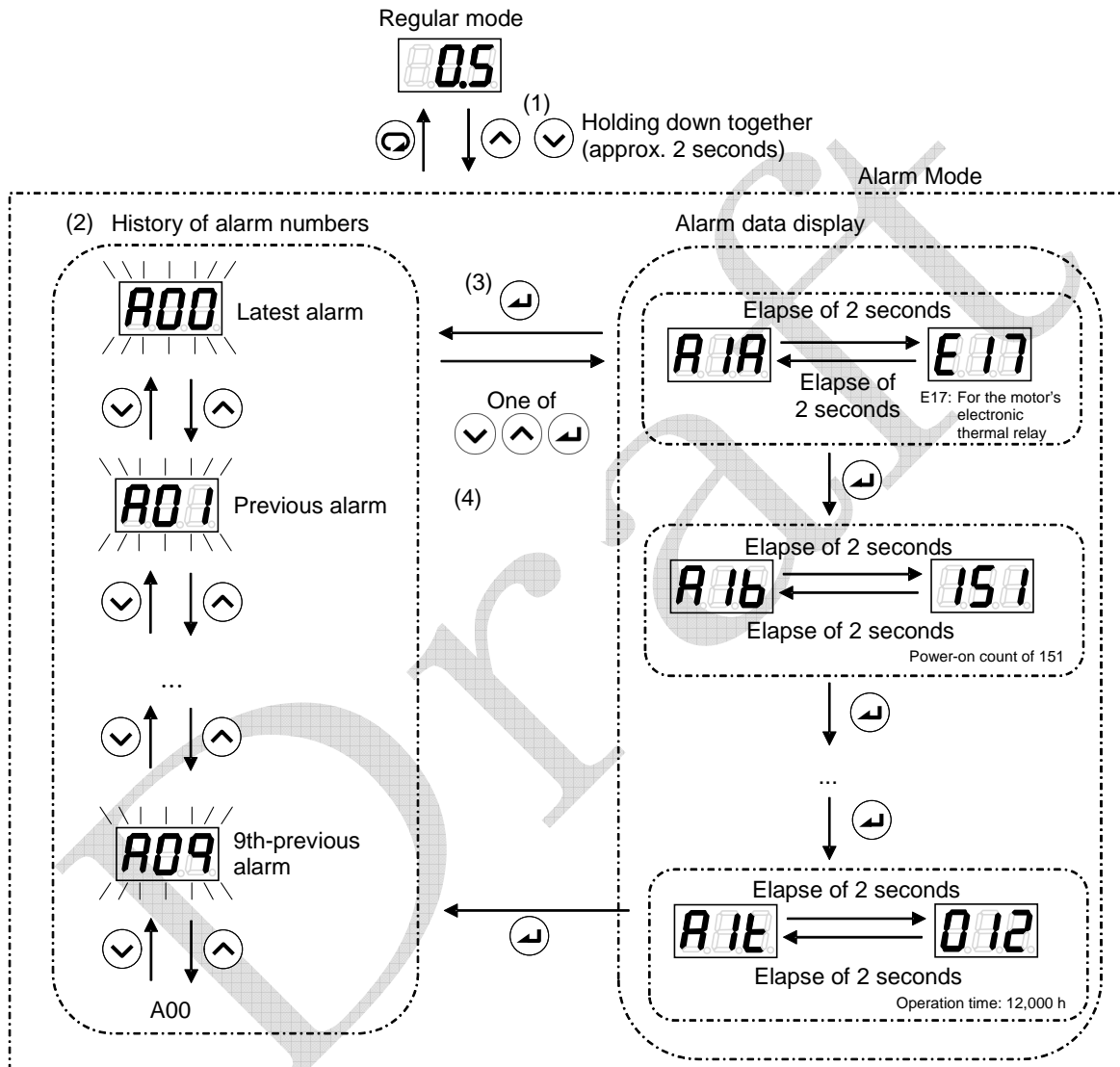

- (1) Hold down the and keys together in the regular mode. After about 2 seconds, the mode will switch to the alarm mode.
- (2) Select the alarm history number to be displayed by using the key or key. During alarm history number selection, the display will flash. A00 is the latest alarm, with older alarm displayed in sequence in this order: A01 → A02 → ...
- (3) Confirm the alarm history number with the key. The corresponding alarm code and the following data upon occurrence of the alarm concerned will be displayed alternately.
- (4) Return to the alarm history number selection by pressing the , or key.

No	Panel indication	Display	Display Unit	Remarks
1	A*A	Alarm details	-	Alarm details (See "13.1")
2	A*b	Power-on count	Number of times	Power-on count at occurrence of the alarm
3	A*r	Motor speed at alarm occurrence	10 min ⁻¹	Rotational speed of the motor at occurrence of the alarm
4	A*E	Effective motor current value	Arms	Effective current value of the motor at occurrence of the alarm
5	A*u	DC link voltage	V	DC link voltage at occurrence of the alarm
6	A*c	Radiating fin temperature	0.1°C	Radiating fin temperature at occurrence of the alarm
7	A*L	(Reserved for the system)	%	
8	A*F	(Reserved for the system)	%	
9	A*h	Operation time (minutes)	min	Operation time at occurrence of the alarm
10	A*H	Operation time (hours)	h	
11	A*t	Operation time (thousands of hours)	1000 h	

* "*" represents a numeric value from 0 to 9 indicating the alarm history.

Memo	<ul style="list-style-type: none"> • When the power-on count exceeds 999, it is cleared to 0. • When the rotational speed at occurrence is a negative value, three dots light.
------	--

Chapter 12. ADJUSTING PARAMETERS

12.1 Parameter List

Item	Code	Name	Operation range	Default Value	Details	Reference												
P00	DI_A	ON/OFF signal switching	0: Runs at DIN1-ON, 1: Runs at DIN1-OFF	1	DIN1: Sets the effective logic for the ON/OFF signal.	12.2												
P01	SW_L	Pressure switch	0 - 35.0 [MPa]	0	Sets the actuation value of the pressure switch. If set to "0", the pressure switch function is disabled.	12.5												
			0 - 507 [×10 PSI]	0														
P02	T_SW	Pressure switch output delay time	0.00 - 9.99 [sec]	0.00	Sets the delay time from when the pressure falls below the set value for "P01: Pressure switch" to confirmation of the pressure drop.	12.5												
P03	PSWH	Pressure switch indication retention setting	0 - 2	0	<p>When the "L63: Pressure switch actuation" warning has occurred, the "L63" indication displayed on the operation panel can be retained. It is also possible to record the "L63: Pressure switch actuation" warning in the alarm history, although it is not usually recorded there.</p> <table border="1"> <thead> <tr> <th>Value</th> <th>L63 Indication Retention</th> <th>Recording in Alarm History</th> </tr> </thead> <tbody> <tr> <td>0</td> <td>Not retained</td> <td>No recorded</td> </tr> <tr> <td>1</td> <td>Retained</td> <td>No recorded</td> </tr> <tr> <td>2</td> <td>Retained</td> <td>Recorded</td> </tr> </tbody> </table>	Value	L63 Indication Retention	Recording in Alarm History	0	Not retained	No recorded	1	Retained	No recorded	2	Retained	Recorded	12.5
						Value	L63 Indication Retention	Recording in Alarm History										
						0	Not retained	No recorded										
						1	Retained	No recorded										
2	Retained	Recorded																
P04	DS_P	Pressure unit selection setting*	0: MPa indication 1: PSI indication	0	Enables selection of the display unit for pressures displayed on the panel.	-												
P05	K_RT	(Reserved for the system)	-	-	This is reserved for the system.	-												
P06	D_RT	(Reserved for the system)	-	-	This is reserved for the system.	-												
P07	WN_M	(Reserved for the system)	-	-	This is reserved for the system.	-												
P08	AMIX	(Reserved for the system)	-	-	This is reserved for the system.	-												
P09	INIF	Initialize to defaults	0: Disable 1: Initialize P00 to P09 2: Initialize all parameters	0	Setting "1" or "2" then turning the power off and back on initializes parameters to their default values according to the setting made.	-												

Item	Code	Name	Operation range		Default Value	Details	Reference
P10	L_TI	PQ integration time correction factor	1 - 500 [%]		100	Sets the integration time correction factor for PQ control. The smaller the value, the faster the response, but the more surge pressure occurs.	-
P11	M_VR	(Reserved for the system)	-		-	This is reserved for the system.	-
P12	W_TM	(Reserved for the system)	-		-	This is reserved for the system.	-
P13	PL.0	Pressure setting	4 MPa specifications	1.5 - 4.0 [MPa]	1.5	Sets the target pressure.	12.3
				22 - 58 [×10 PSI]	58		
			7 MPa specifications	1.5 - 7.0 [MPa]	1.5		
				22 - 101 [×10 PSI]	101		
	QL.0	Flow rate setting	14 L specifications	2.5 - 15.2 [L/min]	15.2		
			25 L specifications	3.5 - 25.1 [L/min]	25.0		
30 L specifications			3.5 - 28.5 [L/min]	28.5			
P14 - P28		(Reserved for the system)	-		-	This is reserved for the system.	-
P29	C_TM	(Reserved for the system)	-		-	This is reserved for the system.	-
P30	DF_N	(Reserved for the system)	-		-	This is reserved for the system.	-
P31	P_SN	Pressure sensor rated value	1 - 35 [MPa]		10	Sets the rated pressure of the pressure sensor. Normally, this setting does not need to be changed.	-
P32	S_TM	Surgeless start time	0.01 - 9.99 [sec]		0.50	Sets the start-up time for a start with the motor at a stop. Increasing the value makes the start-up smoother and can prevent start-up surge, but it lengthens the response time at start-up.	12.7.2
P33	L_IN	(Reserved for the system)	-		-	This is reserved for the system.	-
P34	E_TM	(Reserved for the system)	-		-	This is reserved for the system.	-
P35	DR_L	Dry operation judgment pressure	0.00 - 2.00 [MPa]		0.50	Sets the pressure condition for judging "E64: Dry operation error".	12.6.1
			0 - 290 [PSI]		72		
P36	DR_T	Dry operation judgment time	0.01 - 9.99 [sec]		3.00	Sets the time for judging "E64: Dry operation error".	12.6.1

Item	Code	Name	Operation range	Default Value	Details	Reference
P37	SM_R	(Reserved for the system)	-	-	This is reserved for the system.	-
P38	P_DF	Pressure switch output dead zone	0.00 - 1.00 [MPa]	0.50	Sets the threshold value for detecting pressure recovery, after actuation of the pressure switch. This is set as a difference in the positive direction in relation to "P01: Pressure switch".	12.5
			0 - 145 [PSI]	72		
P39	DO_S	Digital output selection	0 - 15	8	Sets the content of signals output from digital outputs and alarm outputs.	12.4
P40	PL_D	(Reserved for the system)	-	-	This is reserved for the system.	-
P41	PCMW	(Reserved for the system)	-	-	This is reserved for the system.	-
P42	PCMM	(Reserved for the system)	-	-	This is reserved for the system.	-
P43	QCMW	(Reserved for the system)	-	-	This is reserved for the system.	-
P44	QCMM	(Reserved for the system)	-	-	This is reserved for the system.	-
P45	AC_F	Cooling fan motor speed	0: Always running (low speed) 1: Reserved for the system 2: Always running (high speed)	0	Switches the operation speed of the cooling fan.	12.7.1
P46	TVMJ	Maintenance implementation review enable/disable	0: Maintenance implementation review disabled 1: Maintenance implementation review enabled	0	Selects whether or not to issue an E66 (motor temperature rise due to pressure holding speed drop) alarm on occurrence of an L67 (pressure holding speed drop) warning while "H52: TVMR Maintenance request" is set to 1.	12.6
P47	RMOT	Alarm relay output maintenance notification enable/disable	0: Repetition of alarm relay ON/OFF upon occurrence of an L67 or E66 disabled 1: Repetition of alarm relay ON/OFF upon occurrence of an L67 or E66 enabled	0	Selects whether or not to repeat alarm relay ON/OFF on occurrence of an L67 (pressure holding speed drop) warning or an E66 (motor temperature rise due to pressure holding speed drop) alarm. (The value of P39 is also taken into account to determine whether or not to repeat ON/OFF upon occurrence of an L67.)	12.4
P48	T_SP	Reverse rotation warning judgment time	0.0 - 99.9 [sec]	0.5	Sets the judgment time for detection of the reverse rotation warning (L70).	12.7.3
P49	SWTM	Start acceptance wait time	0.0 - 99.9 [sec]	0	Sets the time from receiving a start command to actually initiating the start.	12.7.3

Item	Code	Name	Operation range	Default Value	Details	Reference
P50	OTUS	(Reserved for the system)	-	-	This is reserved for the system.	-
P51	OTAM	(Reserved for the system)	-	-	This is reserved for the system.	-
P52	OTAT	(Reserved for the system)	-	-	This is reserved for the system.	-
P53	OTWN	(Reserved for the system)	-	-	This is reserved for the system.	-
P54	OTWT	(Reserved for the system)	-	-	This is reserved for the system.	-
P55	WN_L	Motor electronic thermal relay overload warning threshold value	101 - 109 [%]	105	Sets the threshold value for the motor electronic thermal relay overload warning.	12.6.3

Flow rate indications are displayed as shown below.

Flow Rate in the Setting Mode	Display Details
Edited value	.5 rounded up, .4 rounded down
Maximum value	Rounded down
Minimum value	Truncation + 0.1 L/min

▲ CAUTION

The “P04: Pressure unit selection setting” is set to indication in MPa units as the factory default. If it has been changed to indication in PSI units, implement some measure to make it apparent that it is in PSI units, such as affixing an indication sticker. Prepare this sticker yourself. Note, however, that using the unit in PSI units in Japan is an infringement of the Measurement Act.

12.2 [P00: DI_A] Switching the Effective Logic for the ON/OFF Signal

The motor can be run and stopped by input signals at digital input terminal DIN1.
This parameter enables switching of the effective logic of digital input terminal DIN1.

No.	Code	Name	Setting range	Default value	Unit
P00	DI_A	ON/OFF signal switching	0: Pump runs when DIN1 is ON 1: Pump runs when DIN1 is OFF	1	-

Set value	DIN1 terminal status	
	OFF	ON
0	Pump stop	Pump start
1	Pump start	Pump stop

▲ CAUTION

Frequent starts and stops by turning the power ON/OFF will cause damage the controller.
Starting and stopping the pump other than in emergencies should be accomplished by turning digital input terminal DIN1 ON and OFF..

Memo When using the product without using the ON/OFF digital input signals, setting "1" for this parameter causes the hydraulic unit to start automatically in response to powering up.

12.3 [P13: PL0/QL0] Pressure/Flow Rate Characteristics and Settings

Set the pressure set value for PL0 and the flow rate set value for QL0.

Display	Code	Parameter Name	Setting range	Default value	Unit
P13	PL0	Pressure setting	4 MPa specifications: 1.5 to 4.0	1.5	MPa
			7 MPa specifications: 1.5 to 7.0	1.5	
	QL0	Flow rate setting	14 L specifications: 2.5 to 15.2	15.2	L/min
			25 L specifications: 3.5 to 25.1	25.1	
			30 L specifications: 3.5 to 28.5	28.5	

The pressure/flow rate characteristic curve is shown below.

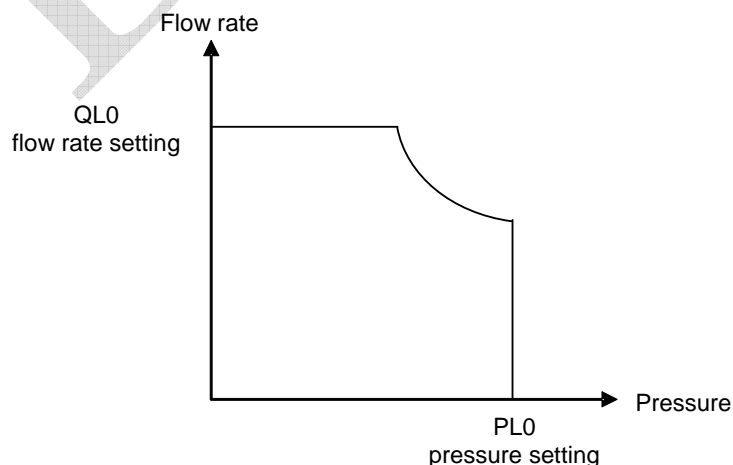

12.4 Setting Output Signals

The signals output as the result of alarm outputs operate as described in the tables below according to the values set for “P39: DO_S Digital output selection” and “P47: RMOT Alarm relay output maintenance notification enable/disable”.

12.4.1 Parameters

■ Parameters relating to output signals

Display	Code	Parameter Name	Setting range	Default value	Unit
P39	DO_S	Digital output selection	0 - 15	8	-
P47	RMOT	Alarm relay output maintenance notification enable/disable	0 - 1	0	-

12.4.2 [P39: DO_S] Digital output selection/[P47: RMOT] Alarm relay output maintenance notification enable/disable

The signals output as the result of alarm outputs operate as described in the tables below according to the values set for “P39: DO_S Digital output selection” and “P47: RMOT Alarm relay output maintenance notification enable/disable”.

■ Operation of alarm output signals

P39: DO_S Digital output selection	P47: RMOT Alarm relay output maintenance notification enable/disable	Operation
0-7	-	-
8-10,12	0	<ul style="list-style-type: none"> • Open at alarm occurrence or at hydraulic switch actuation
	1	<ul style="list-style-type: none"> • Open at alarm occurrence or at hydraulic switch actuation • When an E66 alarm occurs, ON/OFF repeated for 10 minutes
11	0	<ul style="list-style-type: none"> • Open at alarm occurrence or at hydraulic switch actuation
	1	<ul style="list-style-type: none"> • Open at alarm occurrence or at hydraulic switch actuation • When an E66 alarm or L67 warning occurs, ON/OFF repeated for 10 minutes

The signals output from digital outputs operate as described in the table below according to the value set for “P39: Digital output selection”.

■ Operation of the DOUT digital output signal

P39: DO_S Digital output selection	Name	Operation
0-7	(Reserved for the system)	-
8	Disabled (ready to run signal used)	Comes ON when ready to run
9	Open at occurrence (combined use with ready to run signal)	Goes OFF on occurrence of a warning
10	Closed at occurrence (ready to run signal not used)	Comes ON on occurrence of a warning
11	Used in combination with alarm (ready to run signal used)	Comes ON when ready to run
12	The logical inverse of selection 8	Goes OFF when ready to run

12.5 Pressure Switch

The pressure switch is a function for detecting when the pressure drops below a certain level and outputting a signal. Using this function makes an externally fitted pressure switch unnecessary, making it possible to configure systems inexpensively. The pressure switch is set as follows.

12.5.1 Parameter list

No.	Code	Parameter Name	Setting range	Default value	Unit
P01	SW_L	Pressure switch actuation level	0 to 35.0 (0: Function disabled)	0.0	MPa
			0 to 507 (0: Function disabled)	0.0	×10 PSI
P02	T_SW	Pressure switch output delay time	0.00 - 9.99	0.00	sec
P03	PSWH	Pressure switch indication retention	0: Disabled 1: Indication retained 2: Display and record	0	-
P38	P_DF	Pressure switch output dead zone	0.00 - 1.00	0.50	MPa
			0 - 145	72	PSI

12.5.2 Explanation of parameters

Setting	Parameters		Function												
	No.	Name													
Panel indication	P03	Pressure switch indication retention	<p>When the “L63: Pressure switch actuation” warning has occurred, the “L63” indication displayed on the operation panel can be retained.</p> <p>It is also possible to record the “L63: Pressure switch actuation” warning in the alarm history, although it is not usually recorded there.</p> <table border="1"> <thead> <tr> <th>Value</th> <th>L63 Indication Retention</th> <th>Recording in Alarm History</th> </tr> </thead> <tbody> <tr> <td>0</td> <td>Not retained</td> <td>No recorded</td> </tr> <tr> <td>1</td> <td>Retained</td> <td>No recorded</td> </tr> <tr> <td>2</td> <td>Retained</td> <td>Recorded</td> </tr> </tbody> </table> <p>When L63 indication retention is set to “Retain”, the “L63: Pressure switch actuation” indication is retained even when the pressure recovers after detection of a pressure drop.</p> <p>Pressing the  key clears the indication.</p>	Value	L63 Indication Retention	Recording in Alarm History	0	Not retained	No recorded	1	Retained	No recorded	2	Retained	Recorded
			Value	L63 Indication Retention	Recording in Alarm History										
0	Not retained	No recorded													
1	Retained	No recorded													
2	Retained	Recorded													
Pressure drop detection	P01	Pressure switch actuation level	Sets the actuation value of the pressure switch. Setting the value to 0 disables the pressure switch function.												
	P02	Pressure switch output delay time	This is the delay time between the pressure dropping below “P01: Pressure switch actuation level” and the pressure drop being confirmed.												
Pressure recovery detection	P38	Pressure switch output dead zone setting	Sets the pressure level recognized as recovery from the pressure drop status as a difference in the positive direction with respect to “P01: Pressure switch actuation level”.												

■ Example of pressure switch actuation:

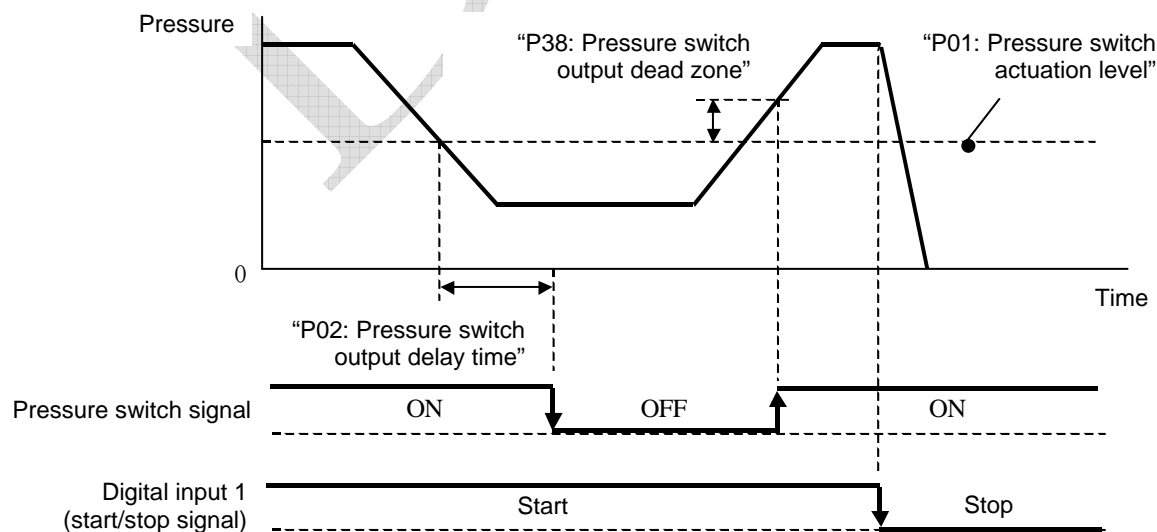

12.6 Settings Relating to Warnings/Alarms

12.6.1 Setting judgment criteria for [E64: Dry running error]

Pressure rise faults resulting from inclusion of air due to a drop in the oil level, or from a drop in viscosity due to inclusion of water, are detected and the unit is stopped by the “E64: Dry running error” alarm to prevent damage to the pump. When the pressure and flow rate remain in the dry running area in the figure below for the time set for “P36: Dry running judgment time”, “E64: Dry running error” is detected.

◆ Dry running detection area

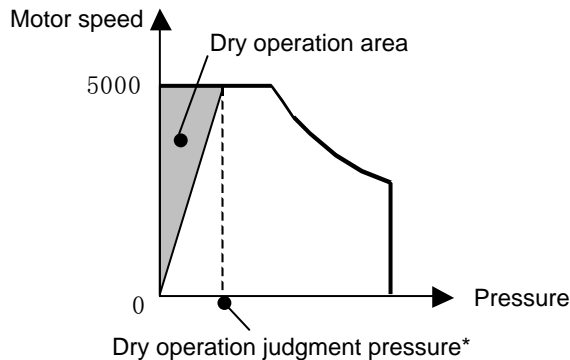

* The value set for “P35: Dry operation judgment pressure” is used as the dry operation judgment pressure.

12.6.2 Setting related to [E66: Temperature error due to pressure holding rotation speed drop]

Display	Code	Parameter Name	Setting range	Default value	Unit
P46	TVMJ	Maintenance implementation review enable/disable	0: Maintenance implementation review disabled, 1: Maintenance implementation review enabled	0	-

An “E66: Temperature error due to pressure holding rotation speed drop” alarm occurs when either of the following two conditions have been satisfied.

- (1) The conditions for occurrence of the E41 alarm (Abnormal motor temperature rise) have been established while an L67 warning (Holding pressure speed drop) is in effect.
- (2) When 1 is set for parameter “P46: TVMJ Maintenance implementation enable/disable”, an E41 alarm (Abnormal motor temperature rise) occurs after an L67 warning (Holding pressure rotation speed drop), and the L67 warning is detected again after turning the power OFF and back ON.

12.6.3 Setting related to [L49: Motor electronic thermal relay overload warning]

Display	Code	Parameter Name	Setting range	Default value	Unit
P55	WN_L	Motor electronic thermal relay overload warning threshold value	101 - 109	105	%

When the motor current mean load factor reaches or exceeds the value set for WN_L, “L49: Motor electronic thermal relay overload warning” is judged to have occurred.

12.7 Others

12.7.1 [P45: AC_F] Cooling fan motor speed

This sets the speed of the cooling fan motor.

Display	Code	Parameter Name	Setting range	Default value	Unit
P45	AC_F	Cooling fan motor speed	0: Always running (low speed) 1: Reserved by the system 2: Always running (high speed)	0	-

12.7.2 [P32: S_TM] Surge suppression at starts

When starting from the stopped state, the deviation is large, which increases the likelihood of surge pressure. For this reason, pressure commands and flow rate commands are increased with a fixed gradient to suppress the generation of surge pressure.

Display	Code	Parameter Name	Setting range	Default value	Unit
P32	S_TM	Surgeless start time	0.01 to 9.99	0.5	sec

■ Change in command value at start

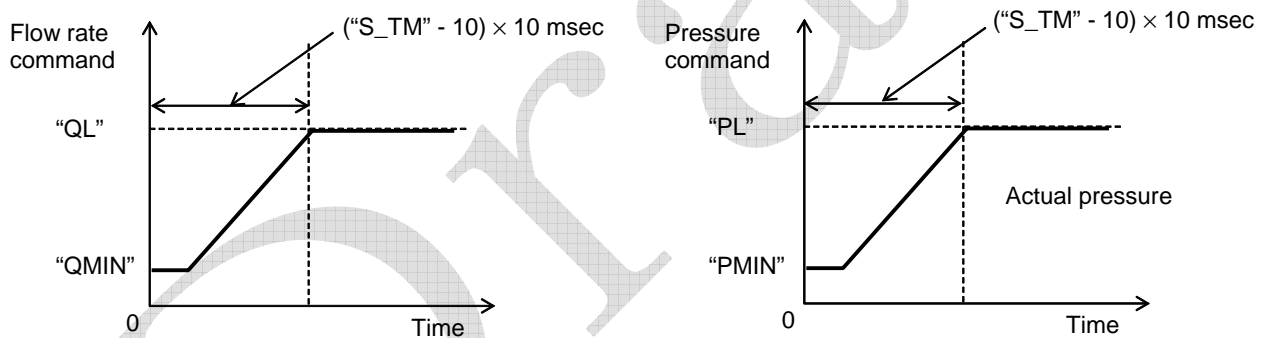

Note that the gradient of the command value can be adjusted with "S_TM", but that the gradient is subject to restriction internally in the controller due to constraints on the response characteristics of the motor control.

12.7.3 [P48 : T_SP] Reverse rotation warning judgment wait time/[P49: SMTM] Start acceptance wait time

No.	Code	Name	Setting range	Default value	Unit
P48	T_SP	Reverse rotation warning judgment wait time	0 - 99.9	0.5	sec
P49	SWTM	Start acceptance wait time	0 - 99.9	0	sec

If the motor rotates in reverse during stop operation and is restarted with load pressure remaining in the piping at the start, it is possible that the start will fail. For this reason, if the motor is rotating in reverse a reverse rotation warning status is judged, and the start of motor excitation can be automatically delayed by setting [P48 : T_SP] "Reverse rotation warning judgment wait time".

Note also that when the volume of the piping is large, by setting [P49:SWTM] "Start acceptance wait time" as an adjustment when there is residual pressure in the piping, even when the pressure detected by the pressure sensor is less than the pressure for judging a reverse rotation warning, the motor start can be delayed beyond the reverse rotation warning judgment wait time end point, or the point when the reverse rotation warning is canceled.

The time charts when a reverse rotation warning has been issued and when none has been issued are presented below.

■ Time chart for a start when no reverse rotation warning has been issued

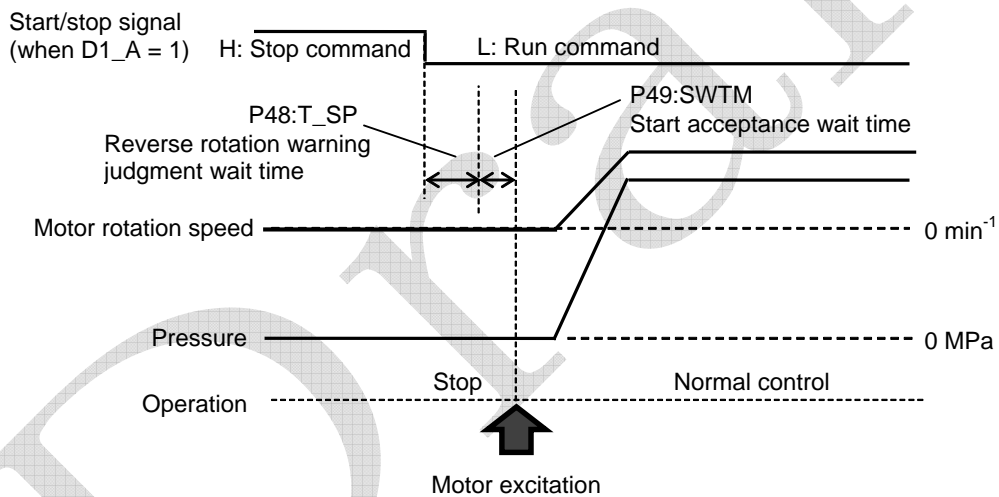

■ Time chart for a start when a reverse rotation warning has been issued

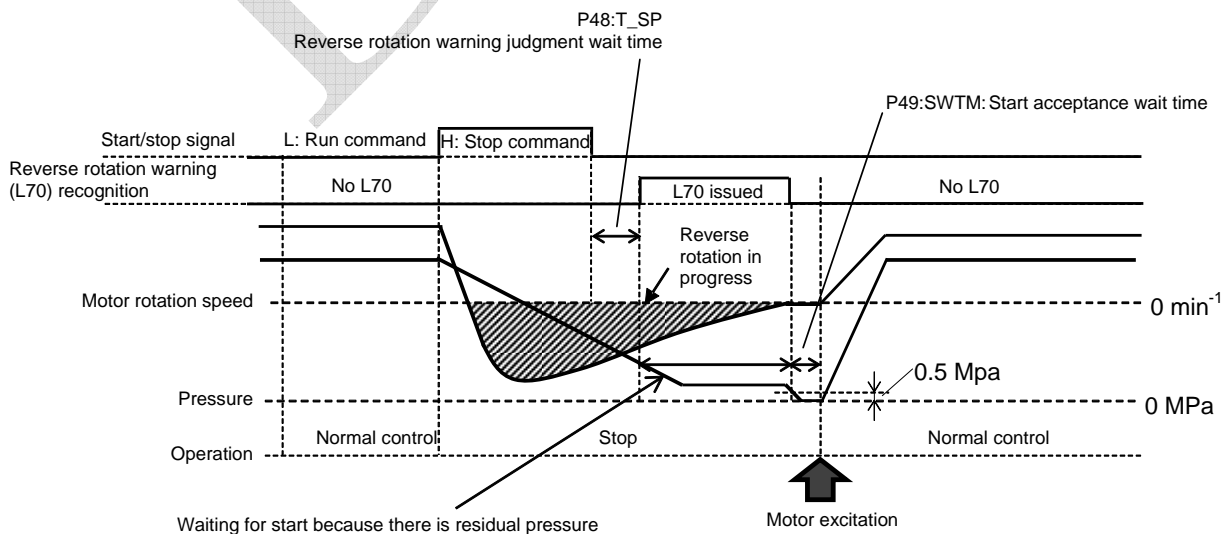

Chapter 13. TROUBLESHOOTING

13.1 Alarm Causes and Corrective Actions

Alarm Code	Name	Cause	Corrective Action
E10	Output device error The protective function of the output device has been actuated.	Short circuit of the device output	Check the connection.
		Motor control error	<ul style="list-style-type: none"> Adjust the relief valve setting to the running pressure + 0.5 MPa. If there is a large hydraulic load due to deterioration of the oil, change the oil.
		Controller failure	Replace the controller.
		Motor coil short circuit	Replace the motor or motor pump.
		Cooling fan system failure	<ul style="list-style-type: none"> Replace the cooling fan. Replace the fuse.
E11	Overcurrent Overcurrent protection by the software has been actuated.	Short circuit of the device output	Check the connection.
		Motor control error	Same as E10
		Controller failure	Replace the controller.
		Motor coil short circuit	Replace the motor or motor pump.
E12	Overspeed The motor speed has exceeded 120% of the maximum speed.	Overshoot due to sudden acceleration	Adjust the control gain to moderate the acceleration/deceleration response.
		Motor control error	Same as E10
E15	Insufficient voltage The main circuit voltage has dropped.	Controller failure	Replace the controller.
		Low power supply voltage	Check the power supply voltage in the monitor mode [n12: Main circuit voltage], and bring the voltage within the stipulation.
E16	Overvoltage The main circuit voltage became excessive.	Controller failure	Replace the controller.
		High power supply voltage	Check the power supply voltage in the monitor mode [n12: Main circuit voltage], and bring the voltage within the stipulation.
E17	Motor electronic thermal relay error Overload protection triggered by the electronic thermal relay has been actuated.	The load torque is larger than usual due to wear of the pump, for example.	Replace the pump or motor pump.
		The motor magnets have demagnetized and the current has increased.	Replace the motor or motor pump.

Alarm Code	Name	Cause	Corrective Action
E21	Motor wiring disconnection One phase of the motor wiring is not live.	Motor wiring disconnection, connection fault	<ul style="list-style-type: none"> • Reconnect and check the connection. • Replace the motor or motor pump.
		Output device failure	Replace the controller.
		Connector fault at controller	
E22	Inverter PCB internal error	Controller failure	Replace the controller.
E23	Current sensor error There is an error in the current detection section and detection is not possible.	Motor wiring disconnection, connection fault	<ul style="list-style-type: none"> • Reconnect and check the connection. • Replace the motor or motor pump.
		Output device failure	Replace the controller.
		Connector fault at controller	
E24	Open phase in power supply One phase in the input power supply is not live.	Disconnection of the power supply cable	<ul style="list-style-type: none"> • Check the power supply wiring. • If there is a disconnection in the wiring, replace it.
		Deterioration of the power supply environment	Improve the power supply environment.
		Power supply cable internal harness connection fault, disconnection	Replace the controller.
E25	Voltage sensor error There is an error in the voltage detection section and voltage detection is not possible.	Controller failure	Replace the controller.
E26	Motor control error Motor control fault	Set value for the high-pressure safety valve is too high	Adjust the setting of the high-pressure safety valve to the operation pressure + 0.5 MPa.
		Controller failure	Replace the controller.
E29	Motor start error The motor fails to transition to normal operation condition at starting.	Excessive load torque at starting due to increased oil viscosity	Replace the hydraulic oil.
		Excessive load torque at starting due to damage to the motor pump bearing	Replace the pump or motor pump.
E30	Pressure sensor system error The motor pressure sensor is disconnected or short circuited.	Pressure sensor connector is not connected	Connect the connector.
		Damaged pressure sensor harness	Replace the pressure sensor harness.
		Pressure sensor failure	Replace the pressure sensor.
		Controller failure	Replace the controller.

Alarm Code	Name	Cause	Corrective Action
E32	Motor lock error The motor does not rotate when started.	Pump seized	Replace the motor pump.
		Locked due to contamination	<ul style="list-style-type: none"> Restart again. Replace the hydraulic oil. Clean the suction strainer.
		Bearing seized	Replace the motor pump.
E40	Motor thermistor disconnection/short circuit The motor thermistor is disconnected or short circuited.	Motor thermistor wiring is disconnected or short circuited	Replace the thermistor.
		Controller failure	Replace the controller.
E41	Abnormal rise in motor temperature The motor temperature exceeded the stipulated value of 85°C for 30 seconds or longer.	The motor cooling fan has stopped.	<ul style="list-style-type: none"> Replace the fuse for the fan. Replace the cooling fan. Replace the fan harness. Replace the controller.
		The radiator is clogged.	Clean or replace the radiator.
		The motor rotation speed has risen.	<ul style="list-style-type: none"> Check if the amount of oil leaking from the circuit at the main machine has increased. Review the setting of the high-pressure safety valve. Replace the motor pump.
		The ambient temperature is too high.	<ul style="list-style-type: none"> Install the unit at a location where the ambient temperature is within the stipulation. Install the unit at a location with good ventilation.
		Controller failure	Replace the controller.
E42	Radiating fin thermistor disconnection The device thermistor is disconnected or short circuited.	Controller failure	Replace the controller.
E43	Abnormal temperature rise at a radiation fin The device temperature exceeded the stipulated value of 110°C for 1 second or longer.	The cooling fan has stopped.	<ul style="list-style-type: none"> Replace the fuse for the fan. Replace the cooling fan. Replace the controller.
		The radiator is clogged.	Clean or replace the radiator.
		The motor rotation speed has risen.	<ul style="list-style-type: none"> Check if the amount of oil leaking from the circuit at the main machine has increased. Review the setting of the high-pressure safety valve. Replace the motor pump.
		The ambient temperature is too high.	<ul style="list-style-type: none"> Install the unit at a location where the ambient temperature is within the stipulation. Install the unit at a location with good ventilation.
		Controller failure	Replace the controller.

Alarm Code	Name	Cause	Corrective Action
E46	PCB thermistor disconnection/short circuit The PCB thermistor is disconnected or short circuited.	Controller failure	Replace the controller.
E47	Abnormal temperature at PCB The PCB temperature has exceeded the stipulated value for 1 second or longer.	Controller failure	Replace the controller.
		The cooling fan has stopped.	Replace the fuse for the cooling fan. Replace the cooling fan. Replace the controller.
		The radiator is clogged.	Clean or replace the radiator.
		The ambient temperature is too high.	<ul style="list-style-type: none"> • Install the unit at a location where the ambient temperature is within the stipulation. • Install the unit at a location with good ventilation.
E64	Dry operation error The pump was started while the oil level was low.	The oil level is low.	Replenish the hydraulic oil.
		The motor is rotating in reverse.	Check the motor wiring and connect it correctly.
		Oil intake takes time.	<ul style="list-style-type: none"> • Change the values set for parameters "P35: Dry running judgment pressure" and "P36: Dry running judgment time".
E66	Temperature error due to pressure holding rotation speed drop	The throttle is clogged.	<ul style="list-style-type: none"> • Clean the high-pressure safety valve's throttle. • Adjust the throttle. • Replace the oil.
E90	Internal error The software cannot be initialized normally.	Faulty connection of communication harness between PCBs	Check the connection, and if there is a harness fault, replace the harness.
		Controller failure	Replace the controller.
		The software versions are inconsistent.	
E91	CPU out of control error A CPU WDT reset has occurred.	The software load has become excessive.	Turn the power off and back on.
E94	EEPROM data error The stored parameter settings are out of range.	EEPROM data error	Set the parameter causing the error to a value within the range.
E95	Software consistency error The software and hardware types do not match.	Hardware identification error	Replace the controller.
		Mismatch between PCB and model parameters	

Alarm Code	Name	Cause	Corrective Action
E96	Internal communication error After completion of initialization, internal communication was discontinued for the stipulated time or longer.	Controller internal communication error	Replace the controller.
		The CPU does not work.	
		Communication fault due to noise	
		Controller failure	

Draft

13.2 Warning Causes and Corrective Actions

Warning Code	Name	Cause	Corrective Action
L44	Motor abnormal temperature warning The motor temperature exceeded the stipulated value of 83°C for 10 seconds or longer.	The motor cooling fan has stopped.	<ul style="list-style-type: none"> • Replace the fuse for the fan. • Replace the cooling fan. • Replace the controller. • Replace the fan harness.
		The radiator is clogged.	<ul style="list-style-type: none"> • Clean or replace the radiator.
		The motor rotation speed has risen.	<ul style="list-style-type: none"> • Check if the amount of oil leaking from the circuit at the main machine has increased. • Review the setting of the high-pressure safety valve. • Replace the motor pump.
		The ambient temperature is too high.	<ul style="list-style-type: none"> • Install the unit at a location where the ambient temperature is within the stipulation. • Install the unit in a location with good ventilation.
L45	Abnormal temperature at radiation fin. The radiating fin temperature exceeded the stipulated value of 108°C for 10 seconds or longer.	The cooling fan has stopped.	<ul style="list-style-type: none"> • Replace the fuse for the fan. • Replace the cooling fan. • Replace the controller.
		The radiator is clogged.	<ul style="list-style-type: none"> • Clean or replace the radiator.
		The motor rotation speed has risen.	<ul style="list-style-type: none"> • Check if the amount of oil leaking from the circuit at the main machine has increased. • Review the setting of the high-pressure safety valve. • Replace the motor pump.
		The ambient temperature is too high.	<ul style="list-style-type: none"> • Install the unit at a location where the ambient temperature is within the stipulation. • Install the unit in a location with good ventilation.
L48	Abnormal temperature at PCB The PCB temperature exceeded the stipulated value of 68°C for 10 seconds or longer.	The cooling fan has stopped.	<ul style="list-style-type: none"> • Replace the fuse for the fan. • Replace the cooling fan. • Replace the controller.
		The radiator is clogged.	<ul style="list-style-type: none"> • Clean or replace the radiator.
		The motor speed has risen.	<ul style="list-style-type: none"> • Check if the amount of oil leaking from the circuit at the main machine has increased. • Review the setting of the high-pressure safety valve. • Replace the motor pump.
		The ambient temperature is too high.	<ul style="list-style-type: none"> • Install the unit at a location where the ambient temperature is within the stipulation. • Install the unit at a location with good ventilation.

Warning Code	Name	Cause	Corrective Action
L49	Motor electronic thermal relay overload	The load torque is larger than usual due to wear of the pump, for example.	Replace the pump or motor pump.
	Overload protection triggered by the electronic thermal relay has been actuated.	The motor magnets have demagnetized and the current has increased.	Replace the motor or motor pump.
L50	Power supply voltage drop The main circuit voltage value remained at under 254 V for 2 seconds.	The input power supply voltage is low.	Improve the power supply environment.
L53	Controller cooling fan rotation speed drop warning	The cooling fan has stopped.	<ul style="list-style-type: none"> • Replace the fuse for the fan. • Replace the cooling fan. • Replace the controller.
	The cooling fan speed has decreased to 80% or less of the normal speed for 10 seconds or longer.	Foreign matter or dirt has become entrapped in the cooling fan.	Clean or replace the cooling fan.
L63	Pressure switch actuation The pressure switch has been actuated.	The pressure reached the value set for parameter "P01: Pressure switch" or lower.	If there is nothing abnormal in the operation of the main machine, review the set value for the pressure switch or the delay time.
L67	Holding pressure rotation speed drop When target rotational speed = 300 min ⁻¹ , and the status where pressure value ≥ (set value + [H51: DHSL] L67: Holding pressure speed drop warning judgment pressure offset) has continued for 2 seconds.	The throttle is clogged.	<ul style="list-style-type: none"> • Clean the throttle of the high-pressure safety valve. • Adjust the throttle. • Replace the oil.
L70	Reverse rotation When the start command goes from OFF to ON and the pressure does not reach "H54: RT_O Reverse rotation warning judgment pressure" or higher even after "P48: T_SP Reverse rotation warning judgment wait time" or longer has elapsed.	A run command has been input immediately after a stop while the load was excessive.	<ul style="list-style-type: none"> • Increase the value of parameter P48. • Review the run timing and delay the timing for issuing the start command.

13.3 Periodic Maintenance

▲ CAUTION

- Wear protective glasses and gloves for this work, and do it with the power OFF.
- When using air blow, take care to avoid getting foreign matter in your eyes.
- Note that oil will flow out from the piping during disassembly. Also, check that there is no residual pressure in the piping before starting the work.
- When the hydraulic oil in cylinders and piping is returned to the tank, the tank may overflow. Rather than returning the hydraulic oil in cylinders to the tank, collect it in a separate oil receiver.
- Check that there is no abnormal noise, abnormal vibration, or abnormal heat generation from this product.

Inspection Location/Item	Inspection Timing/Interval	Inspection Instructions
◇ Hydraulic oil ● Oil level check ● Oil temperature check ● Oil hue check	● As necessary ● As necessary ● Once every 6 months	<ul style="list-style-type: none"> ● Check if there is a sufficient volume of oil. Also check that the hydraulic oil is not cloudy and does not include air bubbles. ● Check that the oil temperature is no higher than 60°C. (Keep it within 15 to 50°C in normal use.) ● Degradation of the hydraulic oil can be recognized based on its color. If the hydraulic oil color changes toward brown and reaches ASTM level L4: bright yellow, replace it. * For the specifications of the hydraulic oil, refer to "3.1.2 Conditions of Use".
◇ Motor cooling fan ◇ Motor unit	● Once a month ● Once a month	<ul style="list-style-type: none"> ● Check that the motor cooling fan is rotating and check for dust accumulation. ● Accumulation of a large amount of dust will lessen the cooling effect, so it should be cleaned. ● Check if the ambient temperature is too high.
◇ Controller	● Once a month	● Check if the ambient temperature is too high.
◇ Electric wiring	● Once every 6 months	<ul style="list-style-type: none"> ● Check that there are no cracks or breaks in the sheathing of the wiring. ● Measure the insulation resistance, and check that it has not dropped. ● Check that the ground is properly grounded.
◇ Gear pump	● As necessary	● In the event of an oil leak from the oil seal, the pump must be replaced. Leaked oil will be expelled through the motor's oil grooves, so inspect for oil leakage.
◇ Threads/piping ◇ Hoses	● As necessary ● As necessary	<ul style="list-style-type: none"> ● Check that no threads or piping are loose or have oil leaks. ● Check that there are no cracks or breaks, and that there is no damage.

- Take care not to get close to or come into contact with the motor cooling fan or other rotating parts while the unit is running.
- When touching the interior of the controller, abide by the following procedure to prevent electric shocks.

- 1) Shut off the source power supply to the controller. Set the circuit breaker for the entire power supply circuit to "OFF". To assure safety, hang a tag stating, for example, "Operation Prohibited (Work in Progress)" on the power supply circuit breaker, preventing erroneous operation while the work is in progress.
- 2) Wait at least 5 minutes after turning the power supply to the controller OFF before working on terminals. A capacitor with a large capacity is used inside the controller, and working while the capacitor is charged poses a risk of electric shock and other hazards. Always wait at least 5 minutes (the time required to discharge the electric charge in the capacitor) before starting work involving touching or disconnecting terminals.
- 3) When running the unit, mount all the covers over charged sections including the controller terminals before running the unit.

Draft

13.4 Cleaning/Replacement Work

Inspection	Work Timing/Interval	Work Instructions
<ul style="list-style-type: none"> Oil tank/ Replacing the oil 	Once a year	Replace the hydraulic oil at regular intervals. Use for a long time without replacing the oil will adversely affect the operation and life of the hydraulic equipment.
<ul style="list-style-type: none"> Oil cooler Cleaning the core 	Once a year	Disassemble and clean according to "13.5 Oil Cooler Maintenance Instructions".
<ul style="list-style-type: none"> Oil filler port cum air breather 	Once a year	Disassemble and clean according to "13.6 Oil Filler Port Cum Air Breather Maintenance Instructions".
<ul style="list-style-type: none"> Suction strainer 	Once a year	Disassemble and clean according to "13.7 Suction Strainer Maintenance Instructions".

▲ DANGER

- Do not get close to or come into contact with rotating parts.
- When touching the interior of the controller, abide by the following procedure to prevent electric shocks.
 - i) Shut off the source power supply to the hydraulic unit. (Set the power supply circuit breaker of the circuit that is supplying the power to "OFF".)
Hang a tag stating, for example, "Operation Prohibited (Work in Progress)" on the power supply circuit breaker or other device, preventing erroneous operation while the work is in progress.
 - ii) Wait at least 5 minutes before removing the cover, etc. from the controller. A capacitor with a large capacity is used inside the controller, and working while the capacitor is charged poses a risk of electric shock and other hazards. Always wait at least 5 minutes (the time required to discharge the electric charge in the capacitor) before removing the cover.
- When running the unit, mount all the covers on the controller before turning the power on.

13.5 Oil Cooler Maintenance Instructions

▲ WARNING

- Before starting maintenance work, stop the unit running and shut off the source power supply.
- Wear protective glasses and gloves for this work.
 - i) The cooler fins are sharp, so take care.
 - ii) When using air blow, take care to avoid getting foreign matter in your eyes.

▲ CAUTION

- Take care to ensure that no excessive forces are applied to the power cable or connector of the DC fan during the work.
- Note that oil will flow out from the piping and oil cooler during disassembly.

13.5.1 Removing the oil cooler

- 1) Disconnect the connector for the DC fan wiring.
- 2) Remove the hose clamps (2 locations), and pull off the two hoses fitted to the oil cooler. At this time, fit e.g. a blind plug to the hoses before starting further work since oil may leak due to reverse flow of oil from the tank.
- 3) Remove two cross-recessed hexagonal bolt and washer assemblies (M6 × 20L) and remove the oil cooler.

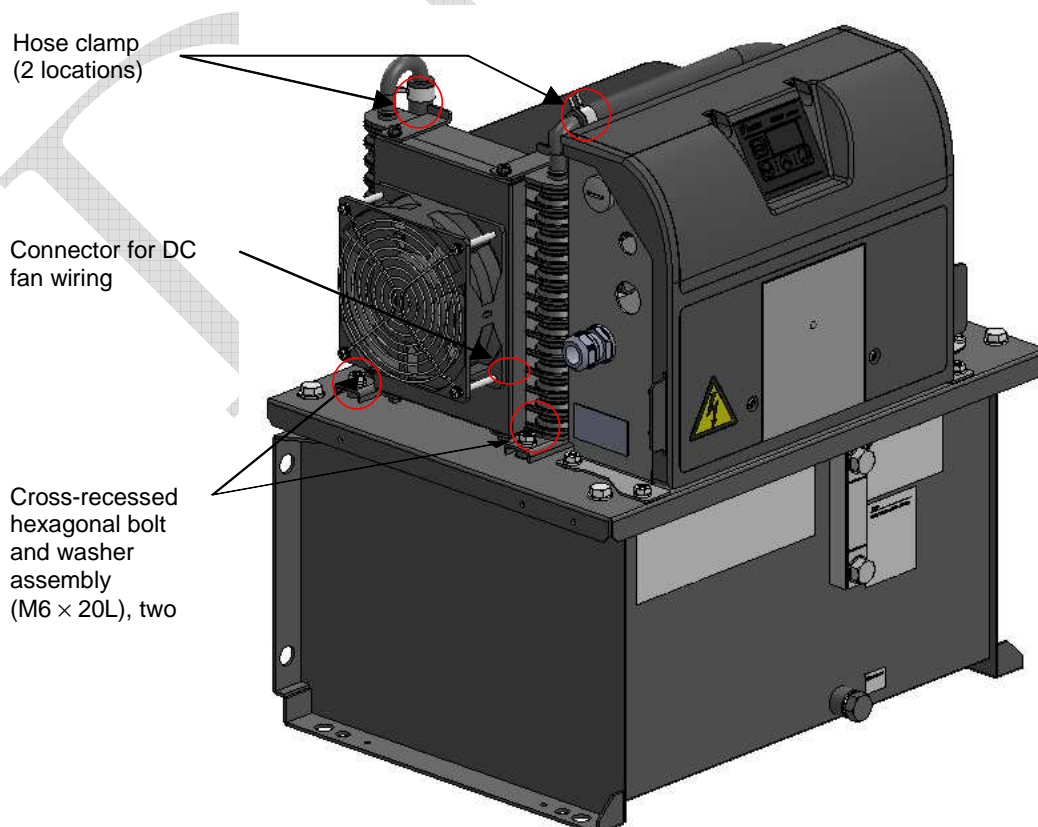

13.5.2 Disassembling the oil cooler

Remove four cross-recessed pan-head screw and washer assemblies (M5 x 10L), and separate the core and shroud. Remove four cross-recessed hexagonal bolt and flat washer assemblies (M4 x 50L), and separate the shroud, DC fan and finger guard.

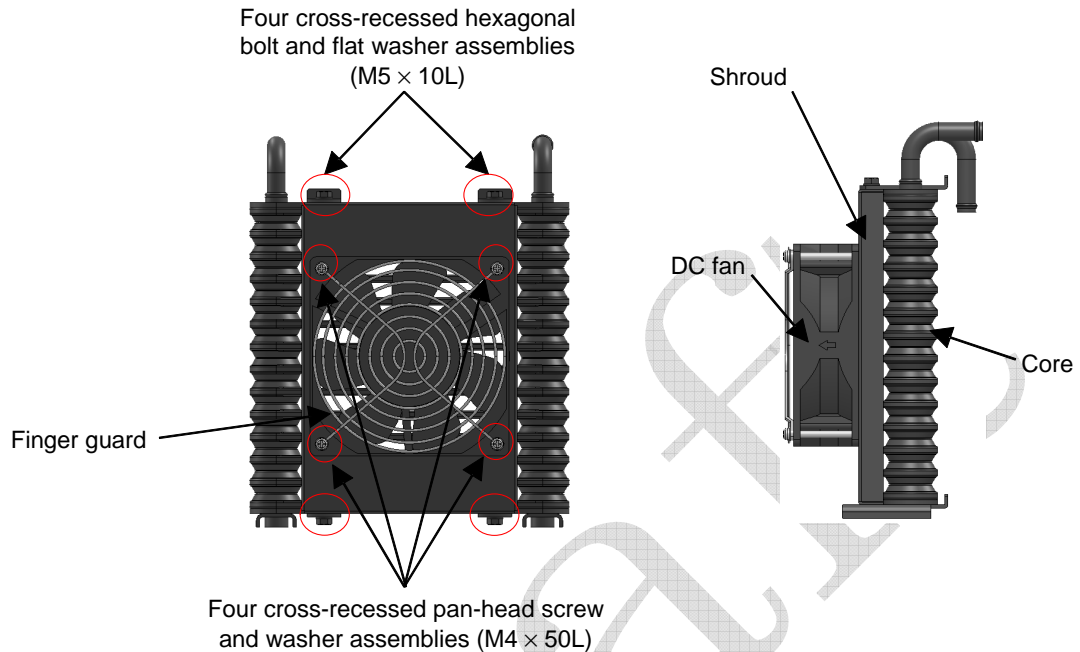

13.5.3 Cleaning the core

Steam blow or air blow the core to blow dirt and contamination that has been deposited on or is adhering to the fins, making the fin section clean. When doing this, take care to ensure that dirt or adhering material is not blown into the interior of the core.

13.5.4 Cleaning the DC fan

Using e.g. a rag, clean not just the fan blades and casing, but also the clearance between the fan blades and casing.

▲ CAUTION

- Never steam blow or air blow because foreign material will get inside the motor.

13.5.5 Reassembly

After completing the cleaning, reassemble to the original state. After completion of reassembly, check that the unit runs normally by following the test run instructions in "Chapter 10 TRIAL RUNNING". (Take care not to confuse the directions of air intake/exhaust of the oil cooler (see 7.2.1 Securing intake/exhaust space)).

13.6 Oil Filler Port Cum Air Breather Maintenance Instructions

13.6.1 Removal method

Turn the cap in the counterclockwise direction by hand and remove it.

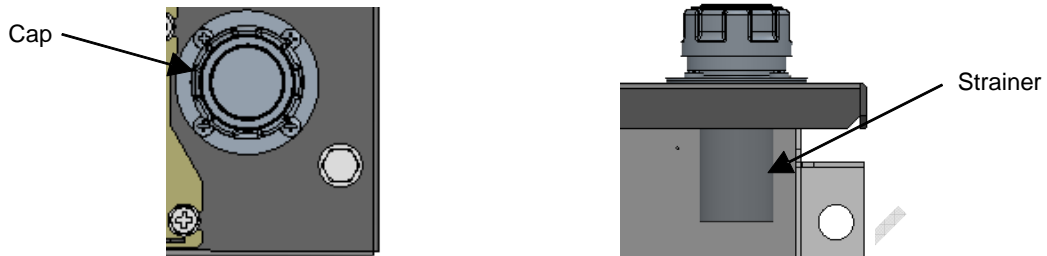

13.6.2 Cleaning

Air blow the filter section to blow off deposits and adhering material. Also remove dirt from inside the strainer's cylinder.

13.6.3 Mounting

Fit the cap by turning in the clockwise direction by hand to the position where it stops.

⚠ WARNING

- **When using air blow, wear protective glasses to avoid getting deposits and dirt in your eyes.**

13.7 Suction Strainer Maintenance Instructions

13.7.1 Removal method

- 1) Set a drain oil receiver below the oil drainage port, open the oil drain plug (M12 × 20L), and drain out all of the hydraulic oil in the tank.
- 2) Remove the four hexagonal bolts (M8 × 20L) securing the top plate and tank, and hoist the motor by its suspension plates to separate it from the tank.
- 3) This will reveal the suction strainer: loosen it with e.g. an adjustable wrench and remove it.

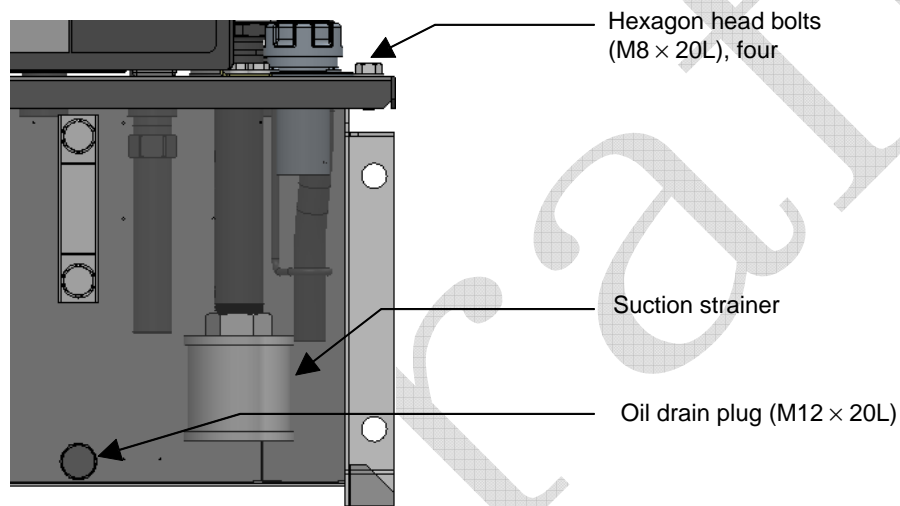

13.7.2 Cleaning

Air blow the filter section to blow off deposits and adhering material. Also remove dirt from inside the strainer's cylinder.

13.7.3 Reassembly

After completing the cleaning, reassemble by following the removal procedure in reverse. The tightening torque for the hexagonal bolts that secure the top plate and tank is 5.9 N·m. After completing reassembly, check that the unit runs normally by following the test run instructions in “Chapter 10 TRIAL RUNNING”.

▲ WARNING

- **When using air blow, wear protective glasses to avoid getting deposits and dirt in your eyes.**

13.8 High-pressure Safety Valve Adjustment Instructions

If any of the three conditions below is applicable, readjust the safety valve by referring to the [Safety Valve Adjustment Instructions].

- (1) Although the setting is such that even when used at the maximum pressure setting, the safety valve will not actuate under normal pressure control (there is an exception during transition to the main machine's hydraulic circuit blockage due to a stop of a hydraulic actuator, for example), the set pressure of the safety valve drops and it actuates even in the normal status due to repeated operation over a protracted period or contaminants in the hydraulic oil.
[Judgment method]
 - When the oil temperature rise has become faster in comparison with how it was previously.
 - When, in the pressure holding state with the motor speed displayed, turning the safety valve adjusting screw in the tightening direction lowers the motor speed.
- (2) When, for reasons such as the restricted withstand pressure of the hoses used, it is desired to as far as possible suppress surge pressures that greatly exceed the set value.
- (3) When the pressure setting has been changed after shipment from Daikin. For the purpose of suppressing surge pressure in order to protect the main machine's actuator and peripheral devices such as pressure gauges, it is advisable to set the safety valve setting to “unit set pressure + 0.5 MPa”.

[Safety Valve Adjustment Instructions]

- 1) Referring to the enlarged view of the safety valve on the next page, loosen the lock nut. (Lock nut: M10, width across flats of 14 mm)
- 2) In accordance with the guidance diagram for the length of the pressure adjusting screw, bring the screw to about the length corresponding to the desired control pressure. (The tip of the adjusting screw has four faces, with width across flats of 7 mm.)
- 3) Turn on the power to the hydraulic unit, establish the setting mode by panel key operation, and adjust the pressure setting to the desired pressure.
- 4) Select [n05] (motor rotation speed indication) in the monitor mode by panel key operation to display the current motor rotation speed.
- 5) Adjust the pressure adjusting screw length in the longitudinal direction and find the actuation start point shown in the figure below.
- 6) Turn the pressure adjusting screw clockwise three fourths of a turn from the actuation start point.
- 7) Tighten the lock nut to complete the adjustment. (When tightening the lock nut, take care that the adjusting screw does not turn.)

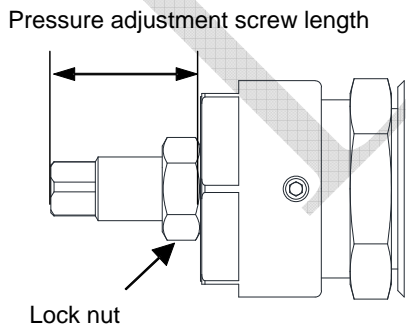
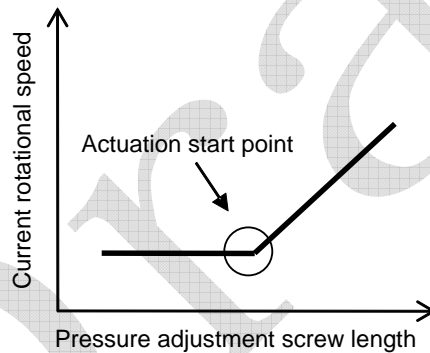

<Detail of Safety Valve>

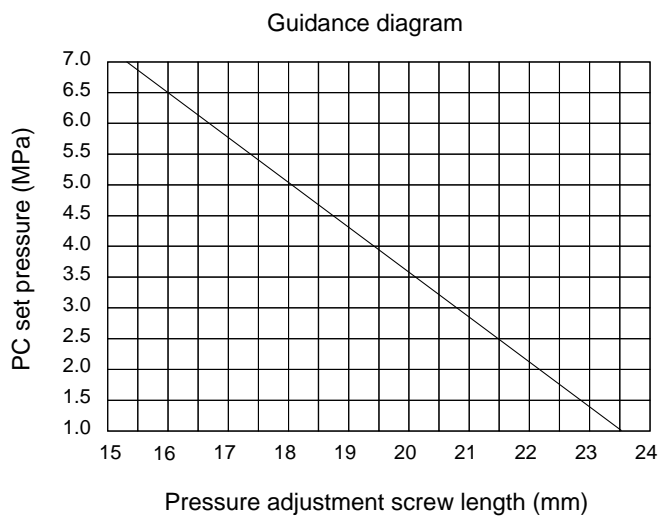

13.9 Fixed Throttle ($\phi 0.8$) Mounting Instructions

When using the unit with a set pressure of 6 MPa or higher, if the pressure becomes unstable due to the effects of contaminants, etc., mount the fixed throttle ($\phi 0.8$) provided as an accessory. Check that there is no residual pressure before mounting it.

- 1) Remove the hexagon socket head T plug (Rc 1/4).
- 2) Mount the fixed throttle (NPTF1/16 \times $\phi 0.8$).
- 3) Wrap sealing tape around the hexagon socket head T plug (Rc 1/4) and fit it as it was.

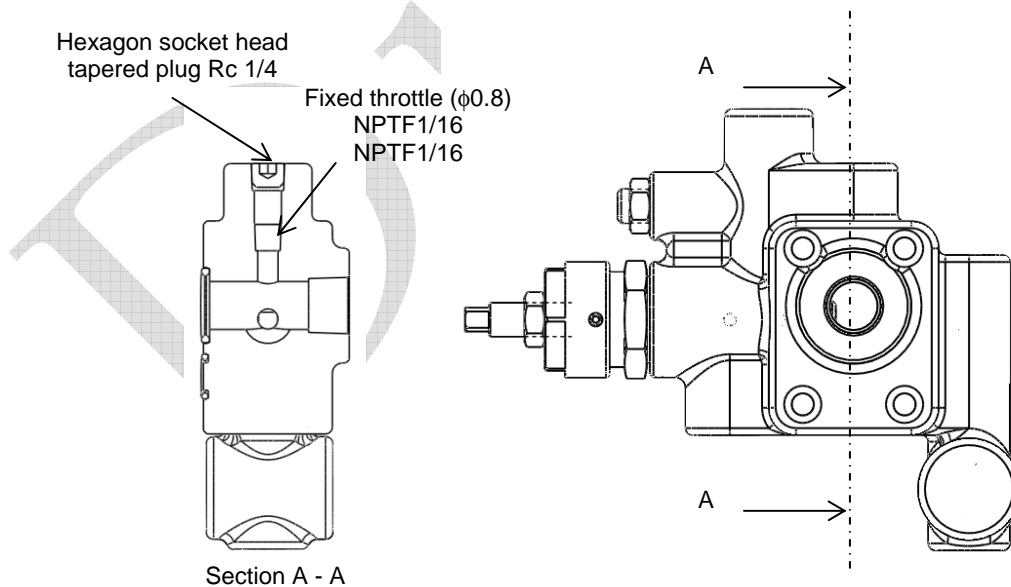
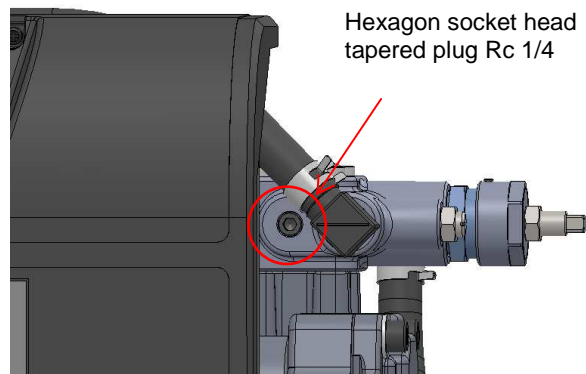

13.10 Minimum Rotational Speed Adjustment Instructions

Mounting the fixed throttle will also change the rotational speed in the pressure holding status, so adjust to the appropriate speed (380 min^{-1}).

- 1) Press the mode key on the panel to switch the display mode to the monitor mode.
- 2) Press the setting keys with the "n00" displayed to select [n05] (motor speed indication) to display the current motor speed.
- 3) Loosen the lock nut of the throttle valve for minimum rotational speed adjustment.
- 4) Adjust the throttle valve while monitoring the actual motor rotation speed displayed. (The motor rotation speed decreases during clockwise rotation, and increases during counterclockwise rotation.)
- 5) Tighten the lock nut to complete the adjustment.
- 6) Press the mode key to switch to actual pressure indication.

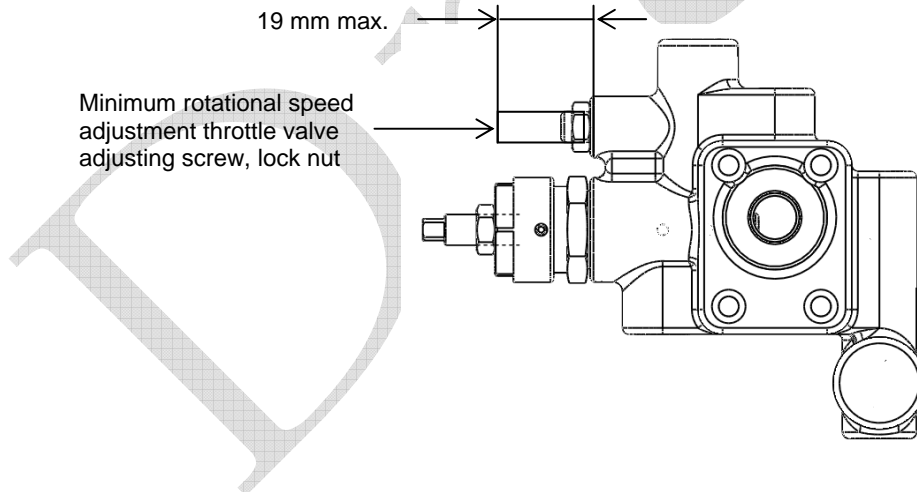

▲ CAUTION

- If the minimum rotational speed adjustment throttle valve adjusting screw is loosened too far it will come out and oil will spout out.
Ensure that the adjusting screw does not project beyond 19 mm from its mount.

Chapter 14. Output Signal Timing Charts

The start/stop signals (digital input 0) in the timing charts all assume that the value set for [P00: Start/stop signal switching] is "1" (default value).

When the value set for [P00: Start/stop signal switching] is "0", the ON and OFF statuses of the start/stop signal (digital input 0) are inverted.

14.1 Timing Chart at Powering Up

The timing chart at powering up differs depending on the type of power supply as shown below.

■ When sharing control power supply:

- Judge the charging completed/not completed status based on the alarm output or DOUT (READY output).
- An alarm output before charging or after stopping indicates an abnormal status.

■ Common power supply source to control and main circuit

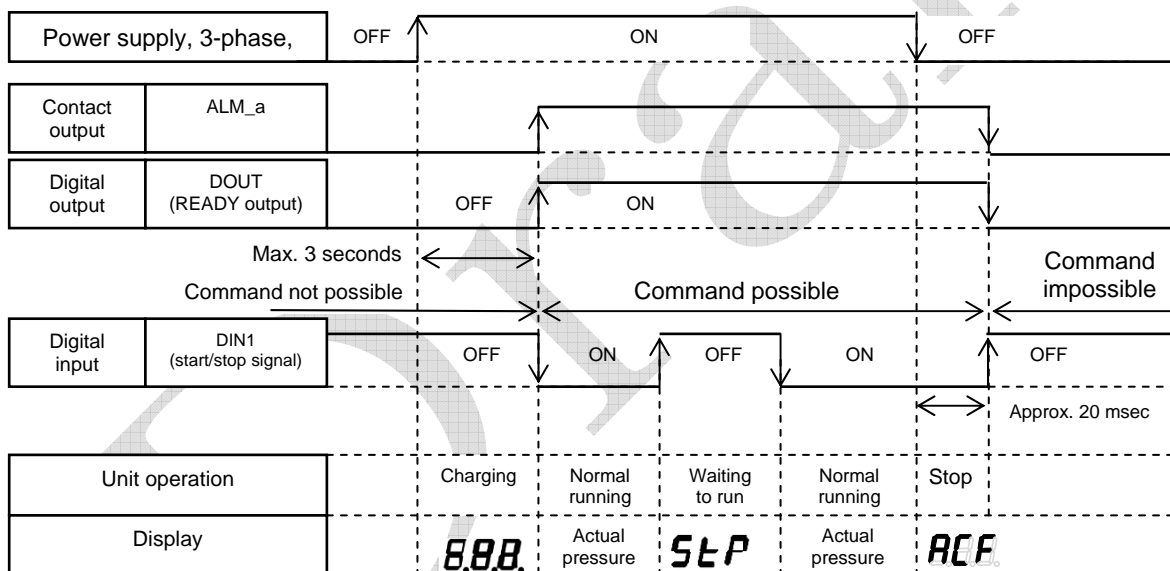

■ **Separate power supply source to control circuit**

- Judge the charging completed/not completed status based on DOUT (READY output).
- An alarm output before or after turning on the control power indicates an abnormal status.
- An alarm output before charging the main circuit or after shutting it off indicates an abnormal status.

■ **Individual power supply source to control and the main circuit**

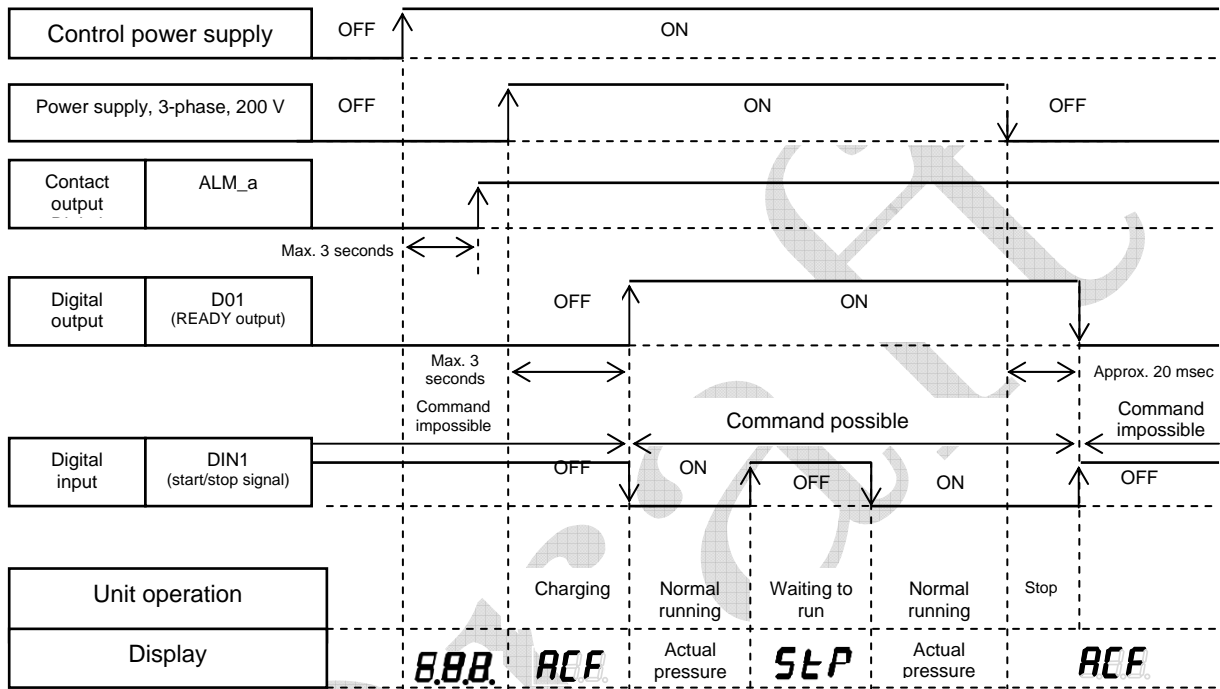

Chapter 15. ABOUT Hybrid-Win (MAINTENANCE/CONTROL FUNCTIONS)

Hybrid-Win is a software tool for reading and controlling the information of a Daikin hybrid system (SuperUnit, ECORICH, Oilcon, etc.) on a personal computer. It makes it possible to set and monitor parameters efficiently from a Windows screen on the personal computer.

■ Main functions

(1) Graph display

The pressure, flow rate, and other inverter internal data, can be monitored and displayed in graph form. This can speed up tasks such as checking operations during test running, adjusting parameters such as time constants, and investigating the cause when trouble occurs.

(2) Reading, writing, editing and saving parameters

By editing parameters on a personal computer and batch writing them to the hybrid system, the time taken to set them can be shortened considerably. Reading and saving set values makes control easier.

(3) Reading and saving the alarm history

This is useful for speeding up the identification of parts that need maintenance, and shortening stoppage times. It serves as a guide for determining the replacement of consumable parts based on "operating time", and maintenance intervals. Troubleshooting, including the diagnosis of the causes of alarm occurrences, and corrective actions, can be displayed.

* Hybrid-Win is a software tool for monitoring the internal status with a personal computer. The tool itself and its instruction manual can be downloaded free of charge after registering as a user in the website (<http://www.daikinpmc.com/>).

* The communication cable must be purchased separately.

* There are some models that require separate, model-specific monitor harnesses.

* It is possible to add a wireless module to connect to smart phones or a wireless LAN (available as an option). This helps with the users' daily inspections, maintenance and remote monitoring.

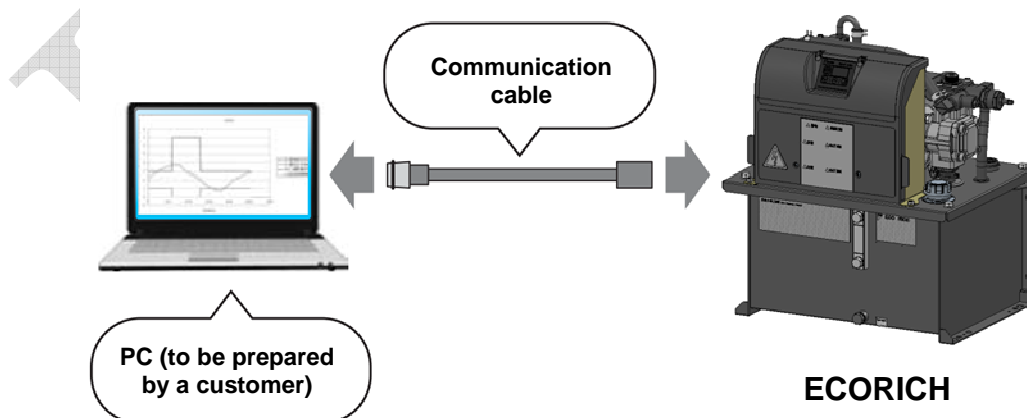

DAIKIN INDUSTRIES, LTD.

Oil Hydraulic Equipment

Osaka Office

YODOGAWA PLANT

1-1, Nishi-Hitotsuya, Settsu, Osaka 566-8585, Japan

Phone: 81-6-6349-4475

Fax.: 81-6-6349-7862

Home Page: <http://www.daikinpmc.com/en/>

Contact: <http://www.daikin.com/contact/hydraulic/>

For requirements on Maintenance Repair Operation;

All World Machinery Supply, Inc.

a member of Daikin Group

6164 All World Way, Roscoe, IL 61073, U. S. A.

Phone: +1-815-943-9111

Fax.: +1-815-943-5370

Home Page: <http://www.allworldmachinery.com/us/>