

Hybrid Hydraulic System

SERVICE GUIDE

<Design No. 40 Series>

ECORICH (EHU Series)



DAIKIN INDUSTRIES, LTD.

Preface

Thank you very much for your support for Daikin products.

We are pleased to present the completed Service Guide for the EHU #40 series (Design No. 40 series).

Daikin has assembled a comprehensive range of models to respond to needs for advanced functions and energy savings in hybrid hydraulic systems.

This Service Guide contains information for troubleshooting and service. Please use it as reference during service work.

Document Name	Models Covered	Date of Issue
ECORICH EHU #40 Series Design No. 40 Series SERVICE GUIDE	• EHU #40 Series	November 2016

November 2016

DAIKIN INDUSTRIES, LTD.

Hybrid Hydraulic System

SERVICE GUIDE

1	Unit Models	6
1	1 Model List	6
2	2 Nomenclature	7
2	Standard Specifications.....	9
1	1 Principle of ECORICH	9
2	2 Specification List	10
3	3 Component Parts And Part Names.....	11
4	4 Electric Wiring Diagram	14
5	5 Hydraulic Circuit Diagram	15
6	6 Descriptions of Function Operations.....	16
3	Control Panel.....	17
1	1 Explanation of Operation Keys	17
2	2 Organization of Modes.....	18
3	3 Operating Procedure	27
4	Troubleshooting.....	34
1	1 Operating Procedure for Service	34
2	2 Preparation for Investigation of Alarms	35
3	3 Troubleshooting by Each Symptoms	38
4	4 Error Code List	47
5	5 Troubleshooting Flowchart.....	49
5	Settings at Part Replacement.....	84
1	1 Checking the Setting Data	84
2	2 Setting Procedure	84
3	3 Parameter Setting List	85
4	4 Supplementary List of Default Settings for Writing to the Main PCB.....	89
6	Annexes (Work Procedures Manuals).....	91
1	1 List of Annexes (Work Procedures Manuals).....	91
	ECORICH (No. 40 Design) Controller Replacement Procedure	92
	ECORICH (No. 40 Design) Motor Pump Replacement Procedure	95
	ECORICH (No. 40 Design) Motor Replacement Procedure	97
	ECORICH (No. 40 Design) Pressure Sensor/Safety Valve Replacement Procedure	98
	ECORICH (No. 40 Design) Pressure Sensor Connector Connection Check Procedure	102
	ECORICH (No. 40 Design) DC Fan Harness Connector Connection Check Procedure	104
	ECORICH (No. 40 Design) Pressure Sensor/DC Fan Harness Replacement Procedure	106
	ECORICH (No. 40 Design) DC Fan and Oil Cooler Cleaning/Replacement Procedure	108
	ECORICH (No. 40 Design) Suction Strainer Cleaning/Replacement Procedure	111
	ECORICH (No. 40 Design) Hydraulic Oil Change Procedure.....	114
	ECORICH (No. 40 Design) DC Fan Motor Fuse Replacement Procedure.....	115
	ECORICH (No. 40 Design) Motor Coil/Power Device Resistance Measurement Procedure	116
	ECORICH (No. 40 Design) Input Power/Ground Fault Check Procedure	118
	ECORICH (No. 40 Design) Controller PCB Replacement Procedure.....	120
	ECORICH (No. 40 Design) Harness Connection Check Procedure	126
	ECORICH (No. 40 Design) Variable Relief Pressure/Minimum Rotation Speed Adjustment Procedure.....	130
7	Part List	139

- Note that specifications and other information in this guide are subject to change without notice due to product improvements.
- Unauthorized reproduction, transfer or distribution through a network of the information in this guide is prohibited.

SAFETY PRECAUTIONS

(To be Observed Without Fail)

The precautions shown here serve to prevent hazards and injury to you and others.

The probable consequences of incorrect operations are categorized with the following indications.

▲ DANGER

This indication panel shows consequences involving an immediate danger of death or serious injury.

▲ WARNING

This indication panel shows consequences involving the possibility of death or serious injury.

▲ CAUTION

This indication panel shows consequences involving the possibility of injuries, or the occurrence of property damage only.

▲ DANGER

- Entrust to people with required expertise only



Mandatory

Ensure that transportation, installation, piping, wiring, running, operation, maintenance and inspection work are carried out by people with the required expertise.

Check the power supply used (voltage, frequency).

- Do not run unit with covers open



Prohibited

Do not run the unit with the external covers removed.

This could cause an electric shock.

- Check specifications when connecting power supply



Prohibited

Connect the power supply cable in the manner described on the wiring diagram or in the instruction manual.

Incorrect wiring could cause electric shock or fire.

- Not to be used outside the specifications



Mandatory

Do not use this product outside the specifications stated in the catalog and the delivery specifications.

This could cause serious accidents involving damage to the main machine, injuries, fire or electric shock.

- Ground without fail



Grounding

Failing to make a ground connection could cause electric shock.

Be sure to connect the ground wire in accordance with the laws and regulations in the country concerned.

▲ DANGER

- Check mass and suspend at stipulated location



Mandatory

Check the mass on the nameplate, then suspend the product at the location stipulated on the outline drawing, keeping within the rated weight for the hoisting equipment.

There is a risk of injury or damage due to the product falling or overturning.

- Shut off power before starting work



Mandatory

Be sure to shut off the power supply before starting the work. Working while the wires are live could result in electric shock.

- Do not use in explosive atmosphere



Prohibited

Do not install the product at a location where there is a risk that combustible gas will be generated, flow in, be retained or leak, or a location where there are airborne carbon fibers.

- Wait at least 5 minutes after shutting off power



Prohibited

The internal high-voltage electrical components (capacitors) will not have finished discharging, so there will be a risk of electric shock.

- Do not expose to water



Prohibited

Do not put the product in water or splash water on it. This could cause short circuiting or electric shock.

▲ WARNING

- Carry out wiring based on the standards



Mandatory

Perform wiring in compliance with the “electrical equipment technical standards” and “indoor wiring regulations”.

Otherwise there will be a risk of burnout and fire.

For products destined overseas, implement wiring based on the standards of the relevant country.

- Use commercial power supply



Mandatory

Be sure to use a commercial power supply.

Using an inverter power supply, etc., may cause burnout.

▲ WARNING

- Do not approach product during transport with hoisting equipment



Prohibited

Never approach the product while it is being transported using hoisting equipment.
There is a risk of injury or damage due to the product falling or overturning.

- Do not insert fingers/objects into gaps in equipment



Caution

For safety, rotating parts are provided with covers or casings, but do not insert your fingers or objects into the gaps.
This could result in injury.

- Use the equipment secured



Prohibited

Check the positions where the product is to be secured on the outline drawing, and secure it accordingly without fail.
There is a risk of the product falling or overturning due to hydraulic pressure in the piping.

- If an error occurs, stop running immediately



Mandatory

When an error has occurred, suspend running the product until the cause has been eliminated with certainty.
Otherwise there will be a risk of damage, electric shock, fire, and injury.

▲ CAUTION

- Do not use in special atmospheres



Prohibited

Do not use the product in special atmospheres such as high temperatures or high humidity.

- Check safety of main machine before commissioning



Mandatory

Before starting commissioning, check that the main machine is in a safe status (will not operate, or no accident will occur even if it does operate).
Otherwise there will be a risk of injury and damage.

- Place no object close to air inlet/outlet



Prohibited

Do not place any obstruction within 100 mm of the air inlet or outlet.
If the air inlet/outlet is obstructed, there will be a risk that product operation will stop, or that its service life will be shortened.

- Remove spacers before starting operation



Mandatory

Remove the spacer for protecting the rubber vibration isolator before starting operation.
Otherwise there will be excessive noise and vibration.

▲ CAUTION

- **Install on a flat location**



Mandatory

Install the product on a flat location.
Installing it inclined can cause malfunctions due to oil leakage and inclusion of air.

- **Bleed air at low pressure**



Mandatory

Be sure to use a low pressure for bleeding air.
Otherwise there will be a risk of injury by oil gushing out at high pressure.

- **Do not run pump with no load**



Prohibited

Before starting operation, check that the hydraulic piping has been completed properly and that there is the correct quantity of oil in the tank.
If the pump is run with no load, it will be damaged.

Also note that the oil level may fluctuate considerably depending on the circuit at the main machine side.

- **Do not transport with oil in tank**



Mandatory

Do not transport the product with hydraulic oil in the tank.
This could cause malfunctions due to oil leaks or inclusion of air.

- **Do not climb onto the product**



Prohibited

Do not sit on or climb onto the product.
This could cause injury due to the product falling or overturning.

- **Wear gloves/protective goggles for maintenance/inspection/cleaning**



Mandatory

There is a risk of cutting your fingers on the edges of the oil cooler's fins.
There is also a risk of dirt getting into your eyes while air blowing.
Also note that the pump and valves can reach quite high temperatures due to temperature rise of the motor and oil, so there is a risk of burns if they are touched with bare hands.

- **Secure robustly during transport**



Mandatory

Secure the product robustly so that it will not move due to vibration or external forces during transportation.
Exposure to excessive vibration or external forces risks damaging internal devices.

1 Unit Models

1 Model List

	Applicable Model	Motor Capacity [kW] (Equivalent to)	Tank Capacity [L]	Maximum Discharge Rate [L/min] (*1)	Maximum Operating Pressure [MPa]
ECORICH	EHU1404-40	0.75 kW	18	15.2	4.0
	EHU2504-40	1.5 kW		25.1	
	EHU2507-40	2.2 kW			28.5
	EHU3007-40	2.8 kW			

*1 The discharge rate figures are the theoretical discharge rate.

	Option			
Model	EHU1404-40	EHU1404-40-C	EHU1404-40-S	EHU1404-40-SC
	EHU2504-40	EHU2504-40-C	EHU2504-40-S	EHU2504-40-SC
	EHU2507-40	EHU2507-40-C	EHU2507-40-S	EHU2507-40-SC
	EHU3007-40	EHU3007-40-C	EHU3007-40-S	EHU3007-40-SC

2 Nomenclature

				Controller Option				Unit Option							
(1)	(2)	(3)	(4)	(5)	(6)	(7)	(8)	(9)	(10)	(11)	(12)	(13)	(14)	(15)	
EHU	**	**	-	40	-	*	*	*	*	-	*	*	*	*	*

(1) Model No.

- EHU: ECORICH Series

(2) Maximum discharge rate

- 14: 14 L/min (4 MPa only)
- 25: 25 L/min
- 30: 28 L/min (7 MPa only)

(3) Maximum operating pressure

- 04: 4 MPa
- 07: 7 MPa

(4) Design No.

- 40 series

(5) Power supply input specifications

- (None): Standard (3-phase 200 V)

(6) Control power supply option

- (None): Standard (none)
- S: With separated power supplies for power and control lines

(7) Communications option

- (None): Standard (none)
- C: RS422/485 communication The factory default setting is RS422 communication.

(8) Function option

- (None): Standard (none)
- N: No controller option and with unit options

(10 to 15) Non-standard control number

- (None): Standard product
- 3-digit number or unit codes

Code	Details
F	Water fill test tank
M	Water leak test tank
J	Microseparator
B	Oil filler port (yellow cap)
G	Oil level gauge guard (yellow)
E	Oil level gauge guard (black)
L	Level switch ("NO" contact)
H	Level switch ("NC" contact)
P	Temperature switch ("NC" contact)
K	Thermometer
A	Mounting conversion plate for compatibility

1 Unit Models

Notes on Nomenclature

- 1) If there is no option, the code ends at item (4) on the previous page.
Example: EHU2504-40
- 2) When a unit option is added to the basic unit, one letter of the alphabet "N" is inserted.
Example: EHU2504-40-N-(unit option)
- 3) When a controller option is selected, the relevant letters of the alphabet (from 1 to 4 characters) are allocated.
Example:
EHU2504-40-C-(option)
EHU2504-40-SC-(option)
- 4) If there is no unit option, the code is terminated at the controller option, and "-" (the hyphen) is deleted.
Example:
EHU2504-40-SC
- 5) Regarding codes for other options or non-standard unit control number:
 - (1) Codes for other options shall comprise up to six alphabetic characters, in ascending sequence with left-alignment.
 - (2) Non-standard unit numbers shall comprise three numerical digits.
Example: -BFGJKL, -123
* (1) and (2) shall not be combined. Bad example: -BG001

1 Principle of ECORICH

(1) System configuration

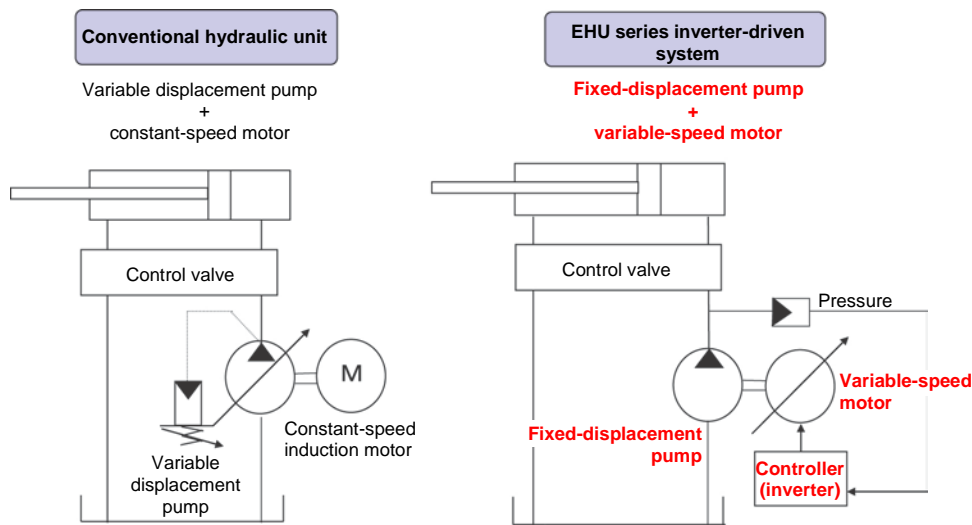

(2) Energy-saving principle

Operating pattern of hydraulic unit

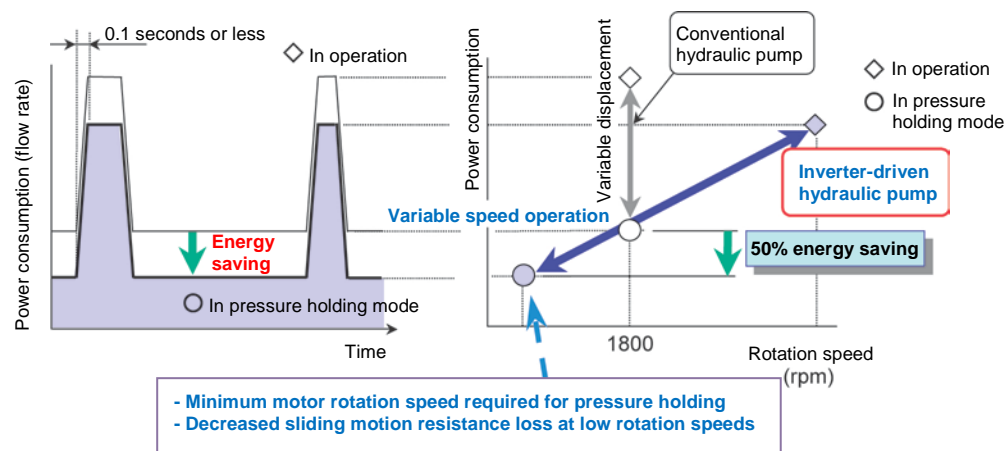

(3) Features

- 30% energy saving possible (in pressure holding mode/comparison with Daikin design No. 30 series)
 - The highly efficient IPM motor surpassing IE4 class further improves the energy-saving effect of the unit.
- Compact/Lightweight
 - Equipping the unit with a compact motor reduces its footprint for easier installation.
- Environmental resistance

A more reliable controller improves environmental adaptability.

- Permissible ambient temperature increased from 35°C on No. 30 series to 40°C
- Dustproof and waterproof protection rating: IP44
- Tank capacity: 10 on No. 30 series to 18 L

2 Standard Specifications

2 Specification List

Model Name		EHU1404	EHU2504	EHU2507	EHU3007
Motor capacity (kW equivalent)		0.75	1.5	2.2	2.8
Supply power		AC 3-phase 200/200/220 V, 50/60/60 Hz			
Tank capacity (L)		18			
Hydraulic pump (cc/rev)		4	5.8		
Pressure	Maximum pressure (MPa)	4.0		7.0	
	Adjustment range (MPa)	1.5-4.0		1.5-7.0	
Flow rate	Maximum flow rate (L/min)	15.2	25.1		28.5
	Adjustment range (L/min)	2.5-15.2	3.5-25.1		3.5-28.5
Mass (not including hydraulic oil) (kg)		26		29	
External dimensions		432 (w) × 328 (d) × 487 (h) mm			
Coating color		Black (Purchased parts, etc.: standard color of the equipment manufacturer)			
Discharge port size		Rc3/8, 1 location			
Return port size		Rp1/2, 2 locations/1 location (in the oil)			
Return port size (above the oil level)		Rp1, 1 location			
Digital input (3 channels)		Photo coupler insulation, DC +24 V (max. 27 V) 5 mA, positive or negative common			
Digital output (1 channel)		Photo coupler insulation, open collector output, DC +24 V (max. 27 V) 50 mA max., positive or negative common			
Alarm output (1 channel)		Relay output, contact capacity: DC 30 V max. 1A, ALM NO: open when abnormal/ALM NC: closed when abnormal/COM: common			
Communications port (RS-485/RS-422)		Serial communications port * Can be used only with communications option			
Communications port		(UART): Communications port for service * For communications with a personal computer, a dedicated USB-UART communications converter is required.			
Usable oil		Type: Mineral-oil base hydraulic oil/wear resistance hydraulic oil Viscosity grade: ISO VG32-68 Dynamic viscosity range: 15 to 400 mm ² /s (recommended values: 20 to 88 mm ² /s) Contamination: Within NAS class 10, water content 0.1% volume max.			
Tank oil temperature		0 to 60°C (recommended temperature: 15 to 50°C)			
Ambient temperature		0 to 40 °C			
Humidity		85% RH maximum (no dew condensation)			
Control power supply input (when control power supply option selected)		1-phase, 200 V/220 V, 50/60 Hz			
Operating altitude		1,000 m maximum			
Installation site		Indoors (Be sure to fix with bolts, etc.)			

3 Component Parts And Part Names

(1) Unit

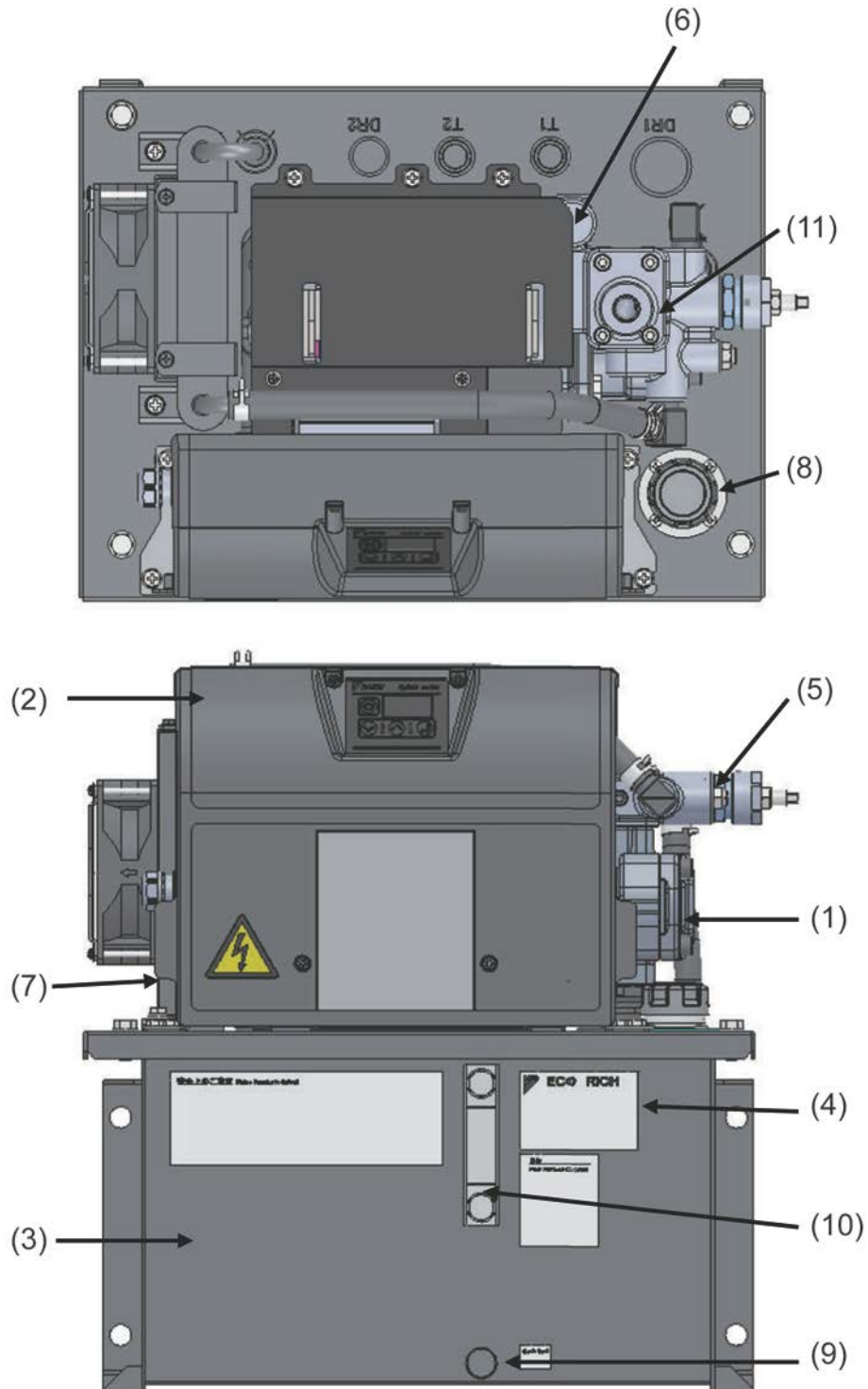

(1): Motor pump	(7): Oil cooler
(2): Controller	(8): Oil filler port with air breather
(3): Tank	(9): Oil outlet port cum oil drain port
(4): Unit nameplate	(10): Oil level gauge
(5): Relief valve block	(11): Discharge port Rc 3/8
(6): Pressure sensor	

2 Standard Specifications

(2) Controller

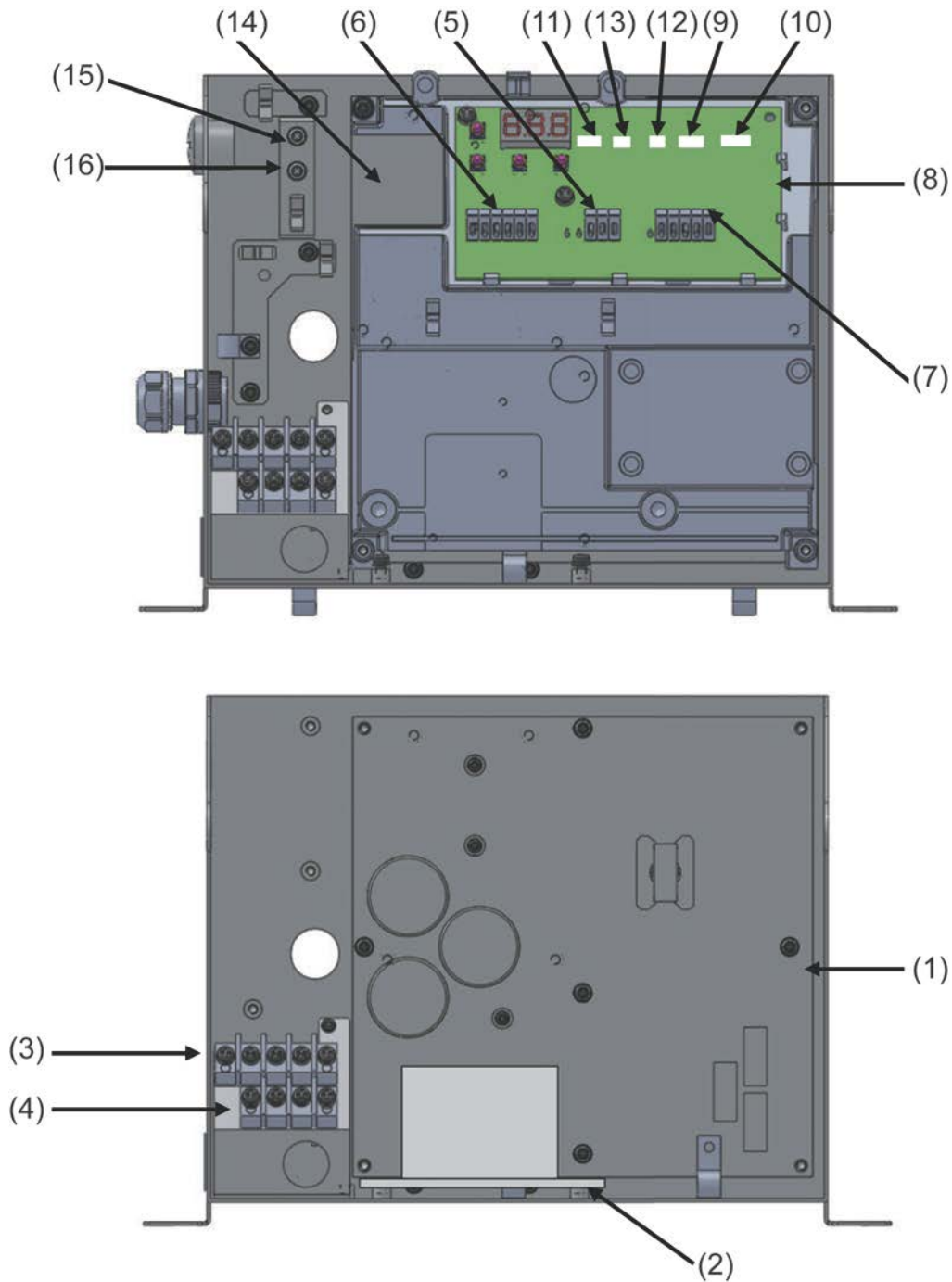

(1): Power PCB	(9): Connector for DC fan
(2): DC reactor (EHU2507, EHU3007 only)	(10): Fuse for DC fan
(3): Power supply connection terminal	(11): Pressure sensor connector
(4): Control power supply terminals (when control power supply option selected)	(12): Motor thermistor connector
(5): Alarm output terminals	(13): Oil temperature thermistor connector
(6): Digital I/O terminals	(14): Motor connection terminals
(7) RS422/485 communication terminals	(15): Motor ground terminal
(8): Interface PCB	(16): Control signal ground terminal

(3) Motor pump

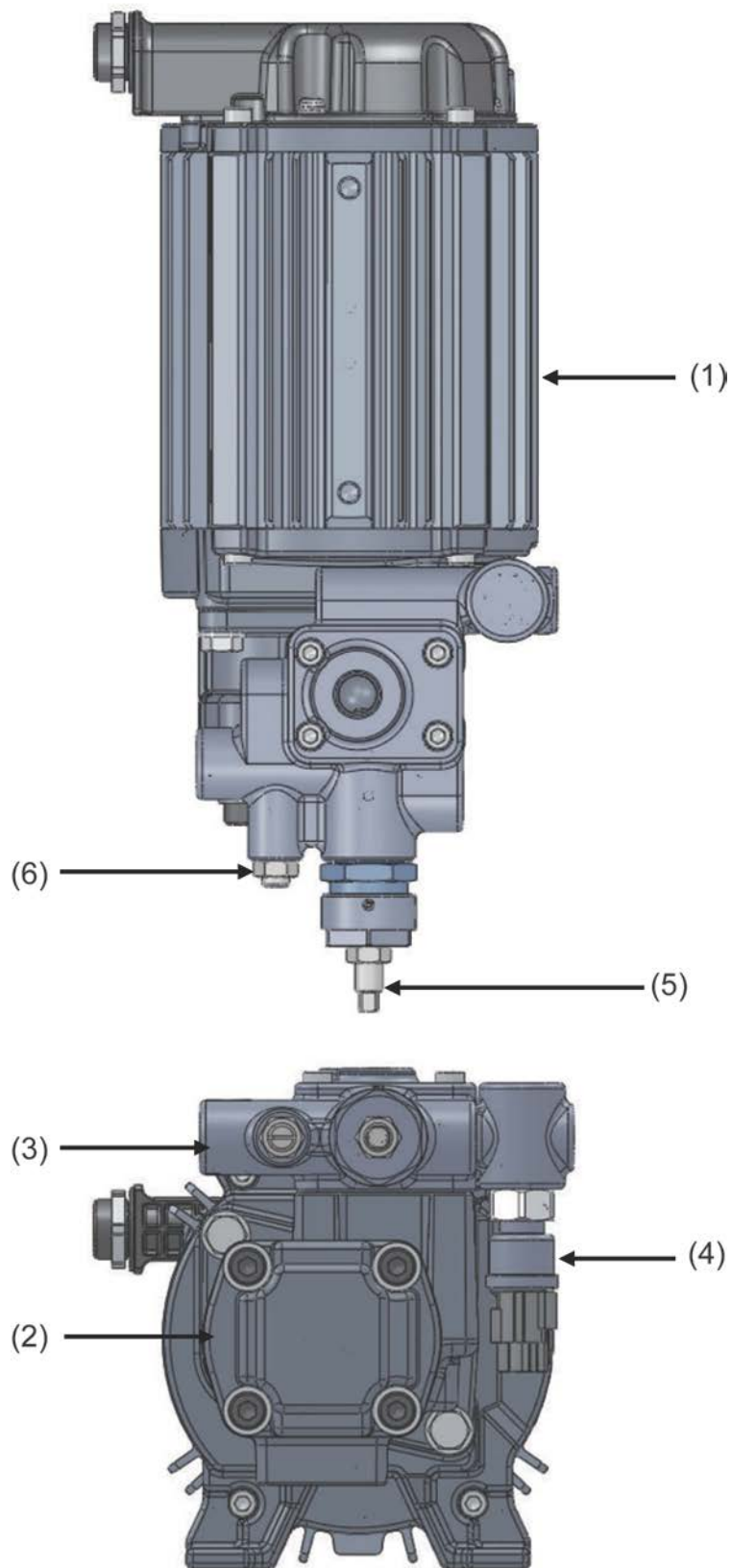

(1): Motor	(4): Pressure sensor
(2): Pump	(5): Relief pressure adjustment screw
(3): Relief valve block	(6): Minimum rotation speed adjustment throttle

2 Standard Specifications

4 Electric Wiring Diagram

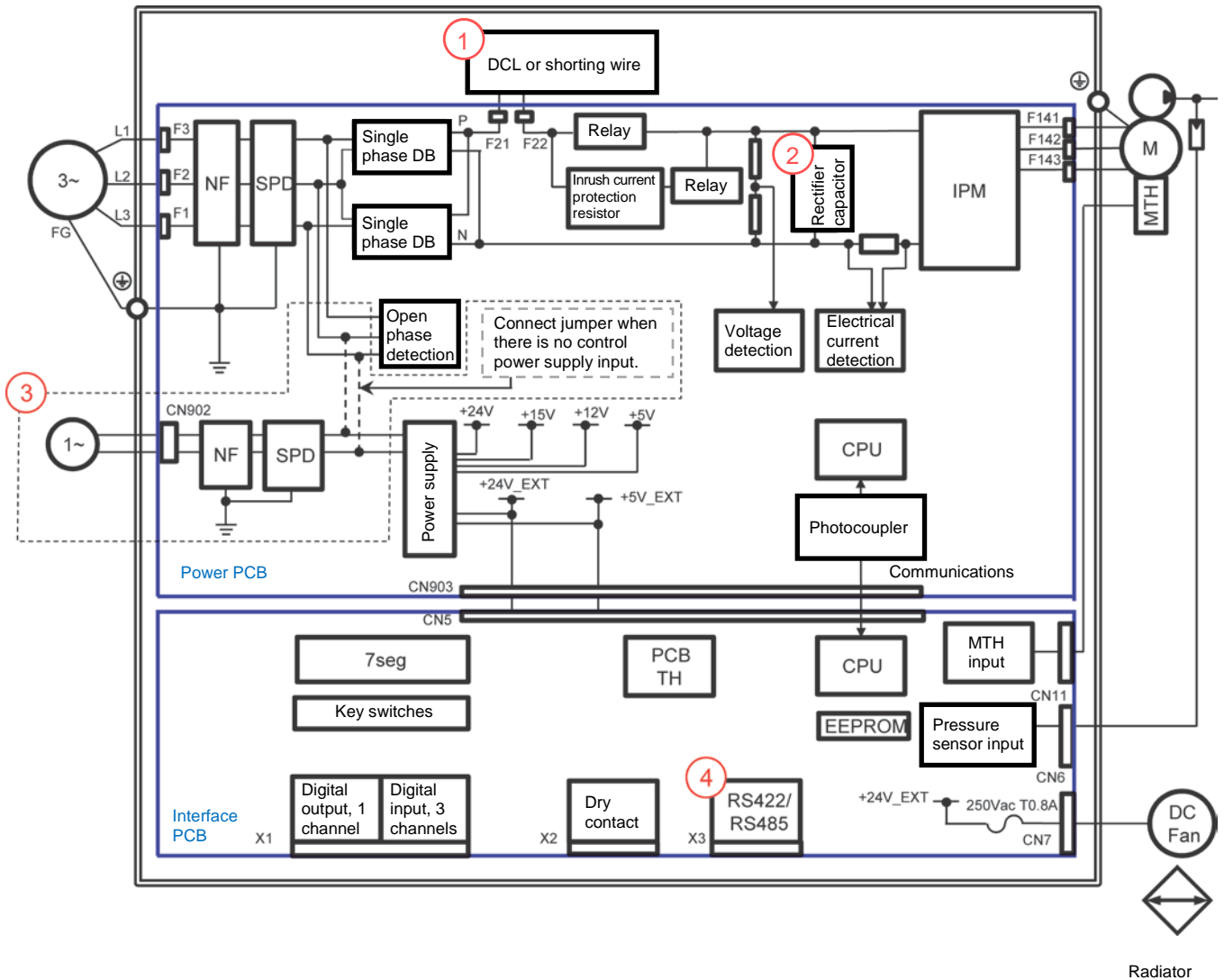

Setting Controller Internal Components for Each Model

		1. DCL or short-circuit wiring	2. Rectifier capacitor	3. Control power supply input	4. RS422/485
Standard	EHU1404-40	Short-circuit wiring	One pc.	None	None
	EHU2504-40				
	EHU2507-40	DCL	Two pcs.		
	EHU3007-40				
Communications	EHU1404-40-C	Short-circuit wiring	One pc.		
	EHU2504-40-C				
	EHU2507-40-C	DCL	Two pcs.		
	EHU3007-40-C				
Control power supply	EHU1404-40-S	Short-circuit wiring	One pc.	Yes	None
	EHU2504-40-S				
	EHU2507-40-S	DCL	Two pcs.		
	EHU3007-40-S				
Communications + control power supply	EHU1404-40-SC	Short-circuit wiring	One pc.	Yes	Yes
	EHU2504-40-SC				
	EHU2507-40-SC	DCL	Two pcs.		
	EHU3007-40-SC				

5 Hydraulic Circuit Diagram

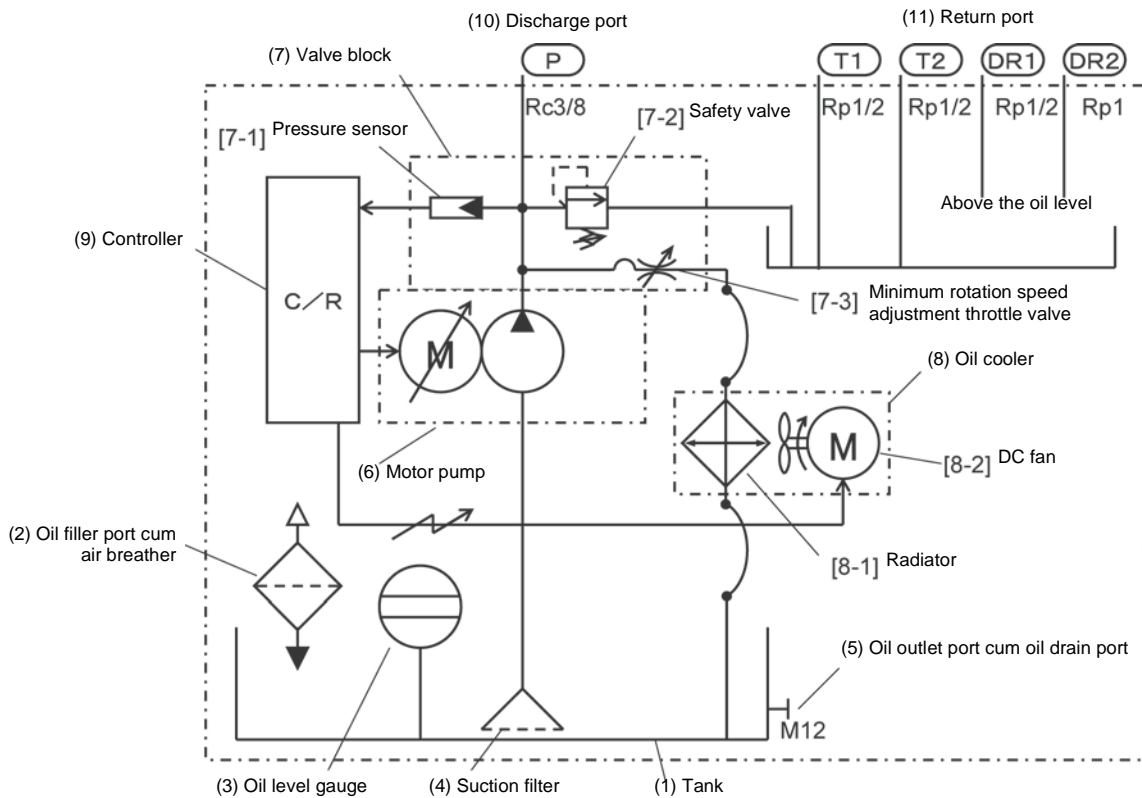

No	Part Name	Function
(1)	Tank	Stores hydraulic oil.
(2)	Oil filler port cum air breather	Functions as both a filter when filling and as a vent filter when the hydraulic oil level changes.
(3)	Oil level gauge	Shows the level of the hydraulic oil in the tank.
(4)	Suction filter	Filters hydraulic oil when suctioning.
(5)	Oil outlet port cum oil drain port	Functions as both a waste oil port and as a sampling port when inspecting the hydraulic oil.
(6)	Motor pump	Suctions in hydraulic oil and discharges pressurized oil.
(7)	Valve block	Incorporates valves necessary for discharging oil.
7-1	Pressure sensor	Detects the pressure of the discharged oil.
7-2	Safety valve	Prevents high pressures being generated by surge pressure.
7-3	Minimum rotation speed adjustment throttle valve	Serves to stabilize the rotation speed to hold the pressure.
(8)	Oil cooler	Cools the hydraulic oil that has passed through the minimum rotation speed adjustment throttle valve.
8-1	Radiator	Exhausts heat from the hydraulic oil circulating internally.
8-2	DC fan	Creates an air flow in order to improve the heat exhaust efficiency.
(9)	Controller	Controls the set pressure and flow rate autonomously according to the load condition.
(10)	Discharge port	Discharges controlled pressurized oil.
(11)	Return port	Used to return discharged hydraulic oil. T port: Returns the returned oil into the hydraulic tank. DR port: Returns the returned oil above the level of the hydraulic oil in the tank (no back pressure in the tank).

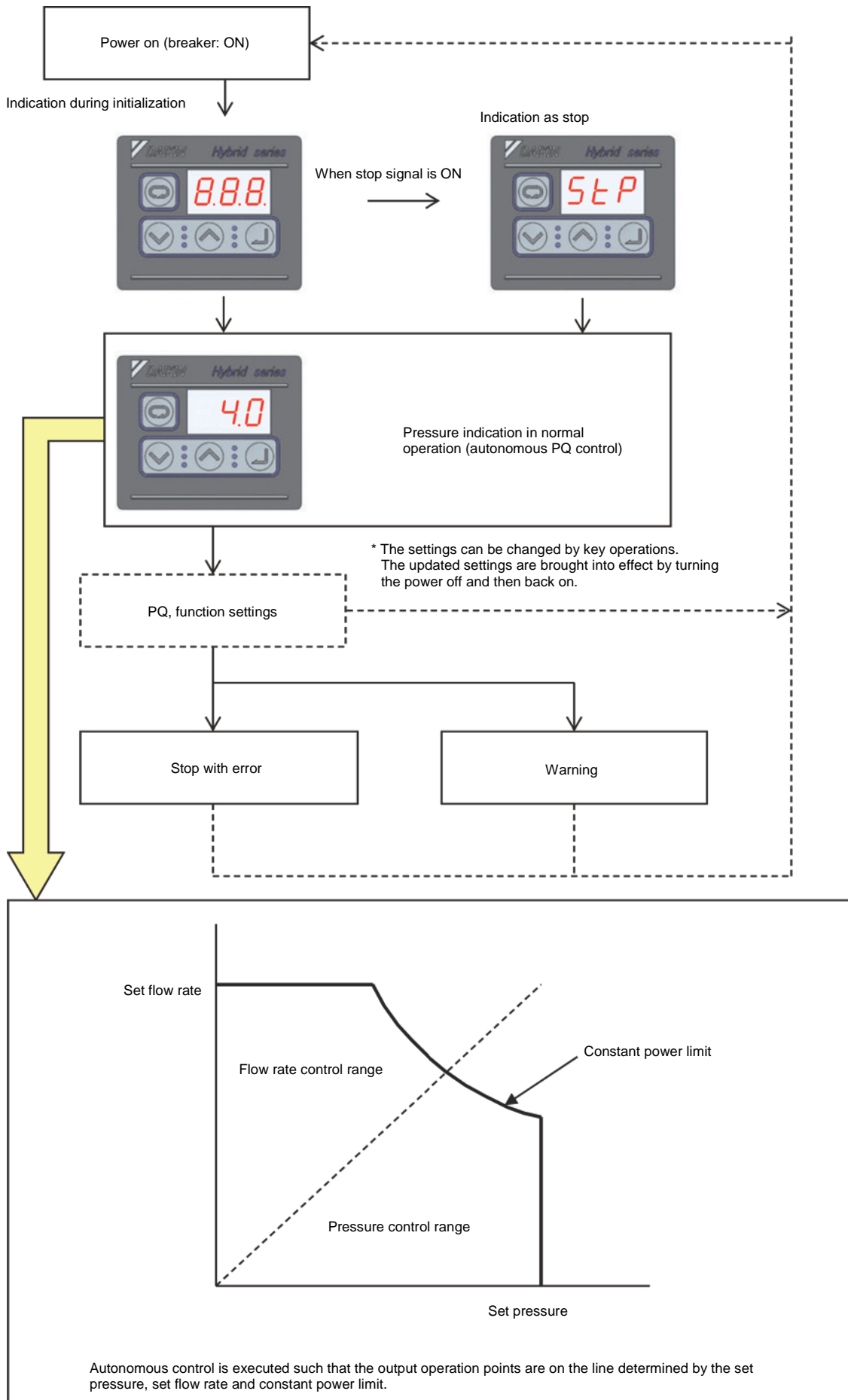

2 Standard Specifications

6 Descriptions of Function Operations

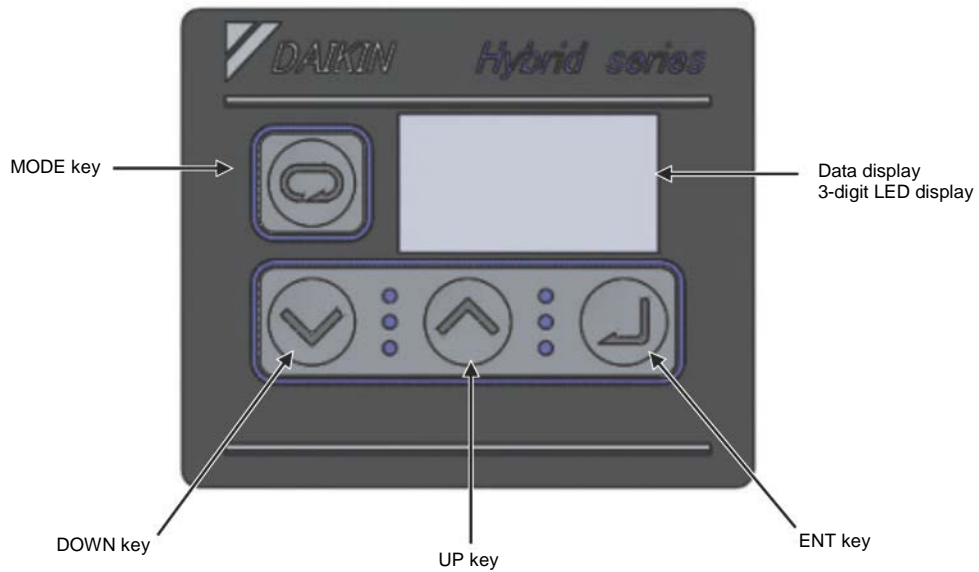

1 Explanation of Operation Keys



Name		Main Function
LED display		Displays monitor values for pressure, flow rate, etc., and the set values for each function. In the regular mode, it displays the current pressure.
MODE key		Used to select the regular mode or monitor mode.
Setting keys	DOWN key	Used to select monitor data, select parameter numbers and set parameter values. The UP key increments the value and the DOWN key decrements the value.
	UP key	
ENT key		Used to confirm selections for parameter numbers, parameter settings, etc.

3 Control Panel

2 Organization of Modes

Switch among modes by referring to the figure below.

For details on the operations, refer to the explanation of each mode.

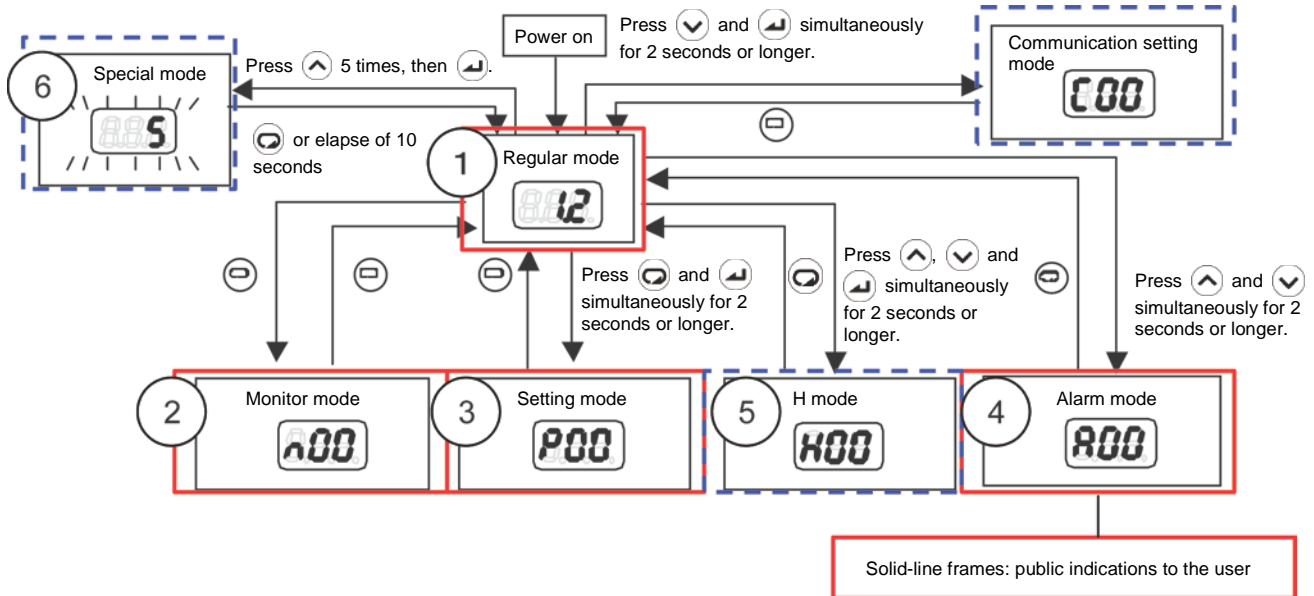

(1) Regular mode



This mode is automatically selected at powering on.

In this mode, the actual pressure is displayed in the normal status and the error code is displayed when an error occurs.

Status	Panel Indication	Details
Powering on		At powering on, all the LEDs flash momentarily.
Normal		In the normal status, the current pressure is displayed.
Stopped		Displayed when a stop command is in effect, and when the pressure is 0.15 MPa or lower.
AC failure		Displayed flashing in the AC failure (power supply interruption) status.
Occurrence of an alarm/warning		When an alarm/warning occurs, the corresponding alarm code or warning code is displayed.

(2) Monitor mode

The monitor mode enables checking of the value set with the pressure switch, the maximum set value for pressure, etc.

Monitor No.	Name	Resolution	Details
n00	Pressure switch set value	0.1 MPa	Displays the value set with the pressure switch.
		10 PSI	
n01	Pressure set value	0.1 MPa	Displays the current set value for pressure.
		10 PSI	
n02	Flow rate set value	0.1 L/min	Displays the current set value for flow rate.
n03	Flow rate	0.1 L/min	Displays the current flow rate.
n04	Latest alarm code	—	Displays the alarm code for the latest alarm. By pressing the  key, the current power-on count can also be checked.
n05	Motor rotation speed	$\times 10 \text{ min}^{-1}$	Displays the current rotation speed of the motor.
n06	Running status display	—	Displays the running status of the pump. While the pump is running, the segment dots repeatedly cycle from left to right. Example:  P-Q selection No. ON
n07	(Reserved for the system)	—	This is reserved for the system.
n08	(Reserved for the system)	—	This is reserved for the system.
n09	(Reserved for the system)	—	This is reserved for the system.
n10	Motor temperature	0.1°C	Displays the motor temperature.
n11	Radiator fin temperature	0.1°C	Displays the temperature of the radiator fins.
n12	Main circuit DC voltage	V	Displays the direct current voltage of the controller's main circuit. The voltage value is the supply power voltage multiplied by the square root of 2, and it varies depending on the running status.
n13	(Reserved for the system)	—	This is reserved for the system.
n14	(Reserved for the system)	—	This is reserved for the system.
n15	(Reserved for the system)	—	This is reserved for the system.
n16	(Reserved for the system)	—	This is reserved for the system.
n17	(Reserved for the system)	—	This is reserved for the system.
n18	(Reserved for the system)	—	This is reserved for the system.
n19	(Reserved for the system)	—	This is reserved for the system.
n20	Power-on count (lower digits)	Times	Displays the number of times the unit has been powered on after shipment from the factory. (On exceeding a count of 9,999, the value is cleared to 0.)
n21	Power-on count (upper digits)	$\times 1000$ times	
n22	Total operation time (minutes)	min	Displays the total operation time after shipment from the factory (time the motor is energized).
n23	Total operation time (hours)	h	
n24	Total operation time (thousands of hours)	$\times 1,000 \text{ h}$	
n25	Power consumption	0.01 kW	Displays the approximate power consumption.
n26	Interface PCB temperature	0.1°C	Displays the approximate temperature inside the controller.
n27	(Reserved for the system)	—	This is reserved for the system.

3 Control Panel

(3) Setting mode

The setting mode enables setting of the maximum pressure, the maximum flow rate, etc.

Item	Code	Name	Operation Range	Details
P00	DI_A	Start/stop signal switching	0: Runs at DIN0-ON 1: Runs at DIN0-OFF	Sets whether to run when the signal comes ON or run when the signal goes OFF.
P01	SW_L	Pressure switch	0 to 35.0 [MPa]	Sets the actuation pressure of the pressure switch. If set to "0", the pressure switch function is disabled.
			0 to 507 [$\times 10$ PSI]	
P02	T_SW	Pressure switch output delay time	0.00 to 9.99 [sec]	Sets the delay time for the pressure switch. Sets the delay time from when the pressure falls below the pressure switch actuation value to confirmation of the pressure drop.
P03	PSWH	Hold setting for pressure switch indication	0 to 2	When the "L63: Pressure switch actuation" warning has occurred, the "L63" indication displayed on the operation panel can be retained. It is also possible to record the "L63: Pressure switch actuation" warning in the alarm history, although it is not usually recorded there.
P04	DS_P	Unit selection of pressure	0: MPa indication 1: PSI indication	Enables selection of the display unit for pressures displayed on the panel.
P05	K_RT	(Reserved for the system)		
P06	D_RT	(Reserved for the system)		
P07	WN_M	(Reserved for the system)		
P08	AMIX	(Reserved for the system)		
P09	INIF	Initialize to default setting	0: Disable 1: Initialize P00 to P09 2: Initialize all parameters	Setting "1" or "2" then turning the power off and back on initializes parameters to their default values according to the setting made.
P10	L_TI	PQ integration time correction factor	1 to 500 [%]	Sets the integration time correction factor for PQ control. The smaller the value, the faster the response, but the more surge pressure occurs.
P11	M_VR	(Reserved for the system)		
P12	W_TM	(Reserved for the system)		

Item	Code	Name	Operation Range		Details	
P13	PL.0	Pressure setting	4 MPa specifications	1.5 to 4.0 [MPa]	Sets the target pressure. Only PL.0 is valid.	
				22 to 58 [×10 PSI]		
			7 MPa specifications	1.5 to 7.0 [MPa]		
				22 to 101 [× 10 PSI]		
	QL.0	Flow volume setting	14 L specifications	2.5 to 15.2 [L/min]		Sets the target flow rate. Only QL.0 is valid.
			25 L specifications	3.5 to 25.1 [L/min]		
30 L specifications			3.5 to 28.5 [L/min]			
P14 to P28		(Reserved for the system)	/			
P29	C_TM	(Reserved for the system)	/			
P30	DF_N	(Reserved for the system)	/			
P31	P_SN	Pressure sensor rated value	1 to 35 [MPa]		Sets the rated pressure of the pressure sensor. Normally, this setting does not need to be changed.	
P32	S_TM	Surgeless start time	0.01 to 9.99 [sec]		Sets the start-up time for a start with the motor at a stop. Increasing the value makes the start-up smoother and can prevent start-up surge, but it lengthens the response time at start-up.	
P33	L_IN	(Reserved for the system)	/			
P34	E_TM	(Reserved for the system)	/			
P35	DR_L	Dry operation judgment pressure	0.00 to 2.00 [MPa]		Sets the pressure condition for judging "E64: Dry operation error".	
			0 to 290 [PSI]			
P36	DR_T	Dry operation judgment time	0.01 to 9.99 [sec]		Sets the time for judging "E64: Dry operation error".	
P37	SM_R	(Reserved for the system)	/			
P38	P_DF	No detection zone of pressure switch	0.00 to 1.00 [MPa]		Sets the threshold value for detecting pressure recovery, after actuation of the pressure switch. This is set as a difference in the positive direction in relation to "P01: Pressure switch".	
			0 to 145 [× 10 PSI]			
P39	DO_S	Digital output selection	0 to 15		Sets the content of signals output from digital outputs and alarm outputs.	
P40	PL_D	(Reserved for the system)	/			
P41	PCMW	(Reserved for the system)	/			
P42	PCMM	(Reserved for the system)	/			

3 Control Panel

Item	Code	Name	Operation Range	Details
P43	QCMW	(Reserved for the system)		
P44	QCMM	(Reserved for the system)		
P45	AC_F	Cooling fan motor rotation speed	0: Always running (low speed) 1: Reserved for the system 2: Always running (high speed)	Switches the operation speed of the cooling fan.
P46	TVMJ	Maintenance implementation review enable/disable	0: Maintenance implementation review disabled 1: Maintenance implementation review enabled	Selects whether or not to issue an E66 (motor temperature rise due to pressure holding speed drop) alarm on occurrence of an L67 (pressure holding speed drop) warning while "H52: TVMR Maintenance request" is set to 1.
P47	RMOT	Alarm relay output maintenance notification enable/disable	0: Repetition of alarm relay ON/OFF upon occurrence of an L67 or E66 disabled 1: Repetition of alarm relay ON/OFF upon occurrence of an L67 or E66 enabled	Selects whether or not to repeat alarm relay ON/OFF on occurrence of an L67 (pressure holding speed drop) warning or an E66 (motor temperature rise due to pressure holding speed drop) alarm.
P48	T_SP	Reverse rotation warning judgment time	0.0 to 99.9 sec [sec]	Sets the judgment time for detection of the reverse rotation warning (L70).
P49	SWTM	Start acceptance wait time	0.0 to 99.9 sec [sec]	Sets the time from receiving a start command to actually initiating the start.
P50	OTUS	(Reserved for the system)		
P51	OTAM	(Reserved for the system)		
P52	OTAT	(Reserved for the system)		
P53	OTWN	(Reserved for the system)		
P54	OTWT	(Reserved for the system)		
P55	WN_L	Motor electronic thermal relay overload warning threshold value	101 to 110 [%]	Sets the threshold value for the motor electronic thermal relay overload warning. Setting 110% disables the function, meaning that no warning judgments are made.

[Relationship Between Alarm Outputs/Digital Outputs and Parameters]

Alarm Outputs (NO Contact Side)

Value of [P39: DO_S]	Status												
	No alarm												
	Under preparation to run	While Ready to run								Alarm has occurred			
		Value of [P47: RMOT]											
		0					1						
Pressure switch status normal and no L70	Pressure switch actuated and L70 has occurred	No L67 Warning			L67 Warning has occurred			Value of [P47: RMOT]					
		Pressure switch status normal and no L70	Pressure switch actuated and L70 has occurred	Pressure switch status normal	Pressure switch actuated and L70 has occurred	Pressure switch status normal	Pressure switch actuated	0	1				
							Other than E66 has occurred	E66 has occurred					
8-10, 12	Open	Closed	Open	Closed	Open	Closed	Open	Open	Switching in a 4-second cycle and open after elapse of 10 minutes				
11						Switching in a 4-second cycle and closed after elapse of 10 minutes	Switching in a 4-second cycle and open after elapse of 10 minutes						

Digital Outputs

P39	Status			
	Under preparation to run		Ready to run	
	No warning	Warning has occurred	No warning	Warning has occurred
8, 11	OFF		ON (ON status continues even if an alarm occurs or pressure switch is actuated.)	
9	ON	OFF	ON	OFF
10	OFF	ON	OFF	ON
12	ON		OFF (OFF status continues even if an alarm occurs or pressure switch is actuated.)	

(4) Alarm mode

The alarm mode enables checking of a history of up to 10 alarms that have occurred previously.

No.	Panel Indication	Display	Display Unit	Remarks
1	A*A	Alarm details	—	Alarm details
2	A*b	Power-on count	Number of times	Power-on count at occurrence of the alarm
3	A*r	Motor speed at alarm occurrence	10 min ⁻¹	Rotation speed of the motor at occurrence of the alarm
4	A*E	Effective motor current value	Arms	Effective current value of the motor at occurrence of the alarm
5	A*u	Main circuit DC voltage	V	DC voltage of the main circuit at occurrence of the alarm
6	A*c	Fin temperature	0.1°C	Fin temperature at occurrence of the alarm
7	A*L	(Reserved for the system)	—	This is reserved for the system.
8	A*F	(Reserved for the system)	—	This is reserved for the system.
9	A*h	Operation time (minutes)	min	Operation time at occurrence of the alarm
10	A*H	Operation time (hours)	h	
11	A*t	Operation time (thousands of hours)	1000 h	



Memo

- When the power-on count exceeds 999, it is cleared to 0.
- When the rotation speed at occurrence is a negative value, three dots light.

3 Control Panel

(5) Internal parameter mode

The internal parameter mode enables setting of internal parameters.

Select settings by using the  and  buttons.

Item	Code	Name	Operation Range	Details	Taking Effect
H00	—	Electrical current command rate [%]	—	Displays the commanded electrical current as a percentage of the maximum electrical current.	—
H01	—	Motor load rate [%]	—	Displays the load as a percentage of the motor current rating.	—
H02	—	Electrical current phase command value [0.1°]	—	Displays the electrical current phase command value.	—
H03	—	(Reserved for the system)	—	—	—
H04	—	(Reserved for the system)	—	—	—
H05	—	(Reserved for the system)	—	—	—
H06	—	(Reserved for the system)	—	—	—
H07	—	Changed items display	—	Displays parameters in the range P00 to P08 that have set values different from the factory defaults.	—
H08	—	Transition to alarm mode	—	Enables checking of the details of alarms that have occurred previously. Alarms from the most recent to the tenth previous are displayed. Refer to the alarm mode display.	—
H09	L_KP	(Reserved for the system)	—	—	—
H10	V_KP	(Reserved for the system)	—	—	—
H11	V_KI	(Reserved for the system)	—	—	—
H12	—	(Reserved for the system)	—	—	—
H13	L_IN	(Reserved for the system)	—	—	—
H14	AC_M	(Reserved for the system)	—	—	—
H15	VR_Q	(Reserved for the system)	—	—	—
H16	QMIN	Restriction value for minimum rotation speed command	0 to 2000 [min ⁻¹]	Sets the minimum limit value for rotation speed in the pressure control range when computing power deviation in PQ control calculations. A certain level of responsiveness can be ensured even if the rotation speed falls below the value set for this parameter. Setting a larger value ensures responsiveness at lower speeds.	When changed
H17	PMIN	Restriction value for minimum pressure	0 to 2000 [kPa]	Sets the minimum pressure for deviation calculations. A certain level of responsiveness can be ensured even if the pressure falls below the value set for this parameter.	When changed
H18	PS_D	Pressure sensor correction factor	0 to 10 [0.1%]	Corrects the pressure value at the maximum input voltage.	When changed
H19	—	(Reserved for the system)	—	—	—

Item	Code	Name	Operation Range	Details	Taking Effect
H20	FLOC	Lock for panel setting change	0: Disabled 1: Enabled	Restricts the set parameters that can be edited. When "1: Enabled" is set, editing of parameters P01 to P08 is prohibited and their settings are protected.	When changed
H21	—	(Reserved for the system)	—	—	—
H22	—	(Reserved for the system)	—	—	—
H23	—	(Reserved for the system)	—	—	—
H24	—	(Reserved for the system)	—	—	—
H25	L_TI (H_TI)	PQ integration time correction factor	1 to 500 [%]	Sets the integration gain correction factor for PQ control. The smaller the value the faster response, but the more surge pressure occurs. L_TI can be set only when full-time combination flow is selected.	When changed
H26	H_KP	(Reserved for the system)	—	—	—
H27	CH_M	(Reserved for the system)	—	—	—
H28	U_TM	(Reserved for the system)	—	—	—
H29	SP_Q	(Reserved for the system)	—	—	—
H30	UP_Q	(Reserved for the system)	—	—	—
H31	D_TM	(Reserved for the system)	—	—	—
H32	LM_R	(Reserved for the system)	—	—	—
H33	DREV	(Reserved for the system)	—	—	—
H34	SP_W	(Reserved for the system)	—	—	—
H35	LM2R	(Reserved for the system)	—	—	—
H36	CR_M	(Reserved for the system)	—	—	—
H37	L_ER	(Reserved for the system)	—	—	—
H38	PI_Z	(Reserved for the system)	—	—	—
H39	PI_G	(Reserved for the system)	—	—	—
H40	QI_Z	(Reserved for the system)	—	—	—
H41	QI_G	(Reserved for the system)	—	—	—
H42	PO_Z	(Reserved for the system)	—	—	—
H43	PO_G	(Reserved for the system)	—	—	—
H44	QO_Z	(Reserved for the system)	—	—	—
H45	QO_G	(Reserved for the system)	—	—	—
H46	Q_EV	(Reserved for the system)	—	—	—
H47	AM_T	Alarm measurement: Sampling time	0 to 999	Alarm measurement: Sampling time	At power ON
H48	AMD1	Alarm measurement: Data 1	0 to 999	Alarm measurement: Data 1	
H49	AMD2	Alarm measurement: Data 2	0 to 999	Alarm measurement: Data 2	
H50	AMD3	Alarm measurement: Data 3	0 to 999	Alarm measurement: Data 3	
H51	DHSL	L67: Holding pressure speed drop warning judgment Pressure offset	0 to 9.99 [0.01 MPa]	Sets the pressure threshold value for Warning L67: Holding pressure speed drop warning judgment pressure offset.	When changed

3 Control Panel

Item	Code	Name	Operation Range	Details	Taking Effect
H52	TVMR	Maintenance request	0: No request 1: Request issued	When E66 (motor temperature rise due to pressure holding speed drop) occurs, "1" is set. If L67 (pressure holding speed drop) has not occurred within 30 seconds after starting the motor, "0" is set.	(When changed)
H53	MTLH	Motor abnormal temperature threshold	0 to 85.0 [°C]	Setting "0" disables the set value and the default set value is used as the threshold.	At power ON
H54	RT_O	Reverse rotation warning judgment pressure	0.00 to 9.99 MPa	Sets the pressure for judging the reverse rotation warning. When "0" is set, reverse rotation warning judgment is disabled.	When changed
H55	LG_L	Constant horsepower command	10 to 200%	Sets a percentage relative to the horsepower curve's reference value.	When changed
H56	LGOL	Constant horsepower command offset	0 to 450 min ⁻¹	Sets the offset for the commanded rotation speed at the maximum pressure point.	When changed

3 Operating Procedure

3.1 Monitor Mode Operations

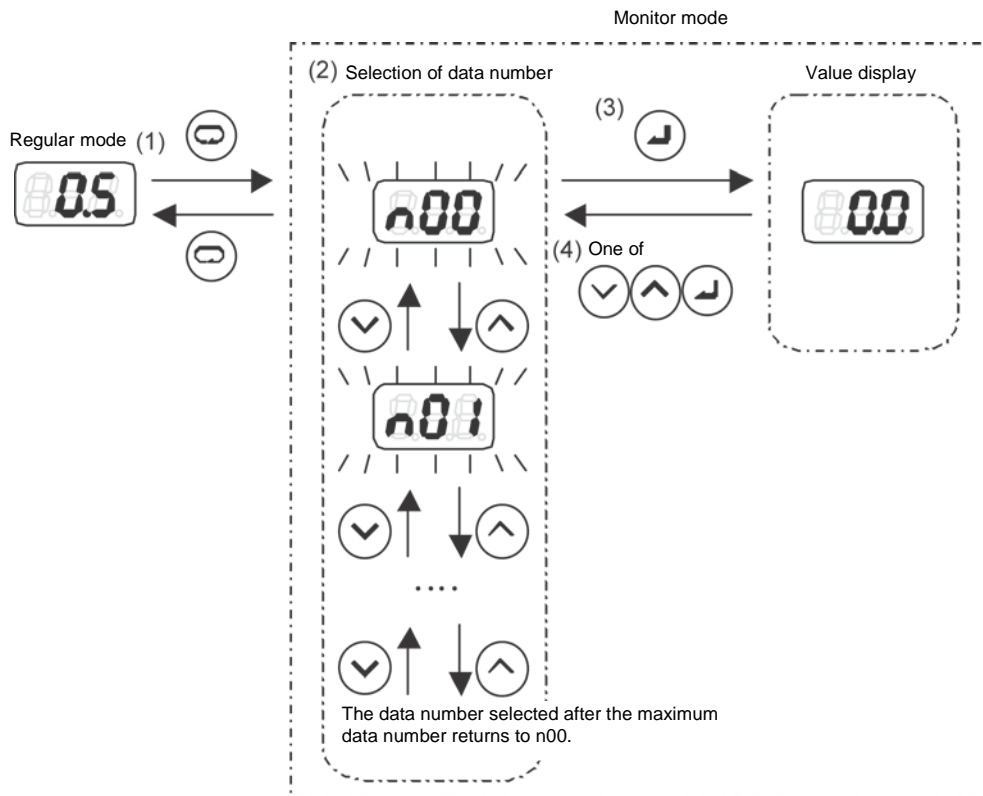

- 1) Press the key in the regular mode.
The mode will switch to the monitor mode.
- 2) Select the data number to be displayed by using the key or key.
During data number selection, the display will flash.
- 3) Confirm the data number to be displayed by using the key.
During data number selection, the display will flash.
- 4) Return to data number selection with , or .

3 Control Panel

3.2 Setting Mode Operations

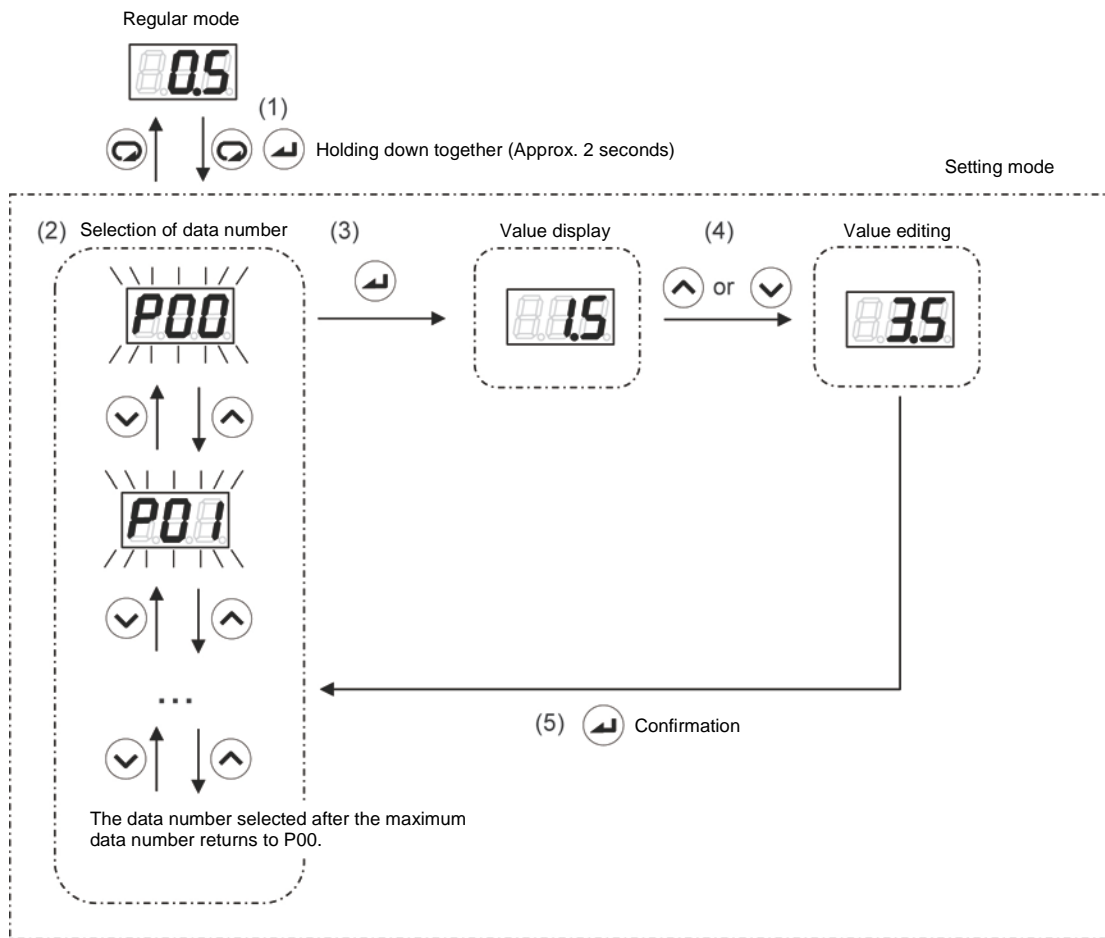

- 1) Hold down the and keys together in the regular mode.
After about 2 seconds, the mode will switch to the setting mode.
- 2) Select the data number to be displayed by using the key or key.
During data number selection, the display will flash.
- 3) Confirm the data number by pressing the key.
The value for the selected data number will be displayed.
- 4) Change the set value by incrementing or decrementing it with the and keys.
- 5) Confirm the set value and return to data number selection by pressing the key.

3.3 PQ Selection Parameters

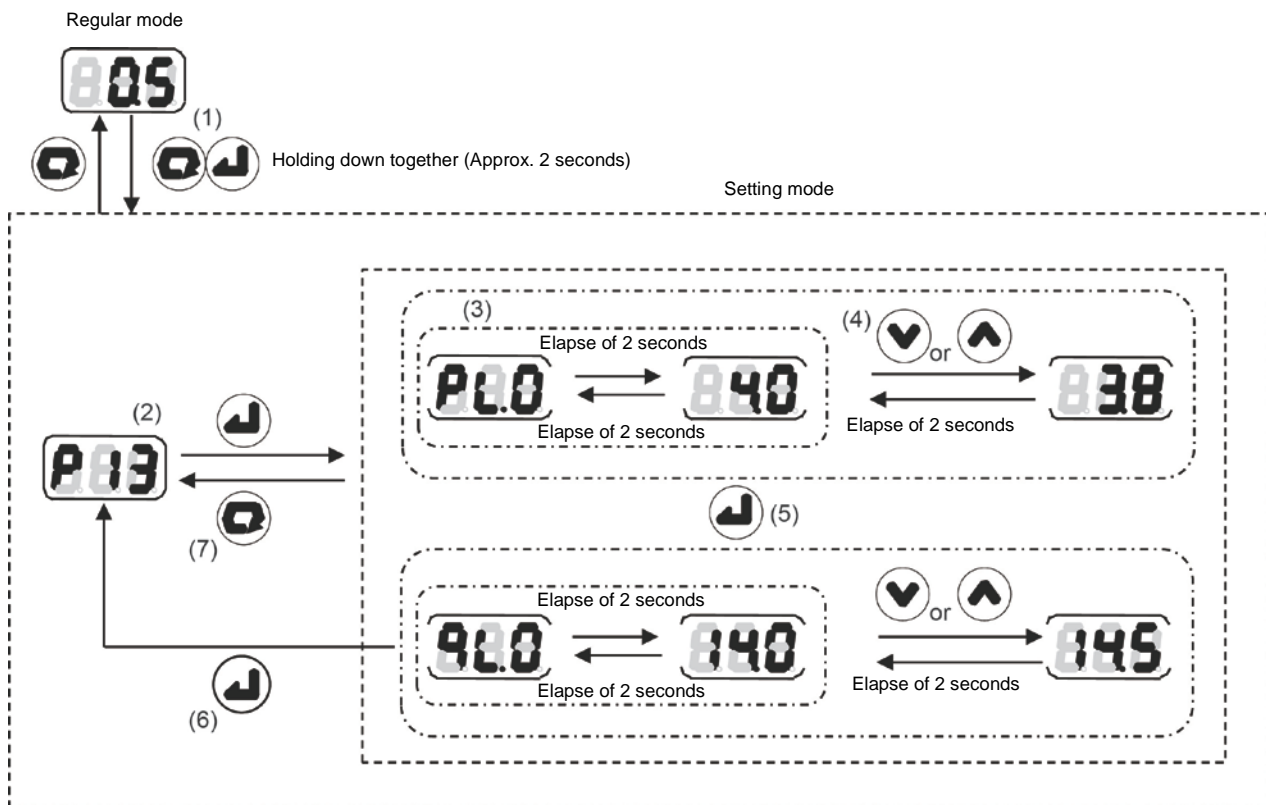

- 1) Hold down the and keys together in the regular mode. After about 2 seconds, the mode will switch to the setting mode.
- 2) Select P13 with the or key, and confirm by pressing the key.
- 3) The set values for pressure and flow rate in the PQ selection parameters will be displayed alternately at approximately 2-second intervals.

• Relationship between data display and parameters







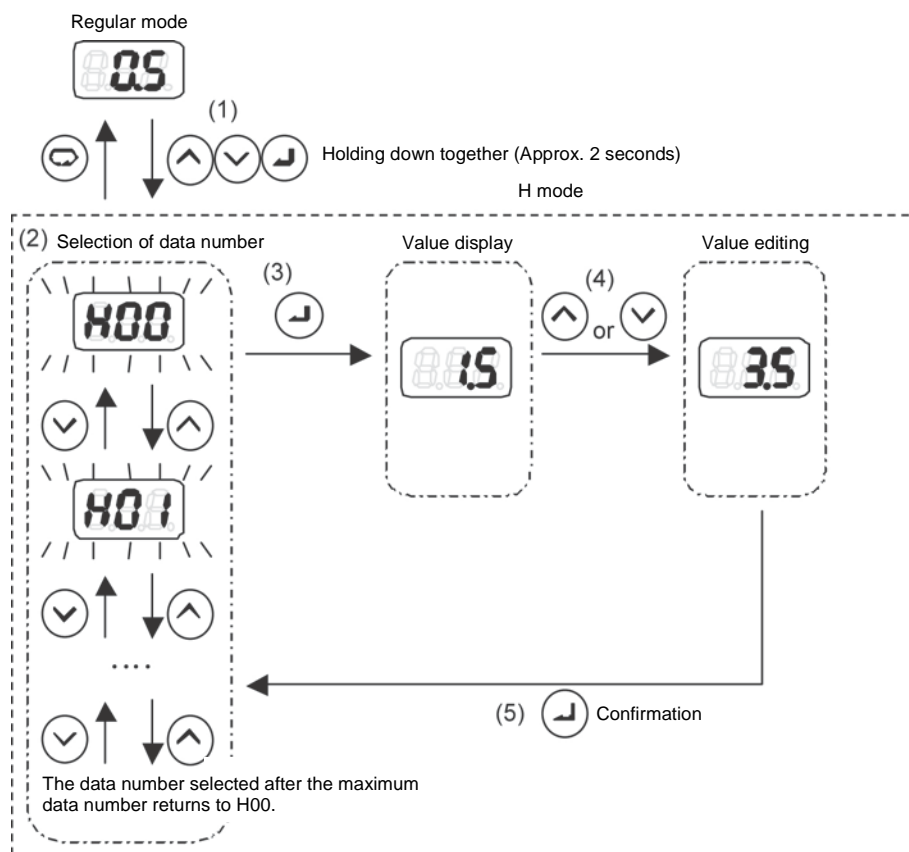

Display Order	Display *1	Parameter Name
1		Pressure setting
2		Flow rate setting

- 4) Change the set value by incrementing or decrementing it with the and keys. The data code will be displayed approximately 2 seconds after a set value has been changed.
- 5) Confirm the set value with the key. The next data code will be displayed.
- 6) Pressing the key will switch the display to the data number selection screen. Parameters whose values have been changed up until that time will retain the changed values.
- 7) Setting the flow rate setting “QL.0” will switch the display to the data number selection screen.

3 Control Panel

3.4 H Mode



- 1) Hold down the ,  and  keys together in the regular mode.
After about 2 seconds, the mode will switch to the H mode.
- 2) Select the data number to be displayed by using the  key or  key.
During data number selection, the display will flash.
- 3) Confirm the data number by pressing the  key.
The value for the selected data number will be displayed.
- 4) Change the set value by incrementing or decrementing it with the  and  keys.
- 5) Confirm the set value and return to data number selection by pressing the  key.

3.5 Alarm Mode

The alarm mode enables checking of up to 10 alarms in the history of alarms that have occurred in the past. For details on the displayed alarm codes, refer to 4.4 Error Code List.

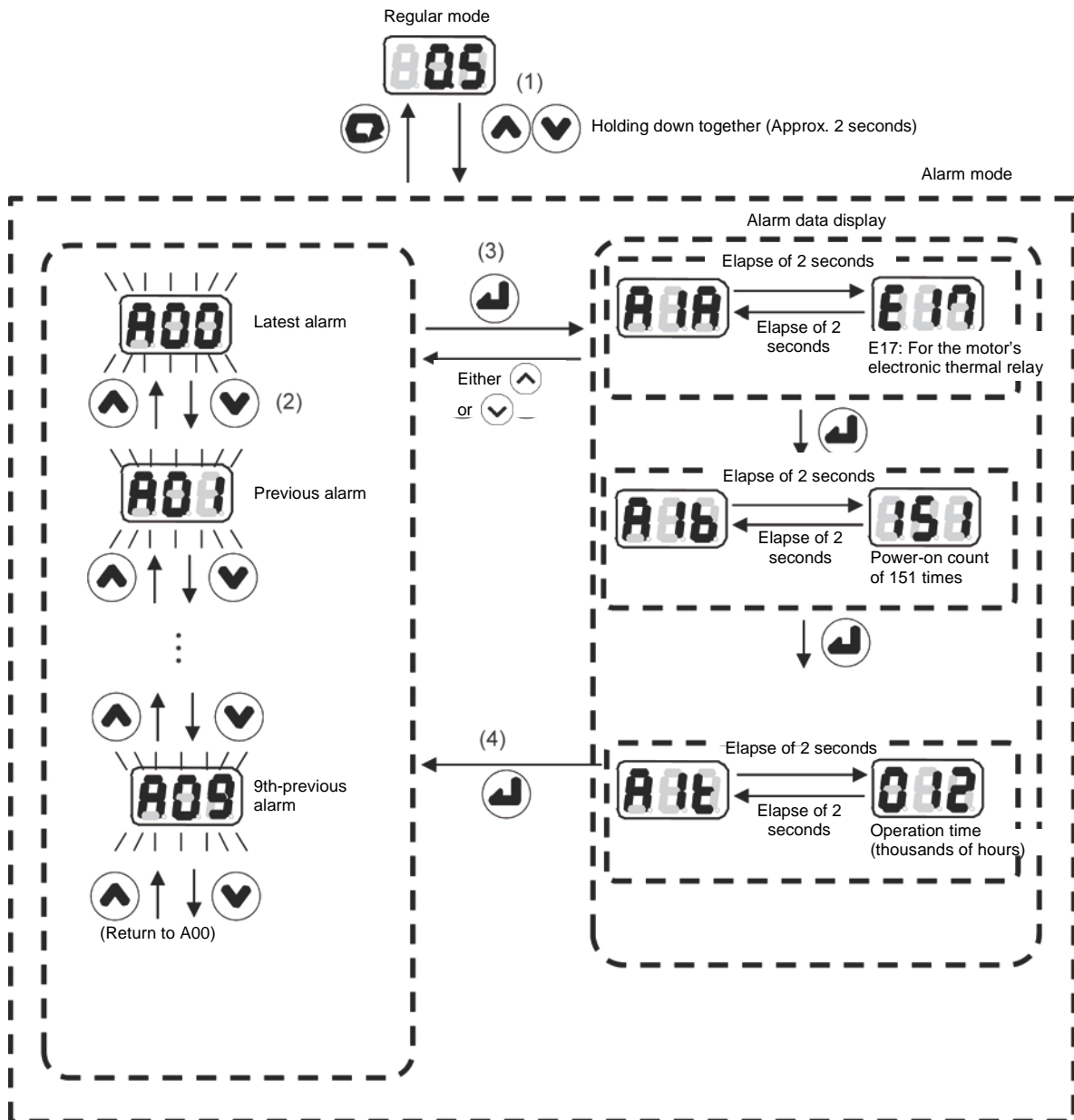

- 1) Hold down the and keys together in the regular mode.
After about 2 seconds, the mode will switch to the alarm mode.
- 2) Select the alarm history number to be displayed by using the or key.
During alarm history number selection, the display will flash.
A00 is the latest alarm, with older alarm displayed in sequence in this order: A01 → A02 →.
- 3) Confirm the alarm history number with the key.
The corresponding alarm code and the data upon occurrence of the alarm concerned will be displayed alternately.
- 4) Return to the alarm history number selection by pressing the , or key.

3 Control Panel

3.6 Special Mode

The special mode enables the following operations.

Function	Details
Software version number check	Enables checking of the software version number.
Alarm history clear	Enables clearing of the alarm history.

[Software Version No. Check]

The software version number can be checked from the panel by following the operation below.

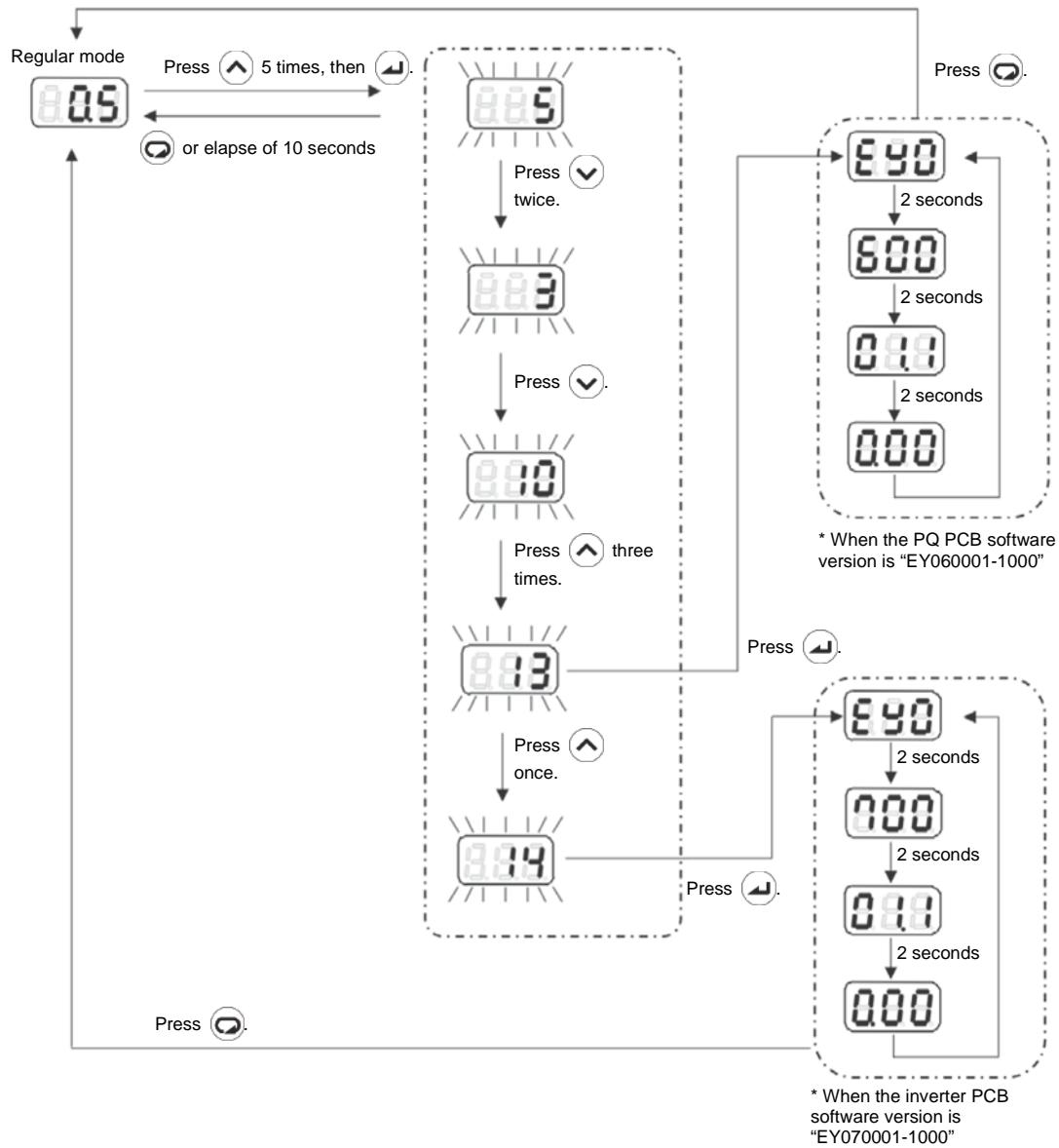

[Alarm History Clear]

The alarm history can be cleared by following the operation below.

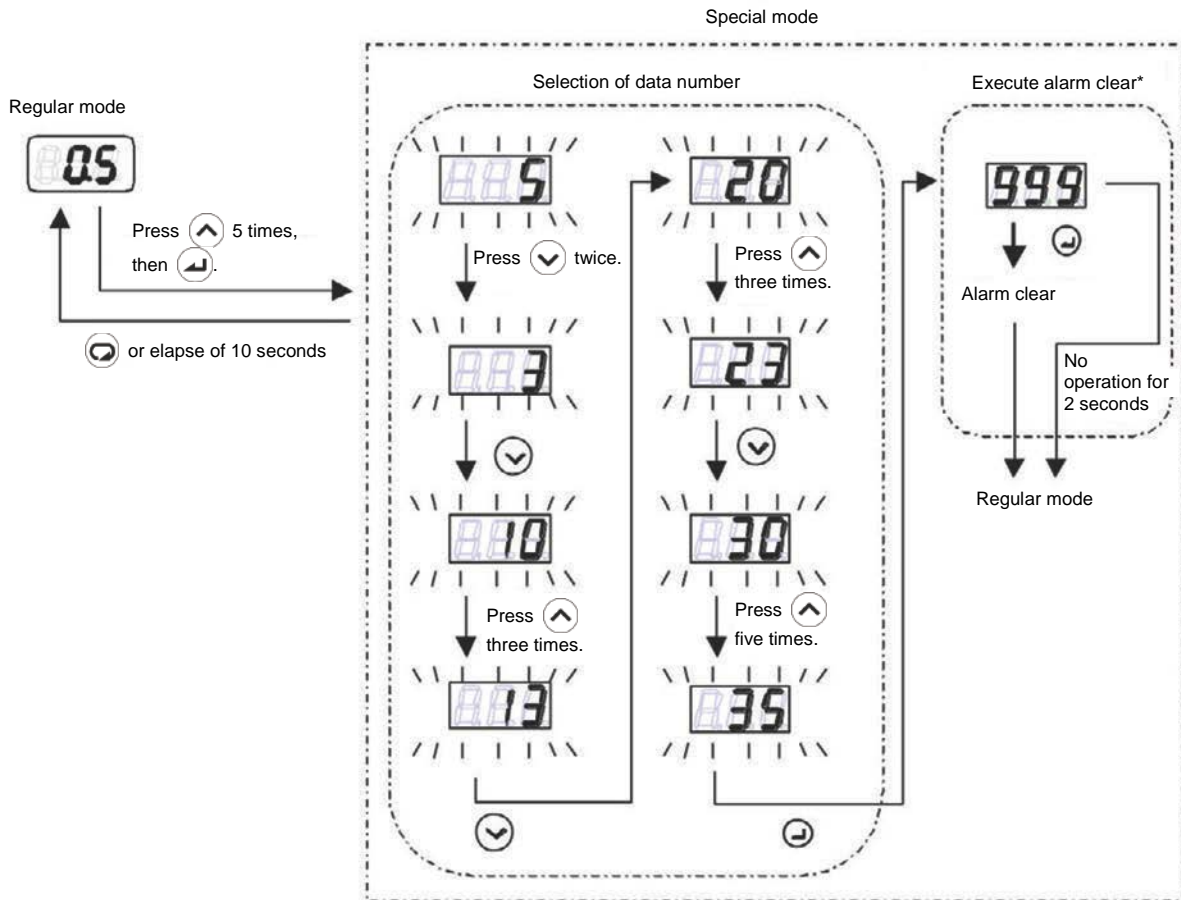

* If no operation is carried out for 2 seconds on the alarm clear execution screen, the mode will switch to the regular mode without clearing alarms.

4 Troubleshooting

1 Operating Procedure for Service

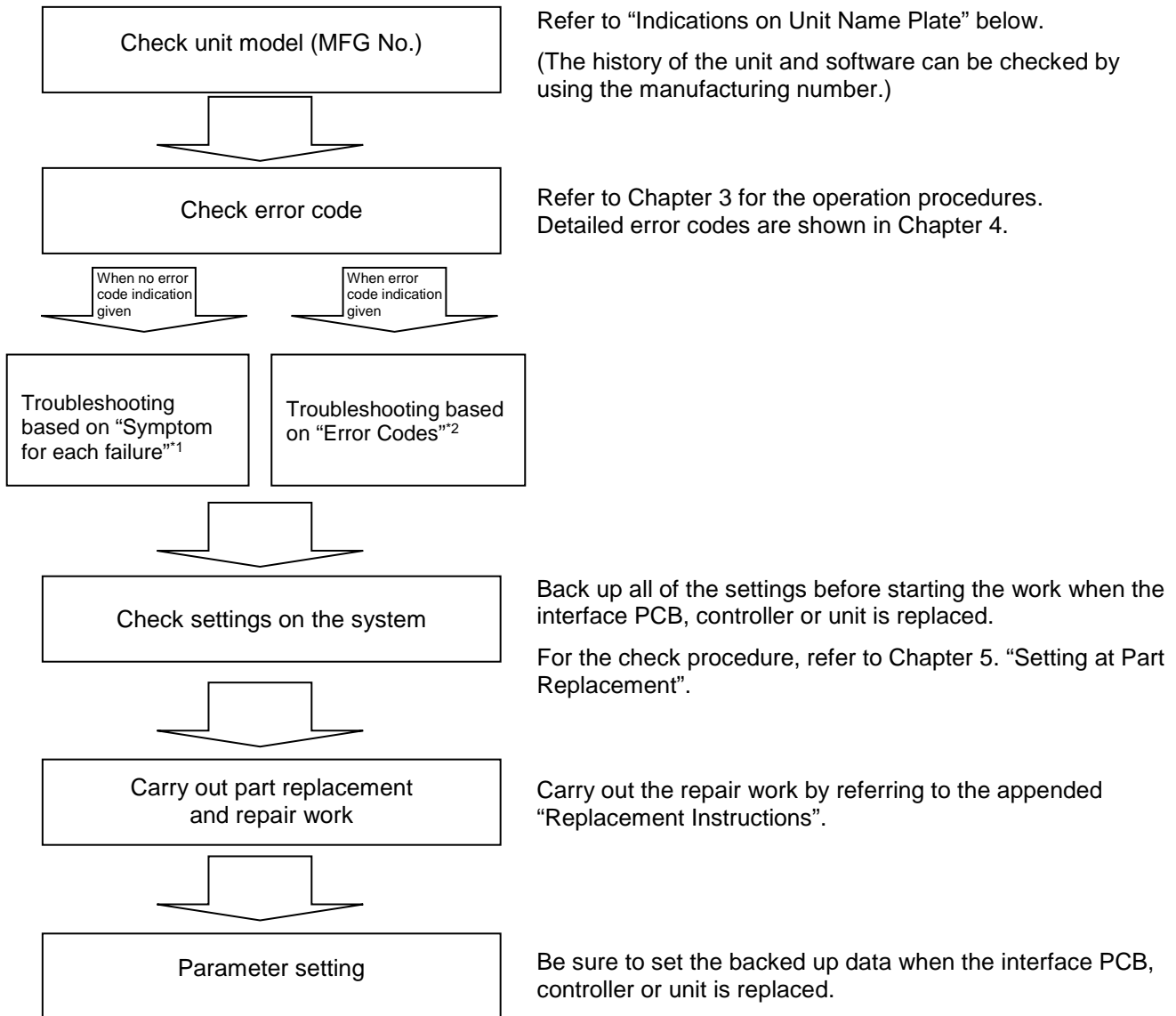

Indications on Unit Name Plate

The progressive number and year/month of manufacture can be identified by referring to the MFG No. indicated on the unit name plate on the front face of the unit.

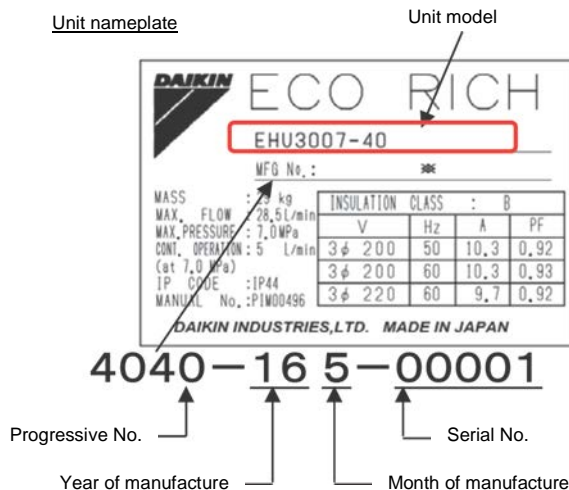

2 Preparation for Investigation of Alarms

Check the controller display with power on.

- Pressure indication (MPa)
- “StP” indication
- Alarm indication (E)
- Warning indication (L)

Switch the “operation mode” to “monitor mode” and check details.

Item	Description	Display Unit	Monitor Value
n00	Pressure switch set value	[MPa] or [×10 PSI]	
n01	Max. pressure set value	[MPa] or [×10 PSI]	
n02	Max. flow volume set value	L/min	
n03	Discharge volume	L/min	
n04	Latest alarm code/Power-on counts		/
n05	Motor rotation speed	×10 min ⁻¹	
n10	Motor temperature	°C	
n11	Radiator fin temperature	°C	
n12	Main circuit DC voltage	V	

Switch the “operation mode” to “special mode” and check the software version.

- Four indications are repeated continuously at two-second intervals.
- “EY0” and “three indications with different decimal point” are displayed. Record all indications.
- The controller has two types of software installed (one is for the interface PCB and the other is for the power PCB)

Check it by referring to the operating procedure in the special mode.

Models	Decimal Point Position		
	Third Digit	Second Digit	None
EYO			

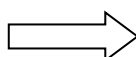

Example: For software model “EY060001-1000”

EYO	0.00	01.1	600
-----	------	------	-----

Explanation of the model

For “EY060001-1000”

- EY: Basic model
- 06: Software type
- 0001: Software No.
- 1000: Revision

4 Troubleshooting

Switch the “operation mode” to “setting mode” and check settings.

Item	Description	Display Unit	Set Value
P00	Start/stop signal switching	--	
P01	Pressure switch	MPa	
P02	Pressure switch delay time	Second	
P03	Hold setting for pressure switch indication	--	
P04	Unit selection of pressure	--	
P10	PQ integration time correction factor	%	
P13	PL.0 pressure setting	MPa	
P13	QL.0 flow volume setting	L/min	
P31	Pressure sensor rated value	MPa	
P32	Surgeless start time	Second	
P35	Dry operation judgment pressure	MPa	
P36	Dry operation judgment time	Second	
P38	No detection zone of pressure switch	MPa	
P39	Digital output selection	--	
P45	Cooling fan motor rotation speed	--	
P46	Maintenance implementation review enable/disable	--	
P47	Alarm relay maintenance notification	--	
P48	Reverse rotation warning judgment time	Second	
P49	Start acceptance wait time	Second	
P55	Electronic thermal relay threshold value	%	

Switch the “operation mode” to “alarm mode” and read alarm information.

Item	Alarm information	Power-on count	Rotation speed at alarm occurrence	Motor current effective value	Main circuit voltage	Radiator fin temperature	Reserved for the system	Reserved for the system	Operation time (minutes)	Operation time (hours)	Operation time (thousands of hours)
Panel indication	A*A	A*b	A*r	A*E	A*u	A*c	A*L	A*F	A*h	A*H	A*t
A00											
A01											
A02											
A03											
A04											
A05											
A06											
A07											
A08											
A09											

1 “” represents a numeric value from 0 to 9 indicating the alarm history.

*2 A00 is the latest alarm.

4 Troubleshooting

3 Troubleshooting by Each Symptoms

3.1 List of Symptoms

No.	Symptom	Countermeasures	Ref. Page
1	No indication on the display	<ul style="list-style-type: none">• Check if the circuit breaker has tripped.• Check the supply power voltage.• Replace the interface PCB.	P.39
2	No indication on the display and can't switch on	<ul style="list-style-type: none">• Check the connections of the communications harness.• Check the connections of the power supply relay harness.• Check the DCL harness.• Replace the power PCB.• Replace the controller.	P.40
3	Cannot increase pressure	<ul style="list-style-type: none">• Correct the start/stop signal setting.• Correct the pressure setting.• Supply hydraulic oil.• Replace the pressure sensor.• Replace the motor pump.	P.41
4	Unstable pressure	<ul style="list-style-type: none">• Check clogging of the throttle with foreign matter.• Set a gain suitable for the circuit.• Replace the motor pump.	P.42
5	Excessive pulsation	<ul style="list-style-type: none">• Adjust the rotation speed of the motor pump.• Replace the discharge port's check valve.• Replace the motor pump.	P.43
6	Abnormal noise observed	<ul style="list-style-type: none">• Check if any mounting points are loose.• Replace the motor pump.	P.44
7	Low flow volume	<ul style="list-style-type: none">• Check the flow volume setting.• Clean the suction strainer.• Increase the size of the discharge pipe.	P.45
8	Circuit breaker trips	<ul style="list-style-type: none">• Find the location of the current leakage and take appropriate action.• Check the power supply line from the main machine.• Replace the motor pump and controller.	P.46

3.2 Troubleshooting by Each Symptoms

Control panel display No display	No indication on the display
--	-------------------------------------

1 Applicable model	5 Troubleshooting	
EHU1404-40-* EHU2504-40-* EHU2507-40-* EHU3007-40-*	Diagnosis	Countermeasures
2 Error detection method	<pre> graph TD A{Circuit breaker tripped?} -- YES --> C1[Go to "Circuit breaker trips".] A -- NO --> B{Unit running?} B -- YES --> C2[Interface PCB failure → Replace PCB Refer to: Instructions 14] B -- NO --> D{Power supply voltage within specifications?} D -- YES --> C3[Go to "No display" → Can't switch on.] D -- NO --> C4[Error of the supply power line] </pre> <p style="font-size: small;">Power supply specifications AC 200 ±10% 50/60 Hz AC 220 ±10% 60 Hz</p>	
X		
3 Error confirmation condition		
X		
4 Probable causes		
<ul style="list-style-type: none"> • Power supply error • Short circuit of power supply relay harness • Motor wire ground fault/short • Power PCB failure • Interface PCB failure 		

4 Troubleshooting

Control panel display No display	No indication on the display → Can't switch on
--	---

1 Applicable model	5 Troubleshooting	
EHU1404-40-* EHU2504-40-* EHU2507-40-* EHU3007-40-*	Diagnosis	Countermeasures
2 Error detection method	<pre> graph TD Start[Turn the power off, wait at least 5 minutes, then open the controller's cover.] --> D1{Power PCB and interface PCB connected?} D1 -- NO --> C1[Connect power supply communication harness between power and interface PCBs Refer to: Instructions 15] D1 -- YES --> D2{Power supply harness connected?} D2 -- NO --> C2[Connect power supply relay harness Refer to: Instructions 15] D2 -- YES --> D3{DCL harness connected?} D3 -- NO --> C3[Connect DCL harness and DCL shorting harness Refer to: Instructions 15] D3 -- YES --> C4[Replace power PCB Refer to: Instructions 15] </pre>	
X		
3 Error confirmation condition		
X		
4 Probable cause	<ul style="list-style-type: none"> • Harness failure or faulty connection • Power supply communication harness • Power supply relay harness • DCL harness • Power PCB failure 	

Control panel display Pressure indication	Cannot increase pressure
---	---------------------------------

1 Applicable model	5 Troubleshooting	
EHU1404-40-* EHU2504-40-* EHU2507-40-* EHU3007-40-*	Diagnosis	Countermeasures
2 Error detection method		
3 Error confirmation condition		
4 Probable causes	<ul style="list-style-type: none"> • Incorrect start/stop signal setting • Increasing leakage volume at main machine • Low hydraulic oil level in tank • Pump volumetric efficiency degraded • Power PCB failure 	

4 Troubleshooting

Control panel display Pressure indication	Unstable pressure
---	--------------------------

1 Applicable model	5 Troubleshooting	
EHU1404-40-* EHU2504-40-* EHU2507-40-* EHU3007-40-*	Diagnosis	Countermeasures
2 Error detection method	<pre> graph TD A[Adjust variable throttle] --> B{Pressure stable?} B -- YES --> C[Rotation speed decrease due to clogging of throttle with foreign matter] B -- NO --> D[Increase response gain (P10) setting] D --> E{Pressure stable?} E -- YES --> F[Faulty gain setting for in relation to load capacity at main machine] E -- NO --> G{Start/stop signal used?} G -- YES --> H[Disconnect start/stop signal line and change start/stop signal logic] G -- NO --> I[Replace motor pump] H --> J{Pressure stable?} J -- YES --> K[Chattering of start/stop signal is the cause] J -- NO --> I </pre>	
3 Error confirmation condition		
4 Probable causes		
<ul style="list-style-type: none"> • Speed drop due to foreign matter • Gain setting fault • Start/stop signal chattering • Motor pump fault (insufficient motor torque or pump torque rise) • Power PCB failure 		

Control panel display Pressure indication	Excessive pulsation
---	----------------------------

1 Applicable model	5 Troubleshooting	
EHU1404-40-* EHU2504-40-* EHU2507-40-* EHU3007-40-*		
2 Error detection method	Diagnosis	Countermeasures
X	<pre> graph TD A{Rotation speed = 300 min⁻¹?} -- YES --> B[Adjust rotation speed Refer to: Instructions 16] A -- NO --> C{Check valve at the discharge port?} C -- YES --> D[Resonance with check valve (1) Recommended check valve used? Model: HDIN-T03-005-432 (2) Change position] C -- NO --> E[Replace motor pump Refer to: Instructions 2, 3] </pre>	<p>Adjust rotation speed Refer to: Instructions 16</p> <p>Resonance with check valve (1) Recommended check valve used? Model: HDIN-T03-005-432 (2) Change position</p> <p>Replace motor pump Refer to: Instructions 2, 3</p>
3 Error confirmation condition	X	
4 Probable causes	<ul style="list-style-type: none"> • Faulty rotation speed adjustment • Resonance with check valve • Pump fault 	

4 Troubleshooting

Control panel display Pressure indication	Abnormal noise observed
---	--------------------------------

1 Applicable model	5 Troubleshooting	
EHU1404-40-* EHU2504-40-* EHU2507-40-* EHU3007-40-*	Diagnosis	Countermeasures
2 Error detection method	<pre> graph TD A{Abnormal noise from DC fan?} -- YES --> B[Check for foreign matter entrapped in fan rotating parts] A -- NO --> C{Noise observed when rotation speed changes?} C -- YES --> D[Check for looseness of unit fixing bolts] C -- NO --> E{Noise observed at holding pressure?} E -- YES --> F[Replace motor pump Refer to: Instructions 2, 3] E -- NO --> G[Inverter-specific high-frequency noise (normal)] </pre>	
X		
3 Error confirmation condition		
X		
4 Probable causes		
<ul style="list-style-type: none"> • Looseness of unit fixing bolts • Foreign matter entrapped in fan • Inverter noise • Motor pump trouble 		

Control panel display Pressure indication	Low flow rate
---	----------------------

<p>1 Applicable model</p> <p>EHU1404-40-* EHU2504-40-* EHU2507-40-* EHU3007-40-*</p> <p>2 Error detection method</p> <p style="text-align: center;">X</p> <p>3 Error confirmation condition</p> <p style="text-align: center;">X</p> <p>4 Probable causes</p> <ul style="list-style-type: none"> • Flow rate setting error • Throttle adjustment fault • Decrease in efficiency of the pump, volumetric • Power supply voltage drop • Increase in pressure loss 	<p>5 Troubleshooting</p> <table border="1" style="width: 100%;"> <thead> <tr> <th style="width: 70%;">Diagnosis</th> <th style="width: 30%;">Countermeasures</th> </tr> </thead> <tbody> <tr> <td style="vertical-align: top;"> <pre> graph TD A{Flow rate setting correct?} -- NO --> B[Flow rate setting incorrect Change P13 (max. flow rate setting) to desired value in setting mode] A -- YES --> C[Check flow rate at n03 (flow rate indication) in monitor mode] C --> D{Flow rate matches setting?} D -- YES --> E{Check holding pressure rotation speed} D -- NO --> F[Check power supply voltage Refer to: Instructions 13] E -- Out of normal range --> G[Reconsider appropriate flow rate and make the right setting] E -- Within normal range --> H[Adjust minimum rotation speed Refer to: Instructions 16] H -- Out of normal range --> I{Check holding pressure rotation speed} I -- YES --> J[Replace motor pump Refer to: Instructions 2, 3] I -- NO --> K{Power supply voltage within stipulated value?} F --> K K -- YES --> L[Flow rate drop due to pipeline pressure loss Increase size of discharge piping] K -- NO --> M[Flow rate drop due to insufficient voltage] </pre> </td> <td style="vertical-align: top;"> <p>Flow rate setting incorrect Change P13 (max. flow rate setting) to desired value in setting mode</p> <p>Reconsider appropriate flow rate and make the right setting</p> <p>Replace relief valve Refer to: Instructions 4</p> <p>Replace motor pump Refer to: Instructions 2, 3</p> <p>Flow rate drop due to insufficient voltage</p> <p>Flow rate drop due to pipeline pressure loss Increase size of discharge piping</p> </td> </tr> </tbody> </table>	Diagnosis	Countermeasures	<pre> graph TD A{Flow rate setting correct?} -- NO --> B[Flow rate setting incorrect Change P13 (max. flow rate setting) to desired value in setting mode] A -- YES --> C[Check flow rate at n03 (flow rate indication) in monitor mode] C --> D{Flow rate matches setting?} D -- YES --> E{Check holding pressure rotation speed} D -- NO --> F[Check power supply voltage Refer to: Instructions 13] E -- Out of normal range --> G[Reconsider appropriate flow rate and make the right setting] E -- Within normal range --> H[Adjust minimum rotation speed Refer to: Instructions 16] H -- Out of normal range --> I{Check holding pressure rotation speed} I -- YES --> J[Replace motor pump Refer to: Instructions 2, 3] I -- NO --> K{Power supply voltage within stipulated value?} F --> K K -- YES --> L[Flow rate drop due to pipeline pressure loss Increase size of discharge piping] K -- NO --> M[Flow rate drop due to insufficient voltage] </pre>	<p>Flow rate setting incorrect Change P13 (max. flow rate setting) to desired value in setting mode</p> <p>Reconsider appropriate flow rate and make the right setting</p> <p>Replace relief valve Refer to: Instructions 4</p> <p>Replace motor pump Refer to: Instructions 2, 3</p> <p>Flow rate drop due to insufficient voltage</p> <p>Flow rate drop due to pipeline pressure loss Increase size of discharge piping</p>
Diagnosis	Countermeasures				
<pre> graph TD A{Flow rate setting correct?} -- NO --> B[Flow rate setting incorrect Change P13 (max. flow rate setting) to desired value in setting mode] A -- YES --> C[Check flow rate at n03 (flow rate indication) in monitor mode] C --> D{Flow rate matches setting?} D -- YES --> E{Check holding pressure rotation speed} D -- NO --> F[Check power supply voltage Refer to: Instructions 13] E -- Out of normal range --> G[Reconsider appropriate flow rate and make the right setting] E -- Within normal range --> H[Adjust minimum rotation speed Refer to: Instructions 16] H -- Out of normal range --> I{Check holding pressure rotation speed} I -- YES --> J[Replace motor pump Refer to: Instructions 2, 3] I -- NO --> K{Power supply voltage within stipulated value?} F --> K K -- YES --> L[Flow rate drop due to pipeline pressure loss Increase size of discharge piping] K -- NO --> M[Flow rate drop due to insufficient voltage] </pre>	<p>Flow rate setting incorrect Change P13 (max. flow rate setting) to desired value in setting mode</p> <p>Reconsider appropriate flow rate and make the right setting</p> <p>Replace relief valve Refer to: Instructions 4</p> <p>Replace motor pump Refer to: Instructions 2, 3</p> <p>Flow rate drop due to insufficient voltage</p> <p>Flow rate drop due to pipeline pressure loss Increase size of discharge piping</p>				

4 Troubleshooting

Control panel display No display	Circuit breaker trips
--	------------------------------

1 Applicable model	5 Troubleshooting	
EHU1404-40-* EHU2504-40-* EHU2507-40-* EHU3007-40-*	Diagnosis	Countermeasures
2 Error detection method	<pre> graph TD Q1{Is the circuit breaker capacity appropriate?} -- NO --> C1[Make the circuit breaker capacity appropriate. * Capacity EHU1404-40-* / 15A EHU2504-40-* / 15A EHU2507-40-* / 15A EHU3007-40-* / 15A] Q1 -- YES --> Q2{Earth leakage circuit breaker tripped?} Q2 -- YES --> C2[Find location of current leak and take appropriate action or lower leak sensitivity (Excessive leakage current)] Q2 -- NO --> B1[Short circuit check Refer to: Instructions 13] B1 --> Q3{Customer's power supply short circuited} Q3 -- YES --> C3[Customer's power supply abnormal] Q3 -- NO --> Q4{Motor short circuit} Q4 -- YES --> C4[Replace motor Refer to: Instructions 2, 3] Q4 -- NO --> C5[Replace power PCB Refer to: Instructions 14] C5 --> C6[Replace controller Refer to: Instructions 1] </pre>	
3 Error confirmation condition		
4 Probable causes	<ul style="list-style-type: none"> • Excessive leakage current • Motor short circuit • Controller short circuit 	

4 Error Code List

4.1 Error Code List

Alarm Code	Alarm Details	Actuation Condition	Ref. Page
E10	Output device error	Protective function of the power device actuated	P.49
E11	Overcurrent protection	Detection of instantaneous overcurrent in the current control section	P.50
E15	Insufficient voltage	Main circuit voltage drop to below DC 190 V	P.51
E16	Overvoltage	Main circuit voltage exceeding DC 400 V	P.52
E21	Motor wiring disconnection	Detection of motor wiring disconnection	P.53
E23	Current sensor error	Detection of an error of the current detection section	P.54
E24	Open phase in power supply	Detection of an open phase in the input power supply	P.55
E25	Voltage sensor error	Detection of an error in the main circuit voltage detection section	P.56
E26	Motor control error	Detection of a motor control fault	P.57
E29	Motor start error	Failure of the unit to start up normally	P.58
E30	Pressure sensor system error	An abnormal sensor value	P.59
E32	Motor lock error	Failure of the motor to rotate when started	P.60
E40	Motor thermistor disconnected/short circuited	Detection of a motor thermistor disconnection	P.61
E41	Abnormal temperature rise of motor	The motor temperature reaching 85°C for 30 seconds	P.62
E42	Radiator fin thermistor disconnection	Detection of a radiator fin thermistor disconnection	P.63
E43	Radiator fin abnormal temperature rise	The fin temperature exceeding 110°C for 1 second	P. 64, 65
E46	PCB thermistor disconnection/short circuit	Abnormal condition of the thermistor on a PCB	P.66
E47	PCB abnormal temperature rise	The PCB temperature exceeding the stipulated value for 1 second	P.67
E64	Dry operation error	The pressure failing to increase although the motor rotation speed has risen	P.68
E66	Temperature error due to pressure holding rotation speed drop	Establishment of E41 (Abnormal motor temperature rise) while L67 (Holding pressure speed drop) is in effect	P.69
E90	Internal error	Inability to initialize the software normally	P.70
E91	CPU out of control	The software load becoming excessive	P.71
E94	EEPROM data error	An abnormal parameter value	P.72
E95	Software consistency error	Detection of a mismatch between the software and hardware	P.73
E96	Internal communication error	Discontinuation of internal communication for the stipulated time	P.74

4 Troubleshooting

Alarm Code	Alarm Details	Actuation Condition	Ref. Page
L44	Abnormal temperature warning of motor	The motor temperature exceeding the stipulated value of 83°C for 10 seconds or longer	P.75
L45	Abnormal temperature warning of radiator fin	The radiator fin temperature exceeding the stipulated value of 108°C for 10 seconds or longer	P.76
L48	Abnormal temperature warning of PCB	The PCB temperature exceeding the stipulated value of 68°C for 10 seconds or longer	P.77
L49	Overload warning of motor electronic thermal	Triggering of overload detection	P.78
L50	Power supply voltage drop warning	The main circuit DC voltage value remaining under 254 V for 2 seconds or longer	P.79
L53	Controller cooling fan speed drop warning	The cooling fan speed decreasing to 80% of the normal speed or lower for 10 seconds or longer	P.80
L63	Pressure switch actuation	Actuation of the pressure switch	P.81
L67	Holding pressure rotation speed drop warning	Persistence of the overpressure status for 2 seconds at a holding pressure rotation speed of 300 min ⁻¹ or less	P.82
L70	Reverse rotation warning	The possibility of reverse rotation due to excessive load	P.83

5 Troubleshooting Flowchart

Control panel display 	Output device error
--	----------------------------

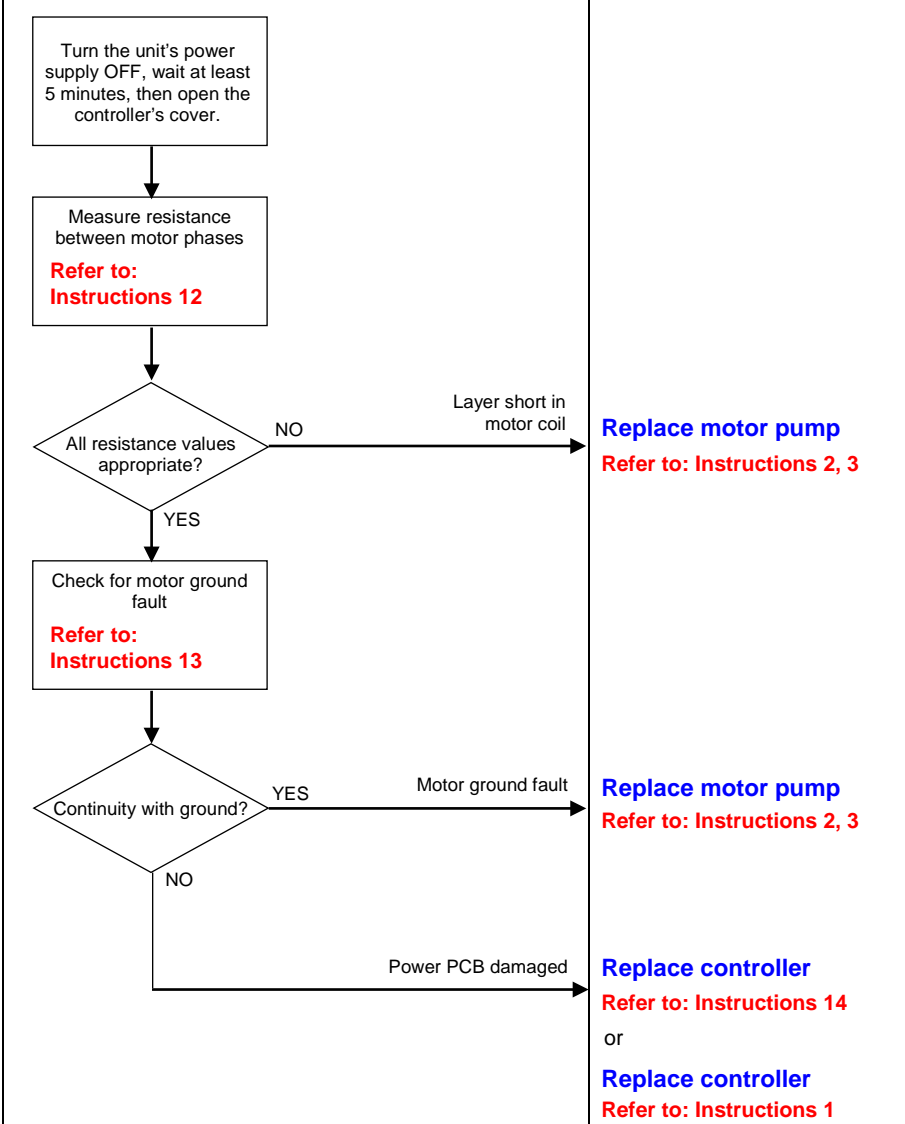
1 Applicable model	5 Troubleshooting	
EHU1404-40-* EHU2504-40-* EHU2507-40-* EHU3007-40-*	Diagnosis	Countermeasures
2 Error detection method	 <pre> graph TD A[Turn the unit's power supply OFF, wait at least 5 minutes, then open the controller's cover.] --> B[Measure resistance between motor phases Refer to: Instructions 12] B --> C{All resistance values appropriate?} C -- NO --> D[Layer short in motor coil] C -- YES --> E[Check for motor ground fault Refer to: Instructions 13] E --> F{Continuity with ground?} F -- YES --> G[Motor ground fault] F -- NO --> H[Power PCB damaged] D --> I[Replace motor pump Refer to: Instructions 2, 3] G --> I H --> J[Replace controller Refer to: Instructions 14] H --> K[or Replace controller Refer to: Instructions 1] </pre>	
Detection by the protective function at the IPM (intelligent power device)		
3 Error confirmation condition		
Error output from the IPM (intelligent power device)		
4 Probable causes	<ul style="list-style-type: none"> • Overcurrent due to motor control fault <ul style="list-style-type: none"> (1) Abnormal instantaneous overload (2) Motor wire short circuit during operation • Overheating of controller due to insufficient cooling • Controller failure (low voltage of control power supply) 	

4 Troubleshooting

Control panel display 	Overcurrent protection
--	-------------------------------

1 Applicable model	5 Troubleshooting	
EHU1404-40-* EHU2504-40-* EHU2507-40-* EHU3007-40-*	Diagnosis	Countermeasures
2 Error detection method		
By the motor current detection section		
3 Error confirmation condition		
When the overcurrent threshold value set with the software is exceeded		
4 Probable causes	<ul style="list-style-type: none"> • Overcurrent due to motor control fault (abnormal instantaneous overload) • Poor adjustment of settings for rotation speed/relief pressure at pressure changes • Occurrence of overcurrent due to load reaction caused by excessive load capacity 	

Control panel display		Insufficient voltage
-----------------------	---	-----------------------------

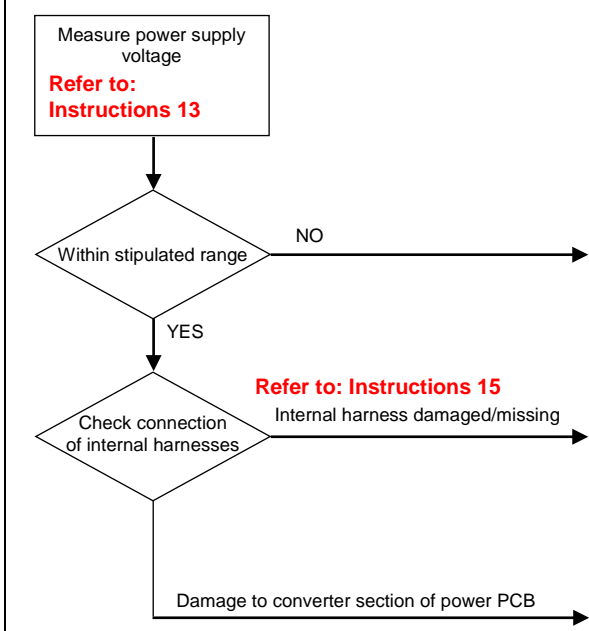
1 Applicable model	5 Troubleshooting	
EHU1404-40-* EHU2504-40-* EHU2507-40-* EHU3007-40-*	Diagnosis	Countermeasures
2 Error detection method		
Detection of the main circuit voltage		<p>Check power supply voltage if it is within rated voltage range AC 200 V ±10% 50/60 Hz AC 220 V ±10% 60 Hz</p> <p>Check internal harnesses Refer to: Instructions 15</p> <p>Replace power PCB Refer to: Instructions 14 or Replace controller Refer to: Instructions 1</p>
3 Error confirmation condition		
When the main circuit voltage falls below the stipulated voltage for 20 milliseconds or longer during operation Stipulated voltage: DC 190 V		
4 Probable causes		
<ul style="list-style-type: none"> • Drop in power supply voltage • Failure of the controller 		

4 Troubleshooting

Control panel display 	Overvoltage
--	--------------------

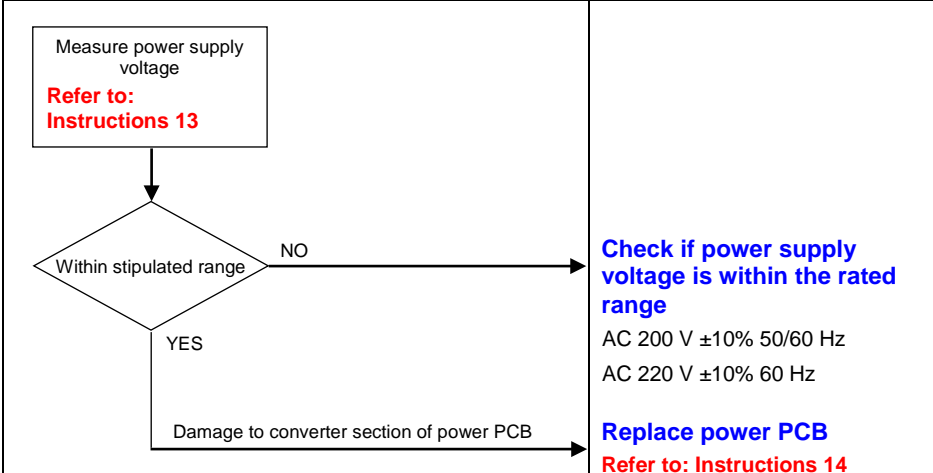
1 Applicable model	5 Troubleshooting	
EHU1404-40-* EHU2504-40-* EHU2507-40-* EHU3007-40-*	Diagnosis	Countermeasures
2 Error detection method	 <pre> graph TD A[Measure power supply voltage Refer to: Instructions 13] --> B{Within stipulated range} B -- YES --> C[Damage to converter section of power PCB] C --> D[Replace power PCB Refer to: Instructions 14] B -- NO --> E[Check if power supply voltage is within the rated range AC 200 V ±10% 50/60 Hz AC 220 V ±10% 60 Hz] </pre>	
Detection of the main circuit voltage		
3 Error confirmation condition		
When the main circuit voltage exceeds the stipulated voltage for 20 milliseconds or longer continuously during operation Stipulated voltage: DC 400 V		
4 Probable causes	Rise in power supply voltage	

Control panel display 	Motor wiring disconnection
--	-----------------------------------

1 Applicable model	5 Troubleshooting	
EHU1404-40-* EHU2504-40-* EHU2507-40-* EHU3007-40-*	Diagnosis	Countermeasures
2 Error detection method	<pre> graph TD Start[Turn the unit's power supply OFF, wait at least 5 minutes, then open the controller's cover.] --> D1{Any motor wire has come out?} D1 -- YES --> C1[Reconnect motor wires] D1 -- NO --> D2{Contact failure?} D2 -- YES --> C2[Reconnect motor wires] D2 -- NO --> B1[Measure motor wire resistance] B1 --> Note1[Refer to: Instructions 12] Note1 --> D3{Resistance detected?} D3 -- NO --> C3[Motor wire disconnection] C3 --> C4[Replace motor pump] C3 --> Note2[Refer to: Instructions 2, 3] D3 -- YES --> C5[Power PCB IPM damaged] C5 --> C6[Replace power PCB] C5 --> Note3[Refer to: Instructions 14] </pre>	
By the motor current detection circuit		
3 Error confirmation condition		
When one phase of the motor wiring is not live		
4 Probable causes	<ul style="list-style-type: none"> • Motor wire contact failure • Motor wire disconnection • Power PCB damaged 	

4 Troubleshooting

Control panel display 	Current sensor error
--	-----------------------------

<p>1 Applicable model</p> <p>EHU1404-40-* EHU2504-40-* EHU2507-40-* EHU3007-40-*</p> <p>2 Error detection method</p> <p>By the motor current detection circuit</p> <p>3 Error confirmation condition</p> <p>When there is an error in the motor current detection section and detection is not possible</p> <p>4 Probable causes</p> <ul style="list-style-type: none"> • Power PCB damaged 	<p style="text-align: center;">5 Troubleshooting</p> <table border="1" style="width: 100%; border-collapse: collapse;"> <thead> <tr> <th style="width: 50%; text-align: center;">Diagnosis</th> <th style="width: 50%; text-align: center;">Countermeasures</th> </tr> </thead> <tbody> <tr> <td style="text-align: center; vertical-align: middle;"> <div style="border: 1px solid black; padding: 5px; display: inline-block;"> Motor current detection section is damaged </div> → </td> <td style="vertical-align: middle; text-align: center;"> <p style="color: blue; font-weight: bold;">Replace power PCB</p> </td> </tr> </tbody> </table>	Diagnosis	Countermeasures	<div style="border: 1px solid black; padding: 5px; display: inline-block;"> Motor current detection section is damaged </div> →	<p style="color: blue; font-weight: bold;">Replace power PCB</p>
Diagnosis	Countermeasures				
<div style="border: 1px solid black; padding: 5px; display: inline-block;"> Motor current detection section is damaged </div> →	<p style="color: blue; font-weight: bold;">Replace power PCB</p>				

Control panel display		Open phase in power supply
-----------------------	---	-----------------------------------

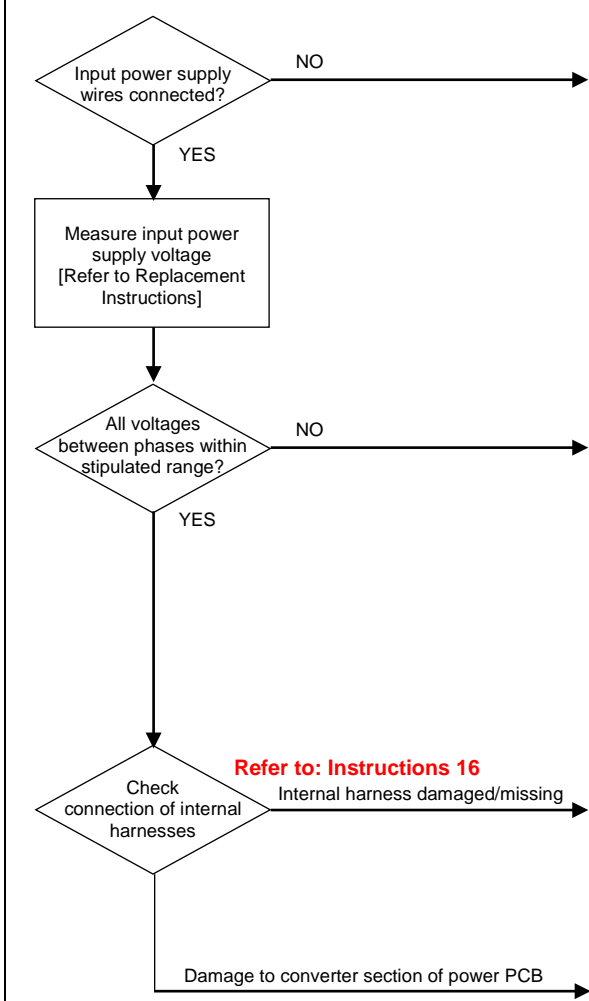
1 Applicable model	5 Troubleshooting	
EHU1404-40-* EHU2504-40-* EHU2507-40-* EHU3007-40-*	Diagnosis	Countermeasures
2 Error detection method		
By the open phase detection circuit		
3 Error confirmation condition		
When, after detection of a single open phase, an open phase is detected again 21 milliseconds later		
4 Probable causes	<ul style="list-style-type: none"> • Power supply wiring error • Open phase in the primary side power supply • Internal wiring disconnection in controller • Power PCB disconnection 	

4 Troubleshooting

Control panel display 	Voltage sensor error
--	-----------------------------

<p>1 Applicable model</p> <p>EHU1404-40-* EHU2504-40-* EHU2507-40-* EHU3007-40-*</p> <p>2 Error detection method</p> <p>By the voltage detection section</p> <p>3 Error confirmation condition</p> <p>When there is an error in the voltage detection section and voltage detection is not possible</p> <p>4 Probable causes</p> <ul style="list-style-type: none"> • Power PCB damaged 	<p style="text-align: center;">5 Troubleshooting</p> <table border="1" style="width: 100%;"> <thead> <tr> <th style="width: 50%;">Diagnosis</th> <th style="width: 50%;">Countermeasures</th> </tr> </thead> <tbody> <tr> <td style="text-align: center; vertical-align: middle;"> <div style="border: 1px solid black; padding: 5px; display: inline-block;">Voltage detection section is damaged</div> → </td> <td style="vertical-align: middle;"> <p>Replace power PCB Refer to: Instructions 14</p> <p>or</p> <p>Replace controller Refer to: Instructions 1</p> </td> </tr> </tbody> </table>	Diagnosis	Countermeasures	<div style="border: 1px solid black; padding: 5px; display: inline-block;">Voltage detection section is damaged</div> →	<p>Replace power PCB Refer to: Instructions 14</p> <p>or</p> <p>Replace controller Refer to: Instructions 1</p>
Diagnosis	Countermeasures				
<div style="border: 1px solid black; padding: 5px; display: inline-block;">Voltage detection section is damaged</div> →	<p>Replace power PCB Refer to: Instructions 14</p> <p>or</p> <p>Replace controller Refer to: Instructions 1</p>				

Control panel display		Motor control error
-----------------------	---	----------------------------

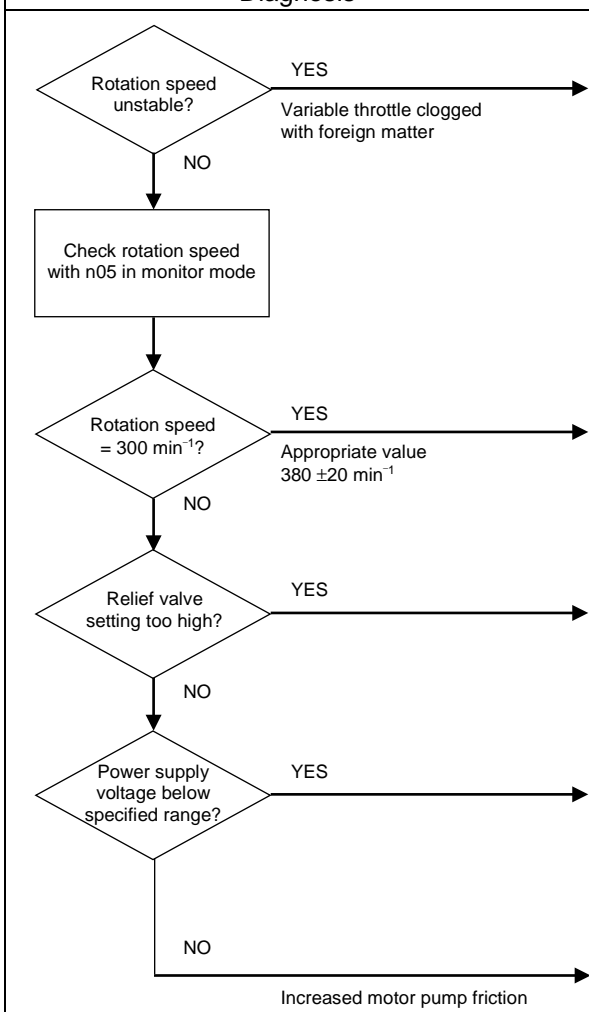
1 Applicable model	5 Troubleshooting	
EHU1404-40-* EHU2504-40-* EHU2507-40-* EHU3007-40-*	Diagnosis	Countermeasures
2 Error detection method		
By the current detection section		
3 Error confirmation condition		
Current has increased due to overload, and has diverged from the command current		
4 Probable causes	<ul style="list-style-type: none"> • Throttle clogged with foreign matter • Drop in minimum rotation speed • Inappropriate adjustment of relief valve • Power supply voltage drop • Current increase due to increase in motor pump friction 	

4 Troubleshooting

Control panel display		Motor start error
-----------------------	---	--------------------------

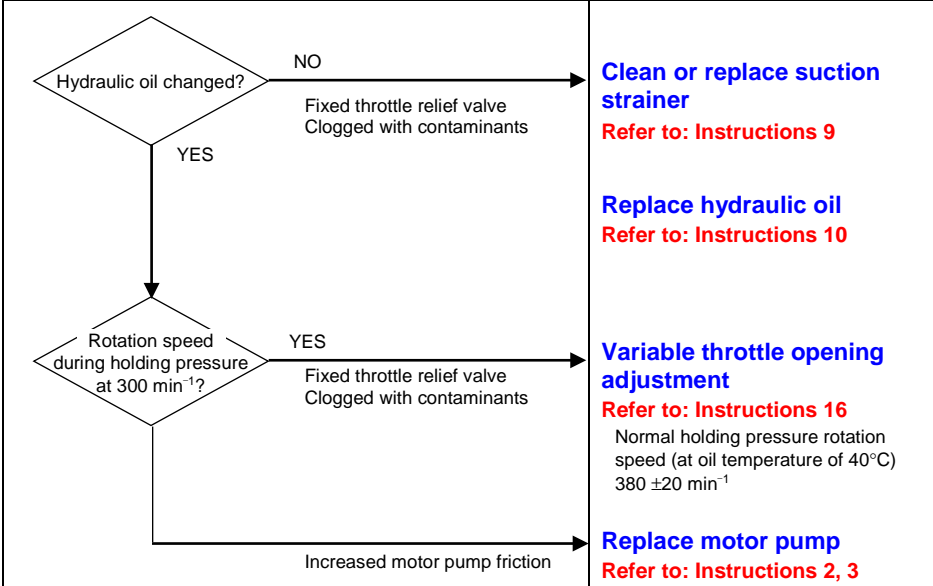
1 Applicable model	5 Troubleshooting	
EHU1404-40-* EHU2504-40-* EHU2507-40-* EHU3007-40-*	Diagnosis	Countermeasures
2 Error detection method		
By the current detection section		
3 Error confirmation condition		
When the motor does not start after the fifth retry, and subsequently rotates during the lock detection operation, resulting in judgment of the not-locked status		
4 Probable causes		
<ul style="list-style-type: none"> • Pump clogged with contaminants • Excessive load 		

Control panel display		Pressure sensor system error
-----------------------	---	-------------------------------------

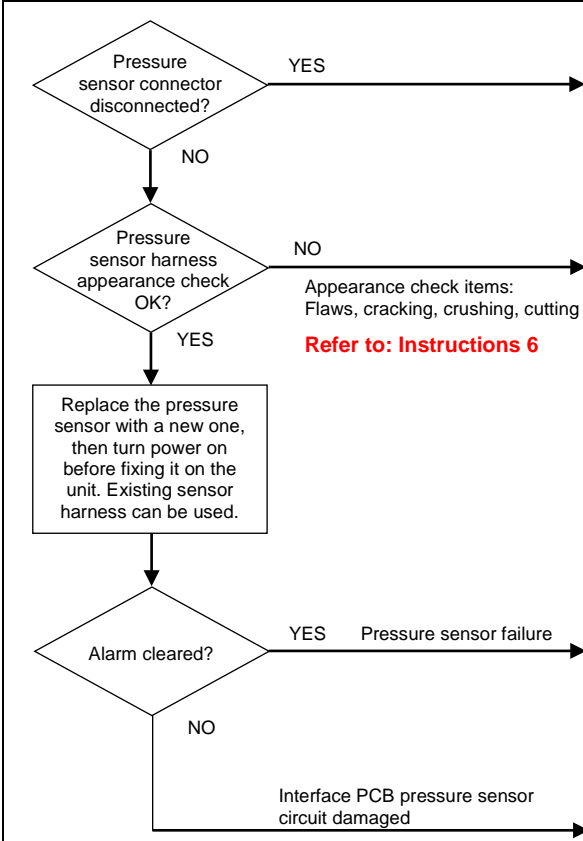
1 Applicable model	5 Troubleshooting	
EHU1404-40-* EHU2504-40-* EHU2507-40-* EHU3007-40-*	Diagnosis	Countermeasures
2 Error detection method	 <pre> graph TD A{Pressure sensor connector disconnected?} -- YES --> B[Connect pressure sensor connector] A -- NO --> C{Pressure sensor harness appearance check OK?} C -- NO --> D[Replace pressure sensor harness] C -- YES --> E[Replace the pressure sensor with a new one, then turn power on before fixing it on the unit. Existing sensor harness can be used.] E --> F{Alarm cleared?} F -- YES --> G[Replace pressure sensor] F -- NO --> H[Interface PCB pressure sensor circuit damaged] </pre> <p style="color: red;">Refer to: Instructions 5</p> <p style="color: red;">Refer to: Instructions 6</p> <p style="color: red;">Refer to: Instructions 4</p> <p style="color: red;">Refer to: Instructions 14 or 1</p>	
Detected by the pressure sensor		
3 Error confirmation condition		
<ul style="list-style-type: none"> • When disconnection or short circuit of the pressure sensor is detected • When the value detected by the pressure sensor is out of the range for 0.4 seconds or longer 		
4 Probable causes	<ul style="list-style-type: none"> • Connector unconnected/connection faulty • Pressure sensor harness disconnection • Pressure sensor failure • Pressure sensor input circuit damaged 	

4 Troubleshooting

Control panel display		Motor lock error
-----------------------	---	-------------------------

<p>1 Applicable model</p> <p>EHU1404-40-* EHU2504-40-* EHU2507-40-* EHU3007-40-*</p> <p>2 Error detection method</p> <p>By the current detection section</p> <p>3 Error confirmation condition</p> <p>When the motor did not start after the fifth retry, and subsequently did not rotate during the lock detection operation, resulting in judgment of the locked status</p> <p>4 Probable causes</p> <ul style="list-style-type: none"> • Pump shaft lock 	<p style="text-align: center;">5 Troubleshooting</p> <table border="1" style="width: 100%;"> <thead> <tr> <th style="width: 50%;">Diagnosis</th> <th style="width: 50%;">Countermeasures</th> </tr> </thead> <tbody> <tr> <td style="text-align: center; vertical-align: middle;"> <div style="border: 1px solid black; padding: 5px; display: inline-block;">Motor pump shaft is fixed</div> → </td> <td style="vertical-align: middle;"> <p>Replace motor pump</p> <p>Refer to: Instructions 2, 3</p> </td> </tr> </tbody> </table>	Diagnosis	Countermeasures	<div style="border: 1px solid black; padding: 5px; display: inline-block;">Motor pump shaft is fixed</div> →	<p>Replace motor pump</p> <p>Refer to: Instructions 2, 3</p>
Diagnosis	Countermeasures				
<div style="border: 1px solid black; padding: 5px; display: inline-block;">Motor pump shaft is fixed</div> →	<p>Replace motor pump</p> <p>Refer to: Instructions 2, 3</p>				

Control panel display	E40	Motor thermistor disconnected/short circuited
-----------------------	---	--

1 Applicable model
EHU1404-40-* EHU2504-40-* EHU2507-40-* EHU3007-40-*
2 Error detection method
By the voltage value detected by the thermistor input circuit
3 Error confirmation condition
When a disconnection or short circuit of the motor thermistor is detected 3 mV or lower or 4.69 V or higher
4 Probable causes
<ul style="list-style-type: none"> • Connector not connected • Connector contact faulty • Thermistor failure • Thermistor input circuit damaged

5 Troubleshooting																																														
<p style="text-align: center;">Diagnosis</p> <div style="text-align: center;"> <div style="border: 1px solid black; padding: 5px; margin-bottom: 10px;">Check motor thermistor connection Refer to: Instructions 15</div> <div style="display: flex; justify-content: center; align-items: center; margin-bottom: 10px;"> <div style="border: 1px solid black; padding: 5px; margin-right: 10px;">Motor thermistor connector disconnected?</div> <div style="margin-right: 10px;">YES</div> <div style="font-size: 2em;">→</div> </div> <div style="display: flex; justify-content: center; align-items: center; margin-bottom: 10px;"> <div style="border: 1px solid black; padding: 5px; margin-right: 10px;">Check resistance value of motor thermistor * See the table below.</div> <div style="margin-right: 10px;">NO</div> <div style="font-size: 2em;">↓</div> </div> <div style="display: flex; justify-content: center; align-items: center; margin-bottom: 10px;"> <div style="border: 1px solid black; padding: 5px; margin-right: 10px;">Motor thermistor resistance normal?</div> <div style="margin-right: 10px;">NO</div> <div style="font-size: 2em;">→</div> </div> <div style="display: flex; justify-content: center; align-items: center;"> <div style="border: 1px solid black; padding: 5px; margin-right: 10px;">Interface PCB thermistor circuit damaged</div> <div style="font-size: 2em;">→</div> </div> </div>	<p style="text-align: center;">Countermeasures</p> <div style="text-align: center; margin-top: 20px;"> <p style="color: blue; font-weight: bold;">Connect motor thermistor connector</p> <p style="color: red; font-weight: bold;">Refer to: Instructions 15</p> </div> <div style="text-align: center; margin-top: 20px;"> <p style="color: blue; font-weight: bold;">Replace motor pump</p> <p style="color: red; font-weight: bold;">Refer to: Instructions 2, 3</p> </div> <div style="text-align: center; margin-top: 20px;"> <p style="color: blue; font-weight: bold;">Replace interface PCB</p> <p style="color: red; font-weight: bold;">Refer to: Instructions 14</p> <p>or</p> <p style="color: blue; font-weight: bold;">Replace controller</p> <p style="color: red; font-weight: bold;">Refer to: Instructions 1</p> </div>																																													
<table border="1" style="width: 100%; border-collapse: collapse; margin: 0 auto;"> <thead> <tr> <th style="padding: 2px;">Temperature [°C]</th> <th style="padding: 2px;">Resistance [kΩ]</th> <th style="padding: 2px;"></th> <th style="padding: 2px;">Temperature [°C]</th> <th style="padding: 2px;">Resistance [kΩ]</th> </tr> </thead> <tbody> <tr><td style="padding: 2px;">0</td><td style="padding: 2px;">65.9</td><td style="padding: 2px;"></td><td style="padding: 2px;">80</td><td style="padding: 2px;">2.5</td></tr> <tr><td style="padding: 2px;">10</td><td style="padding: 2px;">40.0</td><td style="padding: 2px;"></td><td style="padding: 2px;">90</td><td style="padding: 2px;">1.82</td></tr> <tr><td style="padding: 2px;">20</td><td style="padding: 2px;">25.0</td><td style="padding: 2px;"></td><td style="padding: 2px;">100</td><td style="padding: 2px;">1.35</td></tr> <tr><td style="padding: 2px;">30</td><td style="padding: 2px;">16.1</td><td style="padding: 2px;"></td><td style="padding: 2px;">110</td><td style="padding: 2px;">1.01</td></tr> <tr><td style="padding: 2px;">40</td><td style="padding: 2px;">10.6</td><td style="padding: 2px;"></td><td style="padding: 2px;">120</td><td style="padding: 2px;">0.77</td></tr> <tr><td style="padding: 2px;">50</td><td style="padding: 2px;">7.18</td><td style="padding: 2px;"></td><td style="padding: 2px;">130</td><td style="padding: 2px;">0.59</td></tr> <tr><td style="padding: 2px;">60</td><td style="padding: 2px;">4.95</td><td style="padding: 2px;"></td><td style="padding: 2px;">140</td><td style="padding: 2px;">0.46</td></tr> <tr><td style="padding: 2px;">70</td><td style="padding: 2px;">3.49</td><td style="padding: 2px;"></td><td style="padding: 2px;">150</td><td style="padding: 2px;">0.37</td></tr> </tbody> </table>		Temperature [°C]	Resistance [kΩ]		Temperature [°C]	Resistance [kΩ]	0	65.9		80	2.5	10	40.0		90	1.82	20	25.0		100	1.35	30	16.1		110	1.01	40	10.6		120	0.77	50	7.18		130	0.59	60	4.95		140	0.46	70	3.49		150	0.37
Temperature [°C]	Resistance [kΩ]		Temperature [°C]	Resistance [kΩ]																																										
0	65.9		80	2.5																																										
10	40.0		90	1.82																																										
20	25.0		100	1.35																																										
30	16.1		110	1.01																																										
40	10.6		120	0.77																																										
50	7.18		130	0.59																																										
60	4.95		140	0.46																																										
70	3.49		150	0.37																																										

4 Troubleshooting

Control panel display 	<h2>Abnormal temperature rise of motor</h2>	The threshold value can be determined from the setting for H53 (Motor abnormal temperature threshold). Set value [0]: Alarm detection temperature: 85°C Set value [other than 0]: Alarm detection temperature: Parameter value
--	---	---

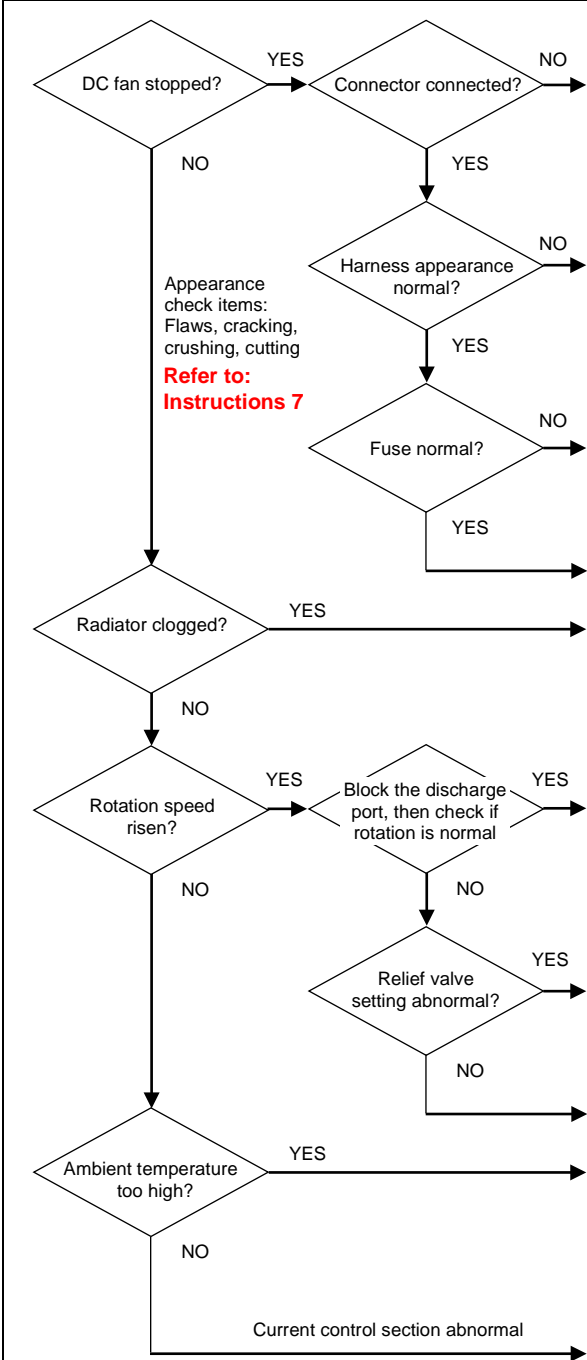
<h3>1 Applicable model</h3> <p>EHU1404-40-* EHU2504-40-* EHU2507-40-* EHU3007-40-*</p>	<h3>5 Troubleshooting</h3>	
<h3>2 Error detection method</h3> <p>Detected by the motor thermistor</p>	<h4>Diagnosis</h4> 	<h4>Countermeasures</h4> <p>Connect connectors Refer to: Instructions 6</p> <p>Replace DC fan harness Refer to: Instructions 7</p> <p>Replace fuse Refer to: Instructions 11</p> <p>Replace DC fan Refer to: Instructions 8</p> <p>Clean or replace radiator Refer to: Instructions 8</p> <p>Oil leakage from main machine circuit increased</p> <p>Adjust relief valve Refer to: Instructions 16</p> <p>Replace motor pump Refer to: Instructions 2, 3</p> <p>Improve ambient temperature condition</p> <p>Replace power PCB Refer to: Instructions 14</p>
<h3>3 Error confirmation condition</h3> <p>When the detected temperature exceeds the set value for 30 seconds or longer ⇒ Alarm output if operation continues</p>		
<h3>4 Probable causes</h3> <ul style="list-style-type: none"> • DC fan stopped • Radiator clogged • Rotation speed rise • High ambient temperature 		

Control panel display 	Radiator fin thermistor disconnection
--	--

<p>1 Applicable model</p> <p>EHU1404-40-* EHU2504-40-* EHU2507-40-* EHU3007-40-*</p>	5 Troubleshooting	
<p>2 Error detection method</p> <p>Detection of abnormality based on the voltage value detected by the fin thermistor</p>	<div style="border: 1px solid black; padding: 5px; display: inline-block;">Radiator fin thermistor circuit failure</div> →	<p style="text-align: center;">Diagnosis</p>
<p>3 Error confirmation condition</p> <p>In case circuit damage is detected, the condition is 3 mV or lower or 4.92 V or higher</p>	<p style="text-align: center;">Countermeasures</p> <p style="color: blue; text-align: center;">Replace power PCB Refer to: Instructions 14</p> <p style="text-align: center;">or</p> <p style="color: blue; text-align: center;">Replace controller Refer to: Instructions 1</p>	<p style="text-align: center;">4 Probable causes</p> <ul style="list-style-type: none"> • Thermistor failure • Thermistor input circuit damaged

4 Troubleshooting

Control panel display 	Radiator fin abnormal temperature rise
--	---

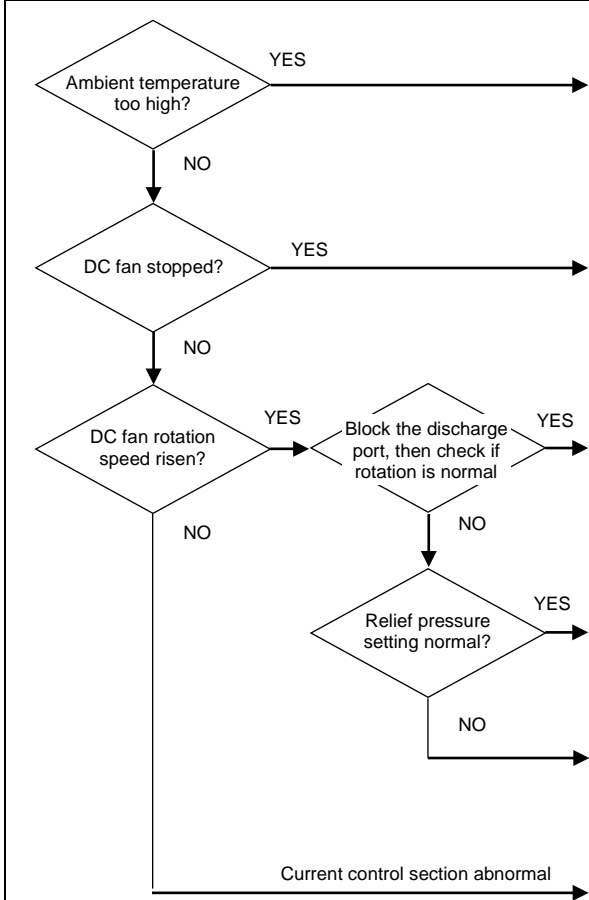
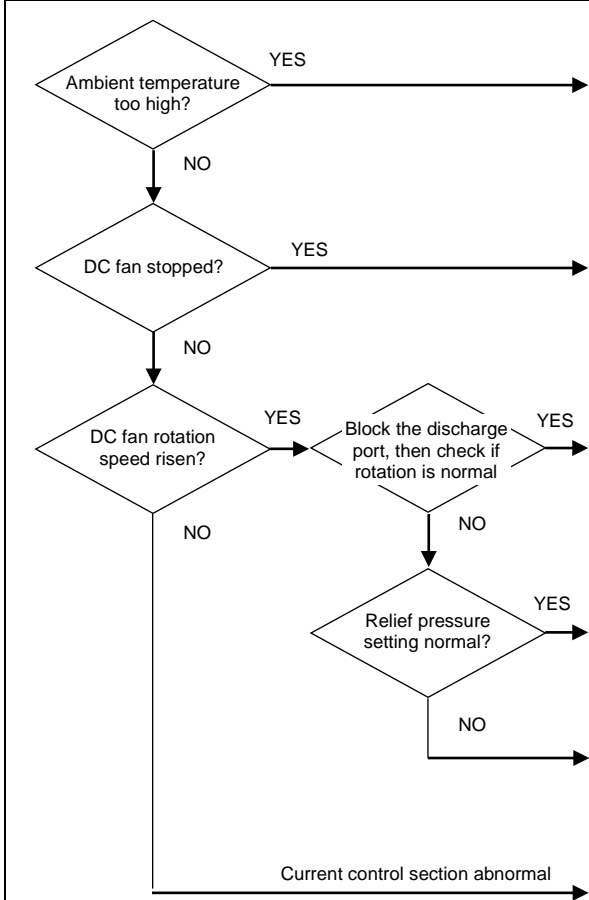
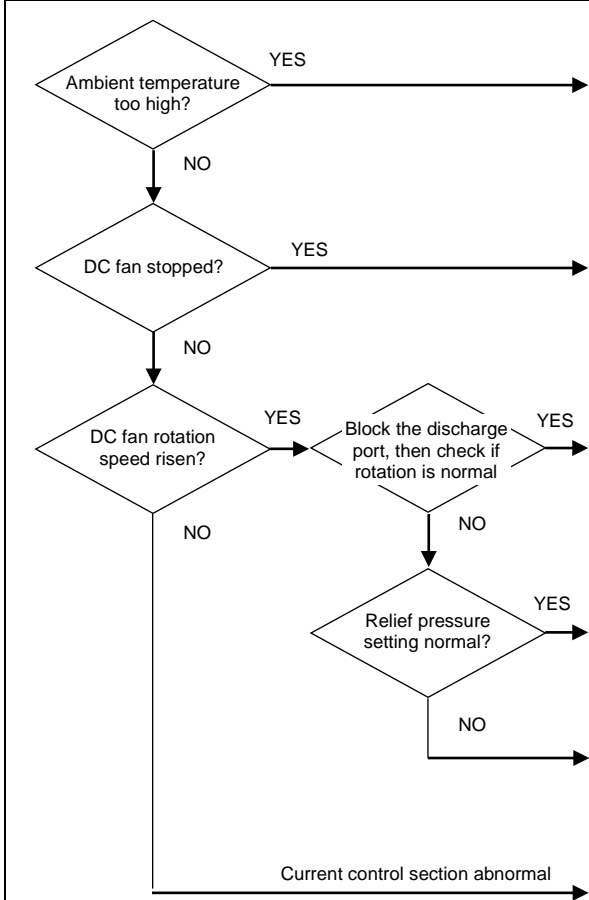
<p>1 Applicable model</p> <p>EHU1404-40-* EHU2504-40-* EHU2507-40-* EHU3007-40-*</p> <p>2 Error detection method</p> <p>Detection of abnormality based on the voltage value detected by the fin thermistor input circuit</p> <p>3 Error confirmation condition</p> <p>When the detected temperature exceeded 110°C for 1 second or longer</p> <p>4 Probable causes</p> <ul style="list-style-type: none"> • Motor rotation speed rise • High ambient temperature 	<p>5 Troubleshooting</p> <table border="1" style="width: 100%;"> <thead> <tr> <th style="width: 70%;">Diagnosis</th> <th style="width: 30%;">Countermeasures</th> </tr> </thead> <tbody> <tr> <td style="vertical-align: top;">  <pre> graph TD A{Ambient temperature too high?} -- YES --> B[Improve ambient temperature condition] A -- NO --> C{DC fan stopped?} C -- YES --> D[Abnormal temperature rise at a radiator fin Refer to fan output errors] C -- NO --> E{DC fan rotation speed risen?} E -- YES --> F[Block the discharge port, then check if rotation is normal] F -- YES --> G[Oil leakage on a main machine increased] F -- NO --> H{Relief pressure setting normal?} H -- YES --> I[Replace motor pump Refer to: Instructions 2, 3] H -- NO --> J[Adjust relief valve pressure Refer to: Instructions 16] E -- NO --> K[Current control section abnormal] K --> L[Replace power PCB Refer to: Instructions 14 or Replace controller Refer to: Instructions 1] </pre> </td> <td style="vertical-align: top;"> <p>Improve ambient temperature condition</p> <p>Abnormal temperature rise at a radiator fin Refer to fan output errors</p> <p>Oil leakage on a main machine increased</p> <p>Normal value: Pressure setting +0.5 to 1.0 MPa</p> <p>Replace motor pump Refer to: Instructions 2, 3</p> <p>Adjust relief valve pressure Refer to: Instructions 16</p> <p>Replace power PCB Refer to: Instructions 14 or Replace controller Refer to: Instructions 1</p> </td> </tr> </tbody> </table>	Diagnosis	Countermeasures	 <pre> graph TD A{Ambient temperature too high?} -- YES --> B[Improve ambient temperature condition] A -- NO --> C{DC fan stopped?} C -- YES --> D[Abnormal temperature rise at a radiator fin Refer to fan output errors] C -- NO --> E{DC fan rotation speed risen?} E -- YES --> F[Block the discharge port, then check if rotation is normal] F -- YES --> G[Oil leakage on a main machine increased] F -- NO --> H{Relief pressure setting normal?} H -- YES --> I[Replace motor pump Refer to: Instructions 2, 3] H -- NO --> J[Adjust relief valve pressure Refer to: Instructions 16] E -- NO --> K[Current control section abnormal] K --> L[Replace power PCB Refer to: Instructions 14 or Replace controller Refer to: Instructions 1] </pre>	<p>Improve ambient temperature condition</p> <p>Abnormal temperature rise at a radiator fin Refer to fan output errors</p> <p>Oil leakage on a main machine increased</p> <p>Normal value: Pressure setting +0.5 to 1.0 MPa</p> <p>Replace motor pump Refer to: Instructions 2, 3</p> <p>Adjust relief valve pressure Refer to: Instructions 16</p> <p>Replace power PCB Refer to: Instructions 14 or Replace controller Refer to: Instructions 1</p>
Diagnosis	Countermeasures				
 <pre> graph TD A{Ambient temperature too high?} -- YES --> B[Improve ambient temperature condition] A -- NO --> C{DC fan stopped?} C -- YES --> D[Abnormal temperature rise at a radiator fin Refer to fan output errors] C -- NO --> E{DC fan rotation speed risen?} E -- YES --> F[Block the discharge port, then check if rotation is normal] F -- YES --> G[Oil leakage on a main machine increased] F -- NO --> H{Relief pressure setting normal?} H -- YES --> I[Replace motor pump Refer to: Instructions 2, 3] H -- NO --> J[Adjust relief valve pressure Refer to: Instructions 16] E -- NO --> K[Current control section abnormal] K --> L[Replace power PCB Refer to: Instructions 14 or Replace controller Refer to: Instructions 1] </pre>	<p>Improve ambient temperature condition</p> <p>Abnormal temperature rise at a radiator fin Refer to fan output errors</p> <p>Oil leakage on a main machine increased</p> <p>Normal value: Pressure setting +0.5 to 1.0 MPa</p> <p>Replace motor pump Refer to: Instructions 2, 3</p> <p>Adjust relief valve pressure Refer to: Instructions 16</p> <p>Replace power PCB Refer to: Instructions 14 or Replace controller Refer to: Instructions 1</p>				

Control panel display		Radiator fin abnormal temperature rise
-----------------------	---	---

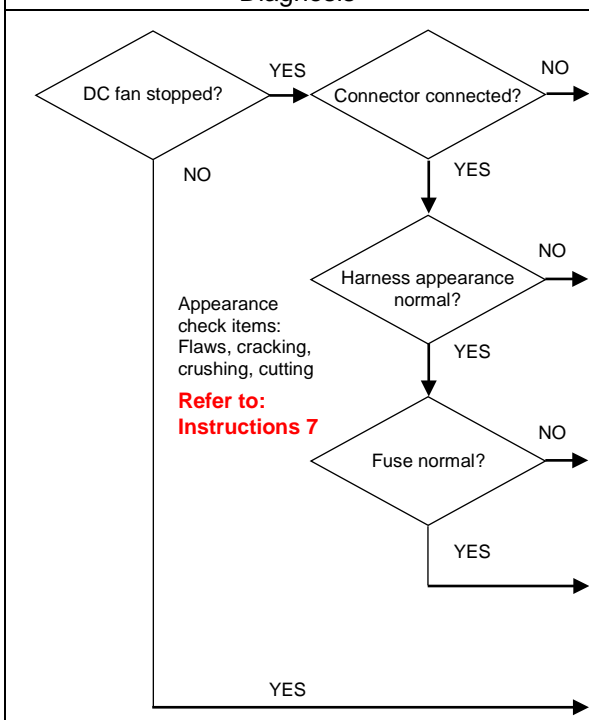
1 Applicable model	5 Troubleshooting	
EHU1404-40-* EHU2504-40-* EHU2507-40-* EHU3007-40-*	Diagnosis	Countermeasures
2 Error detection method	 <pre> graph TD A{DC fan stopped?} -- YES --> B{Connector connected?} A -- NO --> E[Clean or replace radiator Refer to: Instructions 8] B -- NO --> C[Connect connectors Refer to: Instructions 6] B -- YES --> D{Harness appearance normal?} D -- NO --> F[Replace DC fan harness Refer to: Instructions 7] D -- YES --> G{Fuse normal?} G -- NO --> H[Replace fuse Refer to: Instructions 11] G -- YES --> I[Replace DC fan Refer to: Instructions 8] </pre> <p>Appearance check items: Flaws, cracking, crushing, cutting Refer to: Instructions 7</p>	
Detection of abnormality based on the voltage value detected by the fin thermistor input circuit		
3 Error confirmation condition		
When the detected temperature exceeded 110°C for 1 second or longer		
4 Probable causes	<ul style="list-style-type: none"> • Motor rotation speed rise • High ambient temperature 	

4 Troubleshooting

Control panel display 	PCB thermistor disconnection/short circuit
--	---

<p>1 Applicable model</p> <p>EHU1404-40-* EHU2504-40-* EHU2507-40-* EHU3007-40-*</p> <p>2 Error detection method</p> <p>Detection of abnormality based on the voltage value detected by the PCB thermistor</p> <p>3 Error confirmation condition</p> <p>In case circuit damage is detected, the condition is 3 mV or lower or 4.92 V or higher</p> <p>4 Probable causes</p> <ul style="list-style-type: none"> • Thermistor failure • Thermistor input circuit damaged 	<p style="text-align: center;">5 Troubleshooting</p> <table border="1" style="width: 100%;"> <thead> <tr> <th style="width: 50%;">Diagnosis</th> <th style="width: 50%;">Countermeasures</th> </tr> </thead> <tbody> <tr> <td style="text-align: center; vertical-align: middle;"> <div style="border: 1px solid black; padding: 5px; display: inline-block;">PCB thermistor circuit failure</div> → </td> <td style="vertical-align: middle;"> <p>Replace interface PCB Refer to: Instructions 14</p> </td> </tr> </tbody> </table>	Diagnosis	Countermeasures	<div style="border: 1px solid black; padding: 5px; display: inline-block;">PCB thermistor circuit failure</div> →	<p>Replace interface PCB Refer to: Instructions 14</p>
Diagnosis	Countermeasures				
<div style="border: 1px solid black; padding: 5px; display: inline-block;">PCB thermistor circuit failure</div> →	<p>Replace interface PCB Refer to: Instructions 14</p>				

Control panel display		PCB abnormal temperature rise
-----------------------	---	--------------------------------------

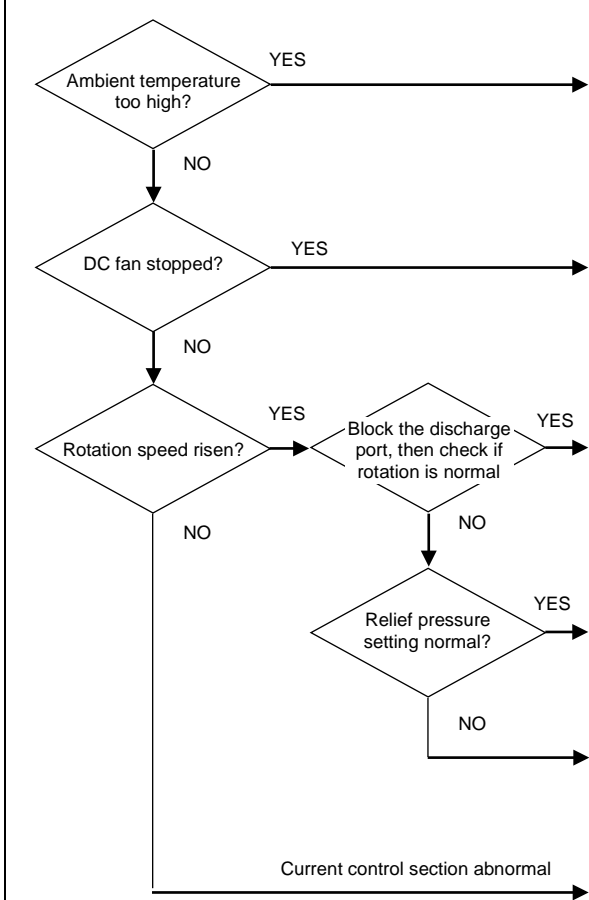
1 Applicable model	5 Troubleshooting	
EHU1404-40-* EHU2504-40-* EHU2507-40-* EHU3007-40-*	Diagnosis	Countermeasures
2 Error detection method	 <pre> graph TD A{Ambient temperature too high?} -- YES --> B[Improve ambient temperature condition] A -- NO --> C{DC fan stopped?} C -- YES --> D[Abnormal temperature rise at a radiator fin Refer to fan output errors] C -- NO --> E{Rotation speed risen?} E -- YES --> F{Block the discharge port, then check if rotation is normal} F -- YES --> G[Oil leakage on a main machine increased] F -- NO --> H{Relief pressure setting normal?} H -- YES --> I[Replace motor pump Refer to: Instructions 2, 3] H -- NO --> J[Adjust relief valve pressure Refer to: Instructions 16] E -- NO --> K[Current control section abnormal] K --> L[Replace power PCB Refer to: Instructions 14 or Replace controller Refer to: Instructions 1] </pre>	
Detection of abnormality based on the voltage value detected by the PCB thermistor		
3 Error confirmation condition		
When the detected temperature exceeded 70°C for 1 second or longer		
4 Probable causes	<ul style="list-style-type: none"> • DC fan stopped • Radiator clogged • Rotation speed rise • High ambient temperature 	

4 Troubleshooting

Control panel display 	Dry operation error
--	----------------------------

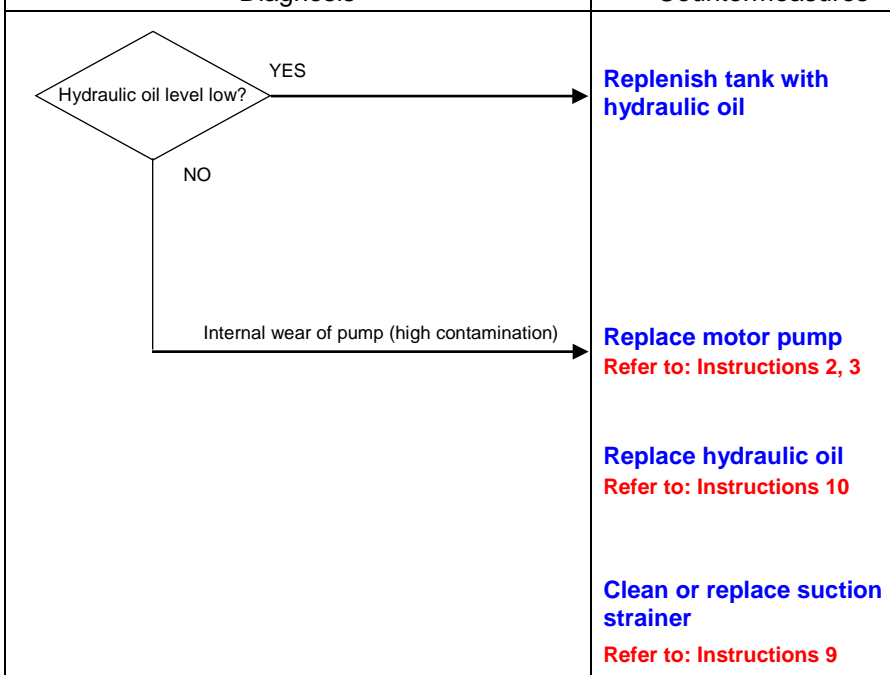
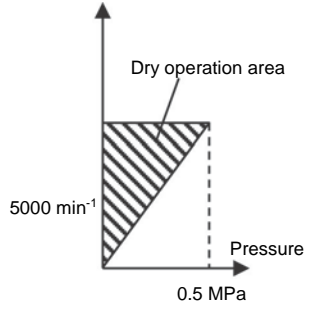
1 Applicable model	5 Troubleshooting	
EHU1404-40-* EHU2504-40-* EHU2507-40-* EHU3007-40-*	Diagnosis	Countermeasures
2 Error detection method		
Judge based on control pressure and control rotation speed		
3 Error confirmation condition		
When continuously operated for the stipulated time in the dry operation area		
Rotation speed 		
4 Probable causes		
<ul style="list-style-type: none"> • Hydraulic oil level low? • Motor wires connected incorrectly (reverse rotation) • Increased internal leakage of pump 		

Control panel display 	<h2>Temperature error due to pressure holding rotation speed drop</h2>
--	--

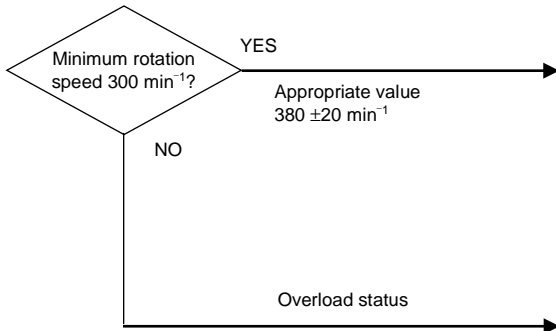
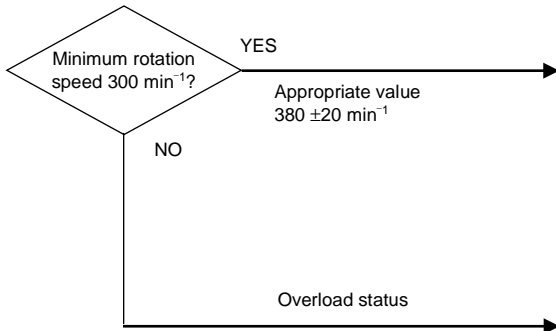
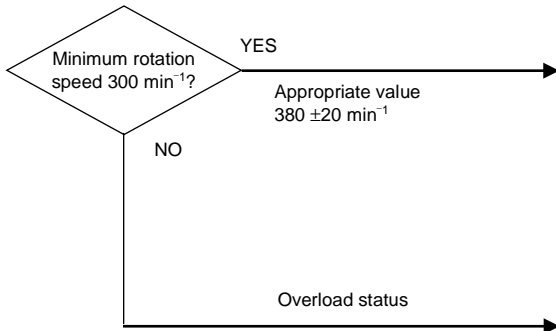
<h3>1 Applicable model</h3> <p>EHU1404-40-* EHU2504-40-* EHU2507-40-* EHU3007-40-*</p>	<h3>5 Troubleshooting</h3> <table border="1" style="width: 100%;"> <thead> <tr> <th style="width: 70%;">Diagnosis</th> <th>Countermeasures</th> </tr> </thead> <tbody> <tr> <td style="text-align: center;">  <pre> graph TD A{Minimum rotation speed 300 min⁻¹?} -- YES --> B[Appropriate value 380 ±20 min⁻¹] A -- NO --> C[Overload status] </pre> </td> <td style="vertical-align: top;"> <p>Variable throttle opening adjustment Refer to: Instructions 16</p> <p>Replace motor pump Refer to: Instructions 2, 3</p> </td> </tr> </tbody> </table>		Diagnosis	Countermeasures	 <pre> graph TD A{Minimum rotation speed 300 min⁻¹?} -- YES --> B[Appropriate value 380 ±20 min⁻¹] A -- NO --> C[Overload status] </pre>	<p>Variable throttle opening adjustment Refer to: Instructions 16</p> <p>Replace motor pump Refer to: Instructions 2, 3</p>
Diagnosis	Countermeasures					
 <pre> graph TD A{Minimum rotation speed 300 min⁻¹?} -- YES --> B[Appropriate value 380 ±20 min⁻¹] A -- NO --> C[Overload status] </pre>	<p>Variable throttle opening adjustment Refer to: Instructions 16</p> <p>Replace motor pump Refer to: Instructions 2, 3</p>					
<h3>2 Error detection method</h3> <p>Judge based on motor rotation speed and motor temperature</p>						
<h3>3 Error confirmation condition</h3> <p>(1) E41 Motor abnormal temperature rise has been detected while the L67 (Holding pressure speed drop) alert is in effect. (2) When L67 is detected while P46 Maintenance implementation is enabled.</p>						
<h3>4 Probable causes</h3> <ul style="list-style-type: none"> • Variable throttle for adjusting minimum rotation speed clogged with foreign matter • Minimum rotation speed adjustment faulty • Current increase due to overload 						

4 Troubleshooting

Control panel display 	Internal error
--	-----------------------

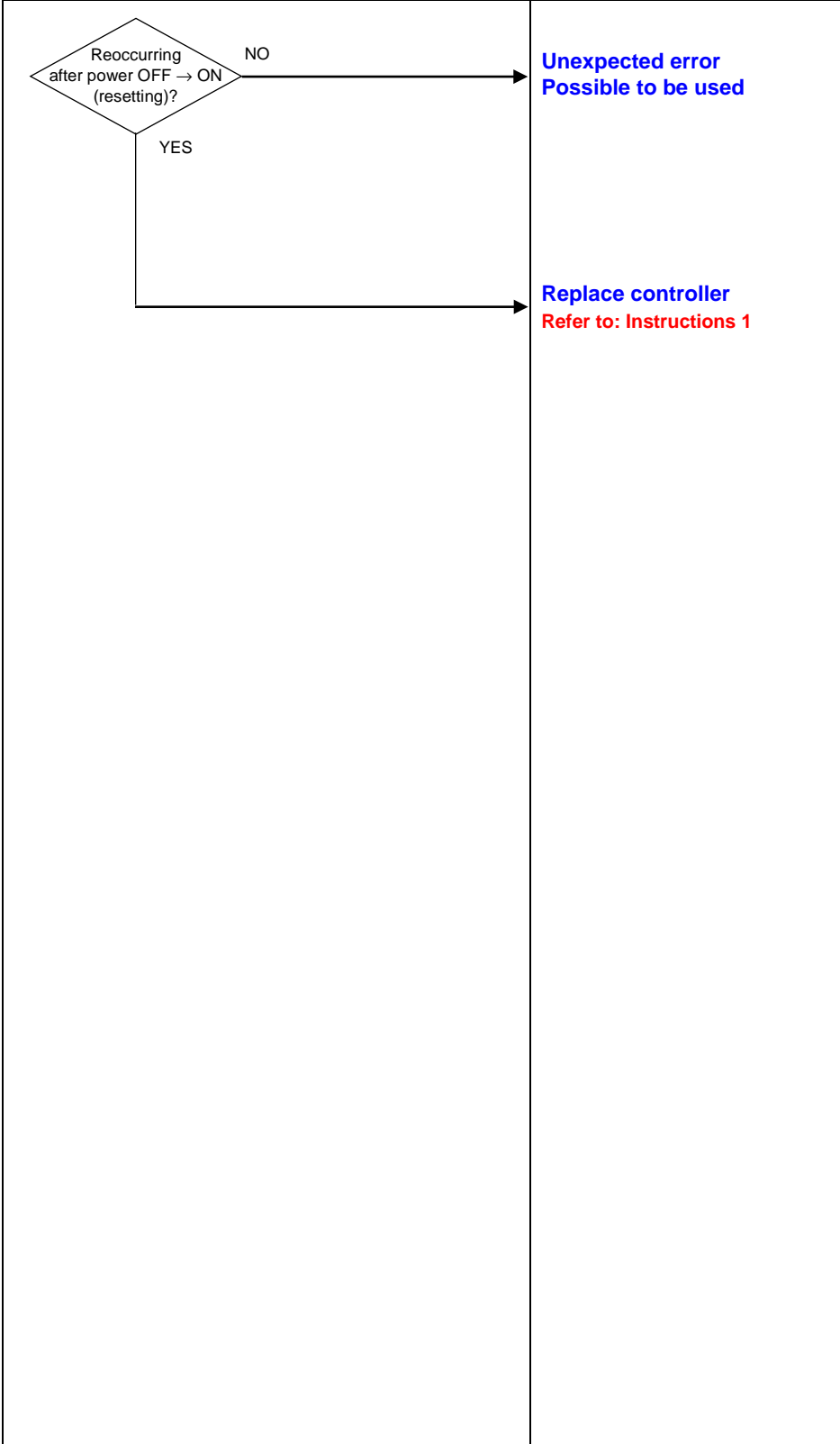
1 Applicable model	5 Troubleshooting	
EHU1404-40-* EHU2504-40-* EHU2507-40-* EHU3007-40-*	Diagnosis	Countermeasures
2 Error detection method	 <pre> graph TD A{Reoccurring after power OFF -> ON (resetting)?} -- NO --> B[Unexpected error Possible to be used] A -- YES --> C[Replace controller Refer to: Instructions 1] </pre>	
By the software program		
3 Error confirmation condition		
Normal initialization is not possible.		
4 Probable causes	<ul style="list-style-type: none"> • Communication error between PCBs • Application software failure • Initialization process overtime 	

Control panel display		CPU out of control
-----------------------	---	---------------------------

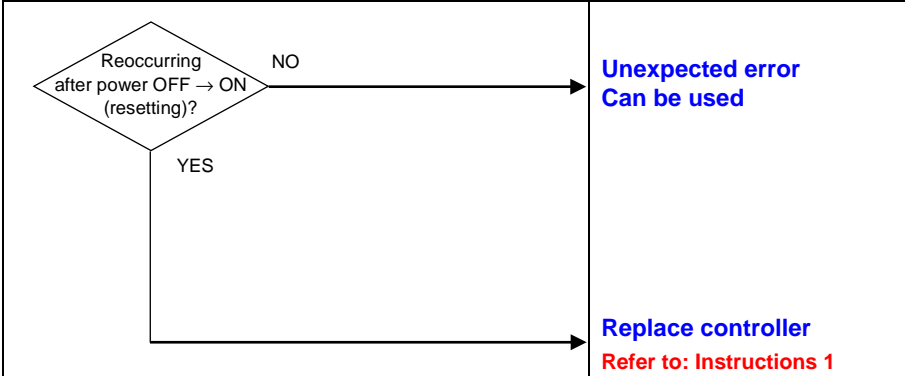
1 Applicable model	5 Troubleshooting	
EHU1404-40-* EHU2504-40-* EHU2507-40-* EHU3007-40-*	Diagnosis	Countermeasures
2 Error detection method	 <pre> graph TD A{Reoccurring after power OFF -> ON (resetting)?} -- NO --> B[Unexpected error Can be used] A -- YES --> C[Replace controller Refer to: Instructions 1] </pre>	
By the software program		
3 Error confirmation condition		
Application failure		
4 Probable causes		
<ul style="list-style-type: none"> • CPU out of control • Program execution time error 		

4 Troubleshooting

Control panel display 	EEPROM data error
--	--------------------------

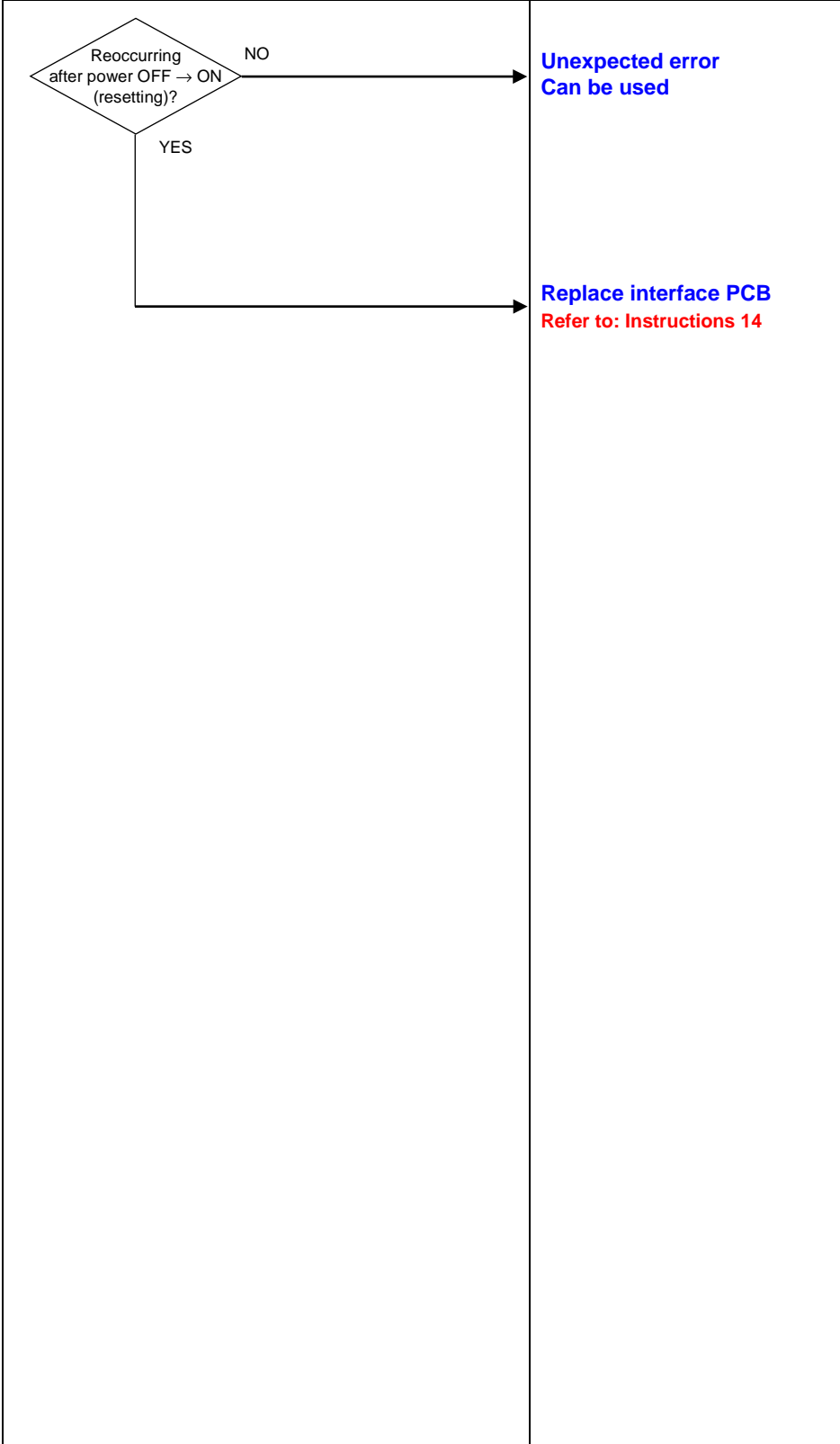
1 Applicable model	5 Troubleshooting	
EHU1404-40-* EHU2504-40-* EHU2507-40-* EHU3007-40-*	Diagnosis	Countermeasures
2 Error detection method	 <pre> graph TD A{Reoccurring after power OFF -> ON (resetting)?} -- NO --> B[Unexpected error Can be used] A -- YES --> C[Replace interface PCB Refer to: Instructions 14] </pre>	
By the software program		
3 Error confirmation condition		
Parameter values out of range		
4 Probable causes		
<ul style="list-style-type: none"> EEPROM data error 		

Control panel display 	Software consistency error
--	-----------------------------------

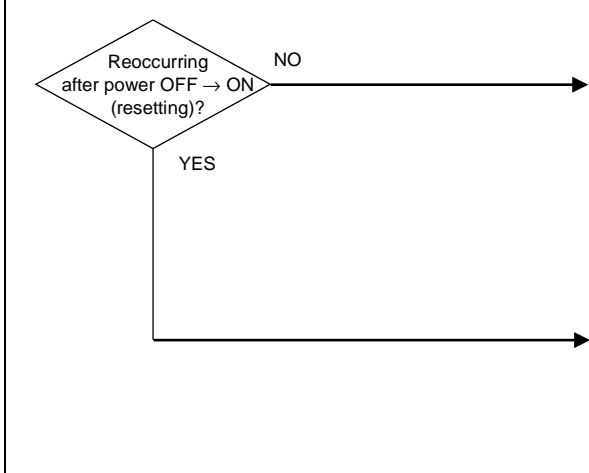
1 Applicable model	5 Troubleshooting	
EHU1404-40-* EHU2504-40-* EHU2507-40-* EHU3007-40-*	Diagnosis	Countermeasures
2 Error detection method	 <pre> graph TD A{Reoccurring after power OFF -> ON (resetting)?} -- NO --> B[Unexpected error Can be used] A -- YES --> C[Replace interface PCB Refer to: Instructions 14 or Replace controller Refer to: Instructions 1] </pre>	
Detected by the software		
3 Error confirmation condition		
(1) When the parameter value (unit ID) of the interface PCB and the analog identification value of the power PCB are different (2) When the interface PCB and power PCB have different communication formats		
4 Probable causes		
<ul style="list-style-type: none"> • EEPROM fault • Power PCB identification section failure 		

4 Troubleshooting

Control panel display 	Internal communication error
--	-------------------------------------

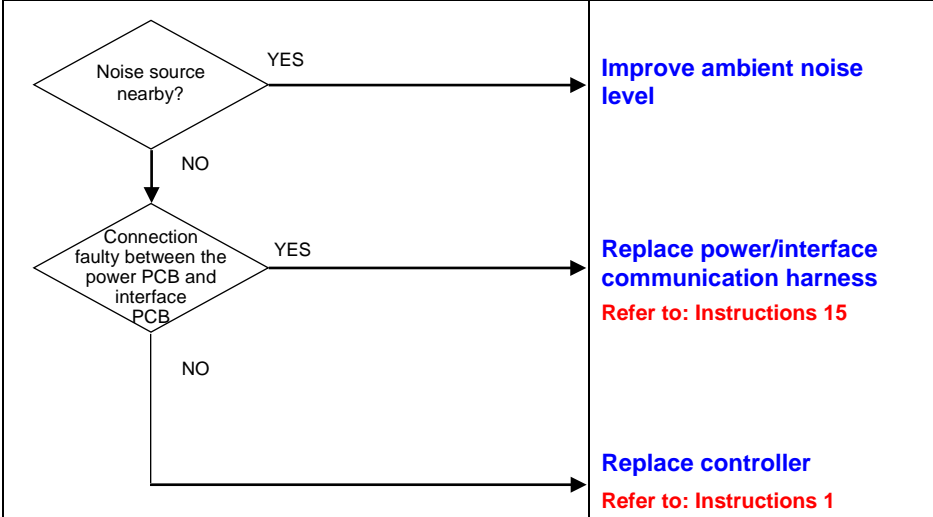
1 Applicable model	5 Troubleshooting	
EHU1404-40-* EHU2504-40-* EHU2507-40-* EHU3007-40-*	Diagnosis	Countermeasures
2 Error detection method	 <pre> graph TD A{Noise source nearby?} -- YES --> B[Improve ambient noise level] A -- NO --> C{Connection faulty between the power PCB and interface PCB} C -- YES --> D[Replace power/interface communication harness Refer to: Instructions 15] C -- NO --> E[Replace controller Refer to: Instructions 1] </pre>	
Detected by the software		
3 Error confirmation condition		
Internal communication error between interface PCB and power PCB		
4 Probable causes		
<ul style="list-style-type: none"> • Communication cable faulty • Noise 		

Control panel display	<div style="border: 1px solid black; padding: 5px; display: inline-block; font-family: monospace; font-size: 2em; margin: 0 10px;">L44</div> <h2 style="margin: 0;">Abnormal temperature warning of motor</h2>
-----------------------	--

<h3>1 Applicable model</h3> <p>EHU1404-40-* EHU2504-40-* EHU2507-40-* EHU3007-40-*</p>	<h3>5 Troubleshooting</h3> <table border="1" style="width: 100%;"> <thead> <tr> <th style="width: 70%;">Diagnosis</th> <th style="width: 30%;">Countermeasures</th> </tr> </thead> <tbody> <tr> <td style="vertical-align: top;"> <pre> graph TD A{DC fan stopped?} -- YES --> B{Connector connected?} A -- NO --> C{Radiator clogged?} B -- YES --> D{Harness appearance normal?} B -- NO --> C1[Connect connectors Refer to: Instructions 6] D -- YES --> E{Fuse normal?} D -- NO --> C2[Replace DC fan harness Refer to: Instructions 7] E -- YES --> F[Replace DC fan Refer to: Instructions 8] E -- NO --> C3[Replace fuse Refer to: Instructions 11] C -- YES --> C4[Clean or replace radiator Refer to: Instructions 8] C -- NO --> G{Rotation speed risen?} G -- YES --> H{Block the discharge port, then check if rotation is normal?} G -- NO --> I{Relief valve setting abnormal?} H -- YES --> C5[Oil leakage on a main machine increased] H -- NO --> I I -- YES --> C6[Adjust relief valve Refer to: Instructions 16] I -- NO --> C7[Replace motor pump Refer to: Instructions 2, 3] J{Ambient temperature too high?} -- YES --> C8[Improve ambient temperature condition] J -- NO --> K[Current control section abnormal] K --> C9[Replace power PCB Refer to: Instructions 14] </pre> </td> <td style="vertical-align: top;"> <p>Connect connectors Refer to: Instructions 6</p> <p>Replace DC fan harness Refer to: Instructions 7</p> <p>Replace fuse Refer to: Instructions 11</p> <p>Replace DC fan Refer to: Instructions 8</p> <p>Clean or replace radiator Refer to: Instructions 8</p> <p>Oil leakage on a main machine increased</p> <p>Adjust relief valve Refer to: Instructions 16</p> <p>Replace motor pump Refer to: Instructions 2, 3</p> <p>Improve ambient temperature condition</p> <p>Replace power PCB Refer to: Instructions 14</p> </td> </tr> </tbody> </table>	Diagnosis	Countermeasures	<pre> graph TD A{DC fan stopped?} -- YES --> B{Connector connected?} A -- NO --> C{Radiator clogged?} B -- YES --> D{Harness appearance normal?} B -- NO --> C1[Connect connectors Refer to: Instructions 6] D -- YES --> E{Fuse normal?} D -- NO --> C2[Replace DC fan harness Refer to: Instructions 7] E -- YES --> F[Replace DC fan Refer to: Instructions 8] E -- NO --> C3[Replace fuse Refer to: Instructions 11] C -- YES --> C4[Clean or replace radiator Refer to: Instructions 8] C -- NO --> G{Rotation speed risen?} G -- YES --> H{Block the discharge port, then check if rotation is normal?} G -- NO --> I{Relief valve setting abnormal?} H -- YES --> C5[Oil leakage on a main machine increased] H -- NO --> I I -- YES --> C6[Adjust relief valve Refer to: Instructions 16] I -- NO --> C7[Replace motor pump Refer to: Instructions 2, 3] J{Ambient temperature too high?} -- YES --> C8[Improve ambient temperature condition] J -- NO --> K[Current control section abnormal] K --> C9[Replace power PCB Refer to: Instructions 14] </pre>	<p>Connect connectors Refer to: Instructions 6</p> <p>Replace DC fan harness Refer to: Instructions 7</p> <p>Replace fuse Refer to: Instructions 11</p> <p>Replace DC fan Refer to: Instructions 8</p> <p>Clean or replace radiator Refer to: Instructions 8</p> <p>Oil leakage on a main machine increased</p> <p>Adjust relief valve Refer to: Instructions 16</p> <p>Replace motor pump Refer to: Instructions 2, 3</p> <p>Improve ambient temperature condition</p> <p>Replace power PCB Refer to: Instructions 14</p>
Diagnosis	Countermeasures				
<pre> graph TD A{DC fan stopped?} -- YES --> B{Connector connected?} A -- NO --> C{Radiator clogged?} B -- YES --> D{Harness appearance normal?} B -- NO --> C1[Connect connectors Refer to: Instructions 6] D -- YES --> E{Fuse normal?} D -- NO --> C2[Replace DC fan harness Refer to: Instructions 7] E -- YES --> F[Replace DC fan Refer to: Instructions 8] E -- NO --> C3[Replace fuse Refer to: Instructions 11] C -- YES --> C4[Clean or replace radiator Refer to: Instructions 8] C -- NO --> G{Rotation speed risen?} G -- YES --> H{Block the discharge port, then check if rotation is normal?} G -- NO --> I{Relief valve setting abnormal?} H -- YES --> C5[Oil leakage on a main machine increased] H -- NO --> I I -- YES --> C6[Adjust relief valve Refer to: Instructions 16] I -- NO --> C7[Replace motor pump Refer to: Instructions 2, 3] J{Ambient temperature too high?} -- YES --> C8[Improve ambient temperature condition] J -- NO --> K[Current control section abnormal] K --> C9[Replace power PCB Refer to: Instructions 14] </pre>	<p>Connect connectors Refer to: Instructions 6</p> <p>Replace DC fan harness Refer to: Instructions 7</p> <p>Replace fuse Refer to: Instructions 11</p> <p>Replace DC fan Refer to: Instructions 8</p> <p>Clean or replace radiator Refer to: Instructions 8</p> <p>Oil leakage on a main machine increased</p> <p>Adjust relief valve Refer to: Instructions 16</p> <p>Replace motor pump Refer to: Instructions 2, 3</p> <p>Improve ambient temperature condition</p> <p>Replace power PCB Refer to: Instructions 14</p>				
<h3>2 Error detection method</h3> <p>Detected based on the value of the thermistor's connection AD port</p>					
<h3>3 Error confirmation condition</h3> <p>When the detected temperature exceeded 83°C for 10 seconds or longer</p>					
<h3>4 Probable causes</h3> <ul style="list-style-type: none"> • DC fan stopped • Radiator clogged • High ambient temperature 					

4 Troubleshooting

Control panel display 	Abnormal temperature warning of radiator fin
--	---

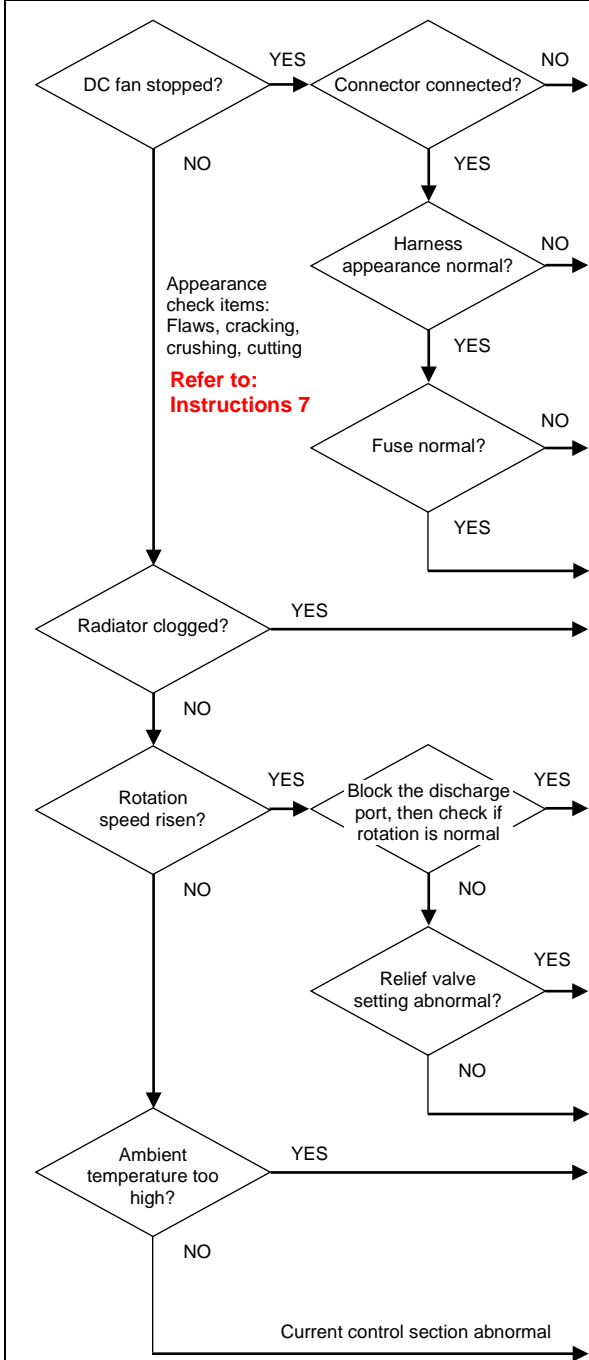
1 Applicable model	5 Troubleshooting	
EHU1404-40-* EHU2504-40-* EHU2507-40-* EHU3007-40-*	Diagnosis 	Countermeasures Connect connectors Refer to: Instructions 6 Replace DC fan harness Refer to: Instructions 7 Replace fuse Refer to: Instructions 11 Replace DC fan Refer to: Instructions 8 Clean or replace radiator Refer to: Instructions 8 Oil leakage on a main machine increased Adjust relief valve Refer to: Instructions 16 Replace motor pump Refer to: Instructions 2, 3 Improve ambient temperature condition Replace power PCB Refer to: Instructions 14
2 Error detection method		
Detected based on the value of the thermistor's connection AD port		
3 Error confirmation condition		
When the detected temperature exceeded 73°C for 10 seconds or longer		
4 Probable causes		
<ul style="list-style-type: none"> • DC fan stopped • Radiator clogged • High ambient temperature 		

Control panel display	<div style="border: 1px solid black; padding: 5px; display: inline-block; font-family: monospace; font-size: 24px; margin: 0 auto;">L48</div>	Abnormal temperature warning of PCB
-----------------------	---	--

1 Applicable model	5 Troubleshooting	
EHU1404-40-* EHU2504-40-* EHU2507-40-* EHU3007-40-*	Diagnosis	Countermeasures
2 Error detection method	<pre> graph TD A{DC fan stopped?} -- YES --> B{Connector connected?} A -- NO --> C{Radiator clogged?} B -- YES --> D{Harness appearance normal?} B -- NO --> CM1[Connect connectors Refer to: Instructions 6] D -- YES --> E{Fuse normal?} D -- NO --> CM2[Replace DC fan harness Refer to: Instructions 7] E -- YES --> CM3[Replace DC fan Refer to: Instructions 8] E -- NO --> CM4[Replace fuse Refer to: Instructions 11] C -- YES --> CM5[Clean or replace radiator Refer to: Instructions 8] C -- NO --> F{Rotation speed risen?} F -- YES --> G{Block the discharge port, then check if rotation is normal?} F -- NO --> H{Relief valve setting abnormal?} G -- YES --> CM6[Oil leakage on a main machine increased] G -- NO --> H H -- YES --> CM7[Adjust relief valve Refer to: Instructions 16] H -- NO --> CM8[Replace motor pump Refer to: Instructions 2, 3] I{Ambient temperature too high?} -- YES --> CM9[Improve ambient temperature condition] I -- NO --> J[Current control section abnormal] J --> CM10[Replace power PCB Refer to: Instructions 14] </pre>	
3 Error confirmation condition		
When the detected temperature exceeded 68°C for 10 seconds or longer		
4 Probable causes		
<ul style="list-style-type: none"> • DC fan stopped • Radiator clogged • High ambient temperature 		

4 Troubleshooting

Control panel display 	Overload warning of motor electronic thermal
--	---

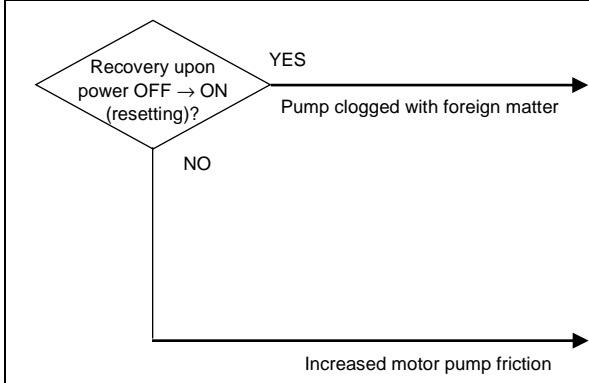
<p>1 Applicable model</p> <p>EHU1404-40-* EHU2504-40-* EHU2507-40-* EHU3007-40-*</p>	5 Troubleshooting	
<p>2 Error detection method</p> <p>Judgment of the load factor based on the detected motor current value</p>	Diagnosis	Countermeasures
<p>3 Error confirmation condition</p> <p>When the value of the motor current average load factor has exceeded the threshold (default 105%)</p>	 <pre> graph TD A{Recovery upon power OFF -> ON (resetting)?} -- YES --> B[Pump clogged with foreign matter] A -- NO --> C[Increased motor pump friction] B --> D["Clean or replace suction strainer Refer to: Instructions 9"] C --> E["Replace motor pump Refer to: Instructions 2, 3"] </pre>	
<p>4 Probable causes</p> <ul style="list-style-type: none"> • Overload caused by clogging with contamination or foreign matter • Pump failure (increased friction) 		

Control panel display 	Power supply voltage drop warning
--	--

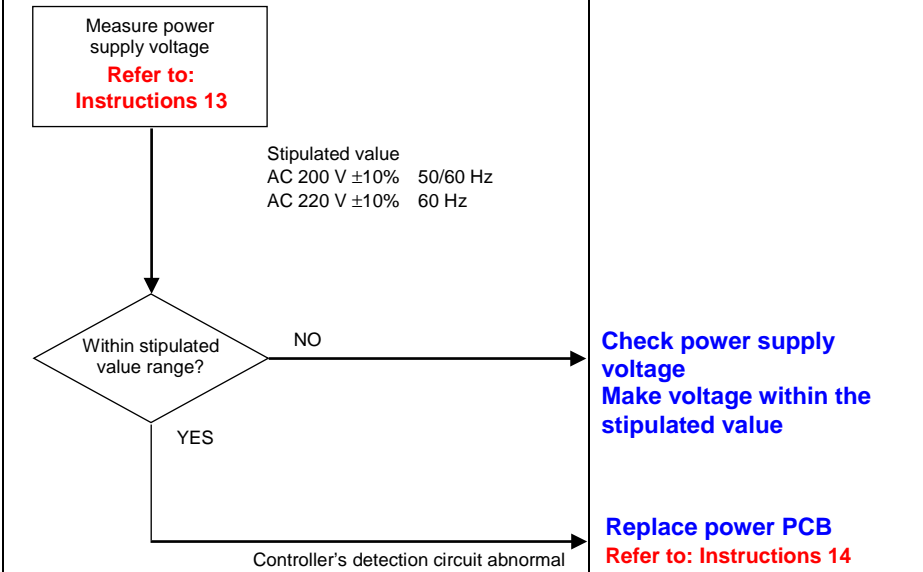
1 Applicable model	5 Troubleshooting	
EHU1404-40-* EHU2504-40-* EHU2507-40-* EHU3007-40-*	Diagnosis	Countermeasures
2 Error detection method	 <pre> graph TD A[Measure power supply voltage Refer to: Instructions 13] --> B{Within stipulated value range?} B -- NO --> C[Check power supply voltage Make voltage within the stipulated value] B -- YES --> D[Replace power PCB Refer to: Instructions 14 or Replace controller Refer to: Instructions 1] </pre>	
Detected based on the voltage level of the main circuit		
3 Error confirmation condition		
When the main circuit voltage remains under a level of around AC 180 V for 2 seconds or longer		
4 Probable causes		
Drop in power supply voltage		

4 Troubleshooting

Control panel display		Controller cooling fan speed drop warning
-----------------------	---	--

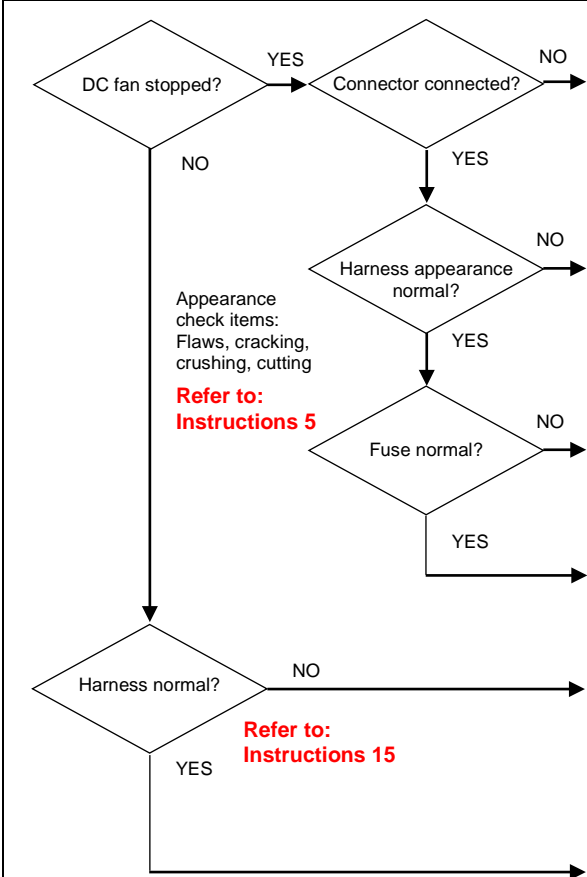
1 Applicable model	5 Troubleshooting	
EHU1404-40-* EHU2504-40-* EHU2507-40-* EHU3007-40-*	Diagnosis	Countermeasures
2 Error detection method	 <pre> graph TD A{DC fan stopped?} -- YES --> B{Connector connected?} A -- NO --> D{Harness normal?} B -- NO --> C1[Connect connectors Refer to: Instructions 6] B -- YES --> C2{Harness appearance normal?} C2 -- NO --> C2a[Replace DC fan harness Refer to: Instructions 7] C2 -- YES --> C3{Fuse normal?} C3 -- NO --> C3a[Replace fuse Refer to: Instructions 11] C3 -- YES --> C3b[Replace DC fan Refer to: Instructions 8] D -- NO --> C4[Replace DC fan harness Refer to: Instructions 5] D -- YES --> C5[Replace interface PCB Refer to: Instructions 14] </pre>	
3 Error confirmation condition		
The cooling fan speed decreasing to 80% of the normal speed or lower for 10 seconds or longer		
4 Probable causes		
<ul style="list-style-type: none"> • Fan connector connection faulty • DC fan failure • Blown fuse • DC fan harness failure • Interface PCB failure 		

Control panel display	L63	Pressure switch actuation
-----------------------	------------	----------------------------------

1 Applicable model
EHU1404-40-* EHU2504-40-* EHU2507-40-* EHU3007-40-*
2 Error detection method
Detected based on the control pressure and pressure switch judgment value
3 Error confirmation condition
When the recovery pressure has not been reached even on elapse of the delay time after actuation of the pressure switch Recovery pressure: Set pressure + 0.5 MPa
4 Probable causes
Pressure switch actuation

5 Troubleshooting																
Diagnosis	Countermeasures															
<pre> graph TD A{Nothing abnormal in operation of main machine} -- YES --> B[Pressure switch actuation notification (cleared with ENT key)] A -- NO --> C{No other main machine abnormality factors?} C -- YES --> D[Disable function] C -- NO --> E[Review pressure switch setting or extend pressure switch output delay time.] </pre>	<p style="color: blue; font-weight: bold;">Pressure switch actuation notification (cleared with ENT key)</p> <p style="color: blue; font-weight: bold;">Investigate other factors</p> <p style="color: blue; font-weight: bold;">Disable function</p> <p style="color: blue; font-weight: bold;">Review pressure switch setting or extend pressure switch output delay time.</p>															
<table border="1" style="width: 100%; border-collapse: collapse;"> <tr> <td colspan="3" style="padding: 2px;">[P03:PSWH] Pressure switch indication retention setting</td> </tr> <tr> <td style="width: 10%; padding: 2px;">Value</td> <td style="width: 40%; padding: 2px;">L63 Indication Retention</td> <td style="width: 50%; padding: 2px;">Recording in Alarm History</td> </tr> <tr> <td style="text-align: center; padding: 2px;">0</td> <td style="padding: 2px;">Not retained (No indication)</td> <td style="text-align: center; padding: 2px;">No recorded</td> </tr> <tr> <td style="text-align: center; padding: 2px;">1</td> <td style="padding: 2px;">Retained (Indication given)</td> <td style="text-align: center; padding: 2px;">No recorded</td> </tr> <tr> <td style="text-align: center; padding: 2px;">2</td> <td style="padding: 2px;">Retained (Indication given)</td> <td style="text-align: center; padding: 2px;">Recorded</td> </tr> </table>		[P03:PSWH] Pressure switch indication retention setting			Value	L63 Indication Retention	Recording in Alarm History	0	Not retained (No indication)	No recorded	1	Retained (Indication given)	No recorded	2	Retained (Indication given)	Recorded
[P03:PSWH] Pressure switch indication retention setting																
Value	L63 Indication Retention	Recording in Alarm History														
0	Not retained (No indication)	No recorded														
1	Retained (Indication given)	No recorded														
2	Retained (Indication given)	Recorded														
<div style="background-color: #ffffcc; padding: 5px; border: 1px solid black;"> <p>[Pressure switch indication retention function] This is an indication that notifies actuation of the pressure switch.</p> <p>Same contact output is used for pressure switch actuation and alarms on ECORICH, so it can be difficult to distinguish them.</p> <p>If the actuation of the pressure switch is recognized as an alarm but the unit operates normally, it is not possible to identify why the alarm was output.</p> <p>Using this function makes it clear when the pressure switch actuated and that it is not an alarm occurrence.</p> </div>																

4 Troubleshooting

Control panel display		Holding pressure rotation speed drop warning
-----------------------	--	---

1 Applicable model	5 Troubleshooting	
EHU1404-40-* EHU2504-40-* EHU2507-40-* EHU3007-40-*	Diagnosis	Countermeasures
2 Error detection method	<pre> graph TD A{Minimum rotation speed 300 min⁻¹?} -- YES --> B[Appropriate value 380 ± 20 min⁻¹] B --> C[Variable throttle opening adjustment Refer to: Instructions 16] A -- NO --> D[Relief valve failure] D --> E[Replace relief valve Refer to: Instructions 2, 3] </pre>	
Judge based on motor rotation speed and motor temperature		
3 Error confirmation condition		
Persistence of the overpressure status for 2 seconds at a holding pressure rotation speed of 300 min ⁻¹ or less		
4 Probable causes		
<ul style="list-style-type: none"> • Variable throttle for adjusting minimum rotation speed clogged with foreign matter • Minimum rotation speed adjustment faulty 		

Control panel display		Reverse rotation warning
-----------------------	---	---------------------------------

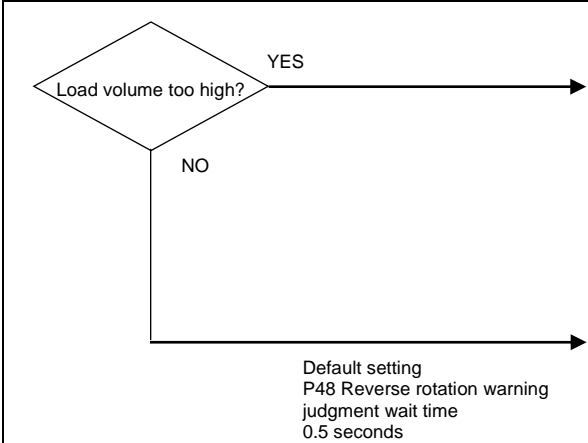
1 Applicable model	5 Troubleshooting	
EHU1404-40-* EHU2504-40-* EHU2507-40-* EHU3007-40-*	Diagnosis	Countermeasures
2 Error detection method	 <pre> graph TD A{Load volume too high?} -- YES --> B[Working normally Delay the timing of the run command] A -- NO --> C[Judgment time is short Check the parameter] </pre> <p style="text-align: center;">Default setting P48 Reverse rotation warning judgment wait time 0.5 seconds</p>	
Judge based on the rotation speed and pressure value		
3 Error confirmation condition		
When the pressure does not fall to the stipulated value or lower even after elapse of the stipulated time after the run command switches from OFF to ON		
4 Probable causes		
<ul style="list-style-type: none"> • Readjust judgment parameters • Rotating in reverse under an excessive load 		

5 Settings at Part Replacement

1 Checking the Setting Data

When the following parts are replaced, it is necessary to check the original setting data and input this same data after replacing the part.

1.1 Parts for which setting data is required to be input

Interface PCB, controller, unit

1.2 Data checking methods

(1) Checking method by the control panel

Check and record each data item by referring to (3) "Setting mode" and (5) "Internal parameter mode" in Chapter 3 "Control Panel".

(2) Checking method by model name with non-standard control numbers

If it is not possible to check the unit's settings (when the unit won't start up, for example) before starting the work, check the model name with the non-standard control number stated on the unit's name plate.

Then acquire the "List of setting values for non-standard units" from the Field Information BANK – Product Information – Hydraulic Related site, and check the initial settings for each item.

2 Setting Procedure

2.1 When replacing the interface PCB, controller, or unit

When replacing the interface PCB, controller or unit, input the data in by following the instructions below before replacement.

(1) Setting the setting items

- Check the settings of the unit before the replacement and those of the latest software, and set the recorded settings for the same item numbers.
- If it is not possible to check the settings on the unit before replacement, check the data in the "List of setting values for non-standard units" from the Field Information BANK – Product Information – Hydraulic Related site.

3 Parameter Setting List

3.1 Setting mode

Item	Code	Name	Details
P00	DI_A	Start/stop signal switching	DIN1: Sets the effective logic for the start/stop signal.
P01	SW_L	Pressure switch	Sets the actuation pressure of the pressure switch.
P02	T_SW	Pressure switch output delay time	Sets the delay time from when the pressure falls below the set value for "P01: Pressure switch" to confirmation of the pressure drop.
P03	PSWH	Hold setting for pressure switch indication	When the "L63: Pressure switch actuation" warning has occurred, the "L63" indication displayed on the operation panel can be retained.
P04	DS_P	Unit selection of pressure	Enables selection of the display unit for pressures displayed on the panel.
P05	K_RT	(Reserved for the system)	This is reserved for the system.
P06	D_RT	(Reserved for the system)	This is reserved for the system.
P07	WN_M	(Reserved for the system)	This is reserved for the system.
P08	AMIX	(Reserved for the system)	This is reserved for the system.
P09	INIF	Initialize to default setting	Initializes the parameters to their default values.
P10	L_TI	PQ integration time correction factor	Sets the integration time correction factor for PQ control.
P11	M_VR	(Reserved for the system)	This is reserved for the system.
P12	W_TM	(Reserved for the system)	This is reserved for the system.
P13	PL.0	Pressure setting	Sets the target pressure.
	QL.0	Flow volume setting	Sets the target flow rate.
P14-28		(Reserved for the system)	This is reserved for the system.
P29	C_TM	(Reserved for the system)	This is reserved for the system.
P30	DF_N	(Reserved for the system)	This is reserved for the system.
P31	P_SN	Pressure sensor rated value	Sets the rated pressure of the pressure sensor.
P32	S_TM	Surgeless start time	Sets the start-up time for a smooth start of the motor.
P33	L_IN	(Reserved for the system)	This is reserved for the system.
P34	E_TM	(Reserved for the system)	This is reserved for the system.
P35	DR_L	Dry operation judgment pressure	Sets the pressure condition for judging "E64: Dry operation error".
P36	DR_T	Dry operation judgment time	Sets the time for judging "E64: Dry operation error".
P37	SM_R	(Reserved for the system)	This is reserved for the system.
P38	P_DF	No detection zone of pressure switch	Sets the threshold value for detecting pressure recovery, after actuation of the pressure switch. This is set as a difference in the positive direction in relation to "P01: Pressure switch".
P39	DO_S	Digital output selection	Sets the content of signals output from digital outputs and alarm outputs.
P40	PL_D	(Reserved for the system)	This is reserved for the system.
P41	PCMW	(Reserved for the system)	This is reserved for the system.
P42	PCMM	(Reserved for the system)	This is reserved for the system.
P43	QCMW	(Reserved for the system)	This is reserved for the system.
P44	QCMM	(Reserved for the system)	This is reserved for the system.
P45	AC_F	Cooling fan motor rotation speed	Switches the operation speed of the cooling fan.

5 Settings at Part Replacement

Item	Code	Name	Details
P46	TVMJ	Maintenance implementation review enable/disable	Selects whether or not to issue an E66 (motor temperature rise due to pressure holding speed drop) alarm on occurrence of an L67 (pressure holding speed drop) warning while "H52: TVMR Maintenance request" is set to 1.
P47	RMOT	Alarm relay output maintenance notification enable/disable	Selects whether or not to repeat alarm relay ON/OFF on occurrence of an L67 (pressure holding speed drop) warning or an E66 (motor temperature rise due to pressure holding speed drop) alarm.
P48	T_SP	Reverse rotation warning judgment time	Sets the judgment time for detection of the reverse rotation warning (L70).
P49	SWTM	Start acceptance wait time	Sets the time from receiving a start command to actually initiating the start.
P50	OTUS	(Reserved for the system)	This is reserved for the system.
P51	OTAM	(Reserved for the system)	This is reserved for the system.
P52	OTAT	(Reserved for the system)	This is reserved for the system.
P53	OTWN	(Reserved for the system)	This is reserved for the system.
P54	OTWT	(Reserved for the system)	This is reserved for the system.
P55	WN_L	Motor electronic thermal relay overload warning threshold value	Sets the threshold value for the motor electronic thermal relay overload warning.

3.2 Internal mode

Item	Code	Name	Details
H00	—	Electrical current command rate	Displays the commanded electrical current as a percentage of the maximum electrical current.
H01	—	Motor load rate	Displays the load as a percentage of the motor current rating.
H02	—	Electrical current phase command value	Displays the electrical current phase command value.
H03	—	(Reserved for the system)	
H04	—	(Reserved for the system)	
H05	—	(Reserved for the system)	
H06	—	(Reserved for the system)	
H07	—	Changed items display	Displays parameters in the range P00 to P08 that have set values different from the factory defaults.
H08	—	Transition to alarm mode	Enables checking of the following details of alarms that have occurred previously.
H09	L_KP	(Reserved for the system)	
H10	V_KP	(Reserved for the system)	
H11	V_KI	(Reserved for the system)	
H12	S_TM	Surgeless start time	Same as parameter "P32 : Surgeless start time"
H13	L_IN	(Reserved for the system)	
H14	AC_M	(Reserved for the system)	
H15	VR Q	(Reserved for the system)	
H16	QMIN	Restriction value for minimum rotation speed command	Sets the lower limit value for rotation speed in the pressure control range when computing power deviation in PQ control calculations.
H17	PMIN	Restriction value for minimum pressure	Sets the lowest pressure for deviation calculations.
H18	PS_D	Pressure sensor correction factor	Corrects the pressure value at the maximum input voltage.
H19	—	(Reserved for the system)	—
H20	FLOC	Lock for panel setting change	Restricts the set parameters that can be edited.
H21	—	(Reserved for the system)	—
H22	—	(Reserved for the system)	—
H23	—	(Reserved for the system)	—
H24	—	(Reserved for the system)	—
H25	L_TI	PQ integration gain correction factor	Sets the integration gain correction factor for PQ control.

5 Settings at Part Replacement

Item	Code	Name	Details
H26-46	H_KP	(Reserved for the system)	—
H47	AM_T	Alarm measurement: Sampling time	Alarm measurement: Sampling time
H48	AMD1	Alarm measurement: Data 1	Alarm measurement: Data 1
H49	AMD2	Alarm measurement: Data 2	Alarm measurement: Data 2
H50	AMD3	Alarm measurement: Data 3	Alarm measurement: Data 3
H51	DHSL	L67: Holding pressure speed drop warning judgment Pressure offset	Sets the offset for the pressure threshold value for judging L67: Holding pressure speed drop warning.
H52	TVMR	Maintenance request	When E66 (motor temperature rise due to pressure holding speed drop) occurs, "1" is set.
H53	MTLH	Motor abnormal temperature threshold	Setting "0" disables this setting and the default set value is used as the threshold.
H54	RT_O	Reverse rotation warning judgment pressure	Sets the pressure for judging the reverse rotation warning.
H56	LG_L	Constant horsepower command	Sets a percentage relative to the power curve's reference value.
H57	LGOL	Constant horsepower command offset	Sets the offset for the commanded rotation speed at the maximum pressure point.

4 Supplementary List of Default Settings for Writing to the Main PCB

Setting mode

			EHU1404	EHU2504	EHU2507	EHU3007
P00	DI_A	Start/stop signal switching	1	1	1	1
P01	SW_L	Pressure switch	0	0	0	0
P02	T_SW	Pressure switch output delay time	0	0	0	0
P03	PSWH	Hold setting for pressure switch indication	0	0	0	0
P04	DS_P	Unit selection of pressure	0	0	0	0
P05	K_RT	(Reserved for the system)	50	50	50	50
P06	D_RT	(Reserved for the system)	0	0	0	0
P07	WN_M	(Reserved for the system)	0	0	0	0
P08	AMIX	(Reserved for the system)	1	1	1	1
P09	INIF	Initialize to default setting	0	0	0	0
P10	L_TI	PQ integration time correction factor	100	100	100	100
P11	M_VR	(Reserved for the system)	33	33	33	33
P12	W_TM	(Reserved for the system)	0	0	0	0
P13	PL.0	Pressure setting	15	15	15	15
	QL.0	Flow volume setting	3800	4400	4400	5000
P14-P28		(Reserved for the system)				
P29	C_TM	(Reserved for the system)	0	0	0	0
P30	DF_N	(Reserved for the system)	0	0	0	0
P31	P_SN	Pressure sensor rated value	10	10	10	10
P32	S_TM	Surgeless start time	50	50	50	50
P33	L_IN	(Reserved for the system)	10	10	10	10
P34	E_TM	(Reserved for the system)	200	200	200	200
P35	DR_L	Dry operation judgment pressure	50	50	50	50
P36	DR_T	Dry operation judgment time	300	300	300	300
P37	SM_R	(Reserved for the system)				
P38	P_DF	No detection zone of pressure switch	50	50	50	50
P39	DO_S	Digital output selection	8	8	8	8
P40	PL_D	(Reserved for the system)	0	0	0	0
P41	PCMW	(Reserved for the system)	5	5	5	5
P42	PCMM	(Reserved for the system)	1	1	1	1
P43	QCMW	(Reserved for the system)	5	5	5	5
P44	QCMM	(Reserved for the system)	2	2	2	2
P45	AC_F	Cooling fan motor rotation speed	0	0	0	0
P46	TVMJ	Maintenance implementation review enable/disable	0	0	0	0
P47	RMOT	Alarm relay output maintenance notification enable/disable	0	0	0	0
P48	T_SP	Reverse rotation warning judgment time	5	5	5	5
P49	SWTM	Start acceptance wait time	0	0	0	0
P50	OTUS	(Reserved for the system)	0	0	0	0
P51	OTAM	(Reserved for the system)	0	0	0	0
P52	OTAT	(Reserved for the system)	20	20	20	20
P53	OTWN	(Reserved for the system)	0	0	0	0
P54	OTWT	(Reserved for the system)	100	100	100	100
P55	WN_L	Motor electronic thermal relay overload warning threshold value	105	105	105	105

5 Settings at Part Replacement

Internal mode

			EHU1404	EHU2504	EHU2507	EHU3007
H00	—	Electrical current command rate				
H01	—	Motor load rate				
H02	—	Electrical current phase command value				
H03	—	(Reserved for the system)				
H04	—	(Reserved for the system)				
H05	—	(Reserved for the system)				
H06	—	(Reserved for the system)				
H07	—	Changed items display				
H08	—	Transition to alarm mode				
H09	L_KP	(Reserved for the system)	25	25	15	15
H10	V_KP	(Reserved for the system)	500	500	500	500
H11	V_KI	(Reserved for the system)	120	120	120	120
H12	S_TM	Surgeless start time	50	50	50	50
H13	L_IN	(Reserved for the system)				
H14	AC_M	(Reserved for the system)	268	268	268	268
H15	VR Q	(Reserved for the system)	100	0	0	0
H16	QMIN	Restriction value for minimum rotation speed command	600	600	600	600
H17	PMIN	Restriction value for minimum pressure	800	800	800	800
H18	PS_D	Pressure sensor correction factor	15	15	15	15
H19	—	(Reserved for the system)				
H20	FLOC	Lock for panel setting change	0	0	0	0
H21	—	(Reserved for the system)				
H22	—	(Reserved for the system)				
H23	—	(Reserved for the system)				
H24	—	(Reserved for the system)				
H25	L_TI	PQ integration gain correction factor	100	100	100	100
H26-46	H_KP	(Reserved for the system)				
H47	AM_T	Alarm measurement: Sampling time	0	0	0	0
H48	AMD1	Alarm measurement: Data 1	0	0	0	0
H49	AMD2	Alarm measurement: Data 2	0	0	0	0
H50	AMD3	Alarm measurement: Data 3	0	0	0	0
H51	DHSL	L67: Holding pressure speed drop warning judgment Pressure offset	20	20	20	20
H52	TVMR	Maintenance request	0	0	0	0
H53	MTLH	Motor abnormal temperature threshold	0	0	0	0
H54	RT_O	Reverse rotation warning judgment pressure	50	50	50	50
H56	LG_L	Constant horsepower command	35	25	31	70
H57	LGOL	Constant horsepower command offset	0	0	0	150

1 List of Annexes (Work Procedures Manuals)

Annex	Name of Procedures Manual	No.	Page
1	ECORICH (No. 40 Design) Controller Replacement Procedure	PE02455	92
2	ECORICH (No. 40 Design) Motor Pump Replacement Procedure	PE02456	95
3	ECORICH (No. 40 Design) Motor Replacement Procedure	PE02457	97
4	ECORICH (No. 40 Design) Pressure Sensor/Safety Valve Replacement Procedure	PE02458	98
5	ECORICH (No. 40 Design) Pressure Sensor Connector Connection Check Procedure	PE02460	102
6	ECORICH (No. 40 Design) DC Fan Harness Connector Connection Check Procedure	PE02461	104
7	ECORICH (No. 40 Design) Pressure Sensor/DC Fan Harness Replacement Procedure	PE02462	106
8	ECORICH (No. 40 Design) DC Fan and Oil Cooler Cleaning/Replacement Procedure	PE02463	108
9	ECORICH (No. 40 Design) Suction Strainer Cleaning/Replacement Procedure	PE02465	111
10	ECORICH (No. 40 Design) Hydraulic Oil Change Procedure	PE02466	114
11	ECORICH (No. 40 Design) DC Fan Motor Fuse Replacement Procedure	PE02468	115
12	ECORICH (No. 40 Design) Motor Coil/Power Device Resistance Measurement Procedure	PE02490	116
13	ECORICH (No. 40 Design) Input Power/Ground Fault Check Procedure	PE02491	118
14	ECORICH (No. 40 Design) Controller PCB Replacement Procedure	PE02499	120
15	ECORICH (No. 40 Design) Harness Connection Check Procedure	PE02505	126
16	ECORICH (No. 40 Design) Variable Relief Pressure/Minimum Rotation Speed Adjustment Procedure	PE02506	130

6 Annexes (Work Procedures Manuals)

No. PE-02455

October 18, 2016

Technical Data		Data Classification	Approved by	Checked by	Responsible Person
			C		
Date Created	June 24, 2016				
Title	ECORICH (No. 40 Design) Controller Replacement Procedure				
Purpose	To summarize the replacement procedures for ECORICH (No. 40 Design).				

Tools Required

- Cross head screwdriver
- Small torque screwdriver (Cross head)
- Pliers
- Lock nut loosening/tightening tool

- 1) Loosen the controller exterior cover's fixing screws (4-M4, tightening torque: 1 N·m) and remove the exterior cover.

1

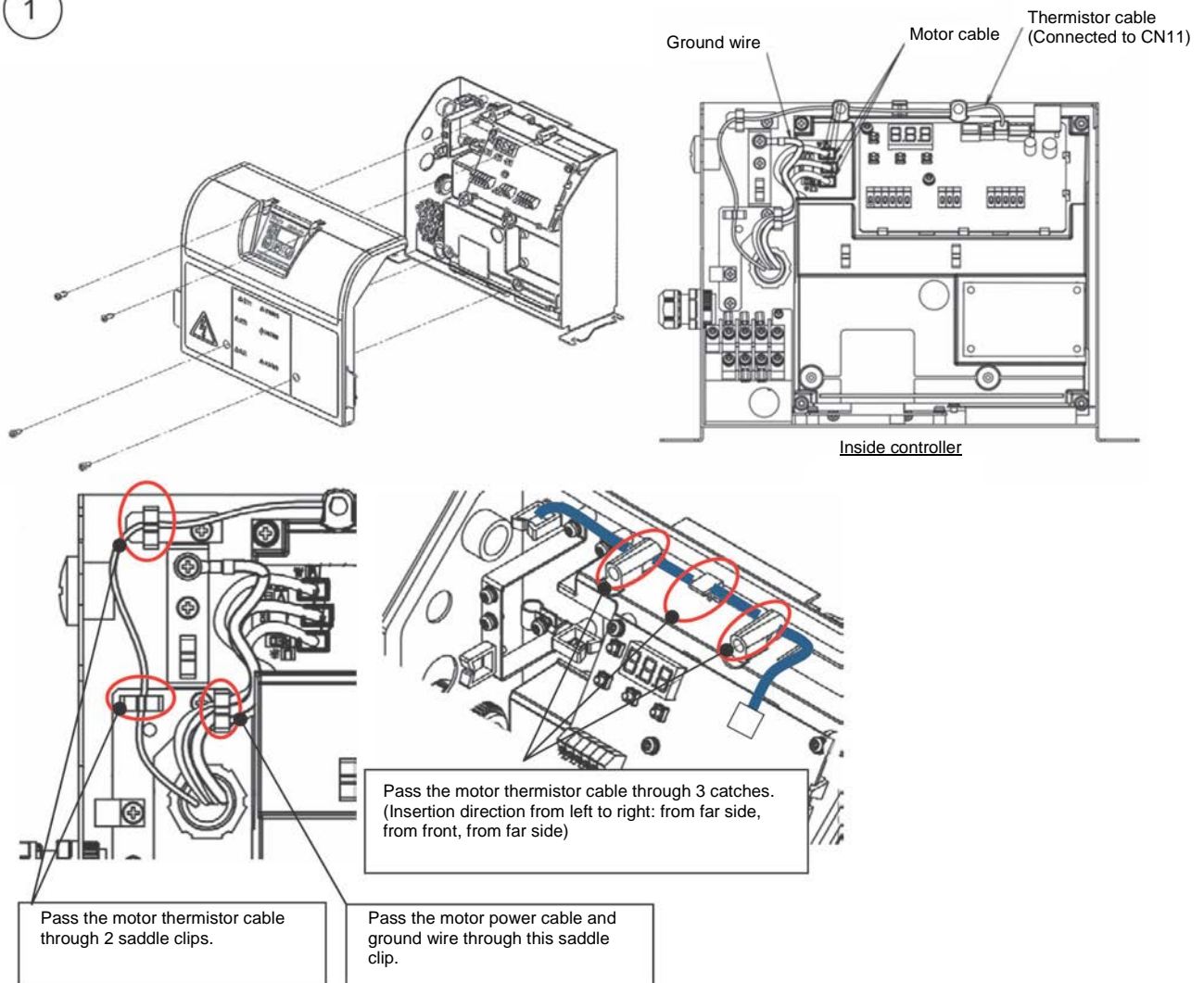

Route of motor thermistor harness

Remove the motor power cable, motor thermistor cable (connected at connector number CN11 on the interface PCB) and ground wire (1-M4, tightening torque: 1 N·m) inside the controller.

- * Note: When fitting, fit the motor thermistor cable, then the motor power cable in accordance with the harness routing diagram.

- 2) Loosen the hose clamp at the oil cooler side, then pull the connected hose off.
 - * Note: When the hose is pulled off oil will drip out, so wipe it up with a rag cloth.
 - * Note: When connecting the hose, pass it on as far as the coated part.
- 3) Loosen the fixing screws (2-M4, tightening torque: 1 N·m) for the cover and CR stay.

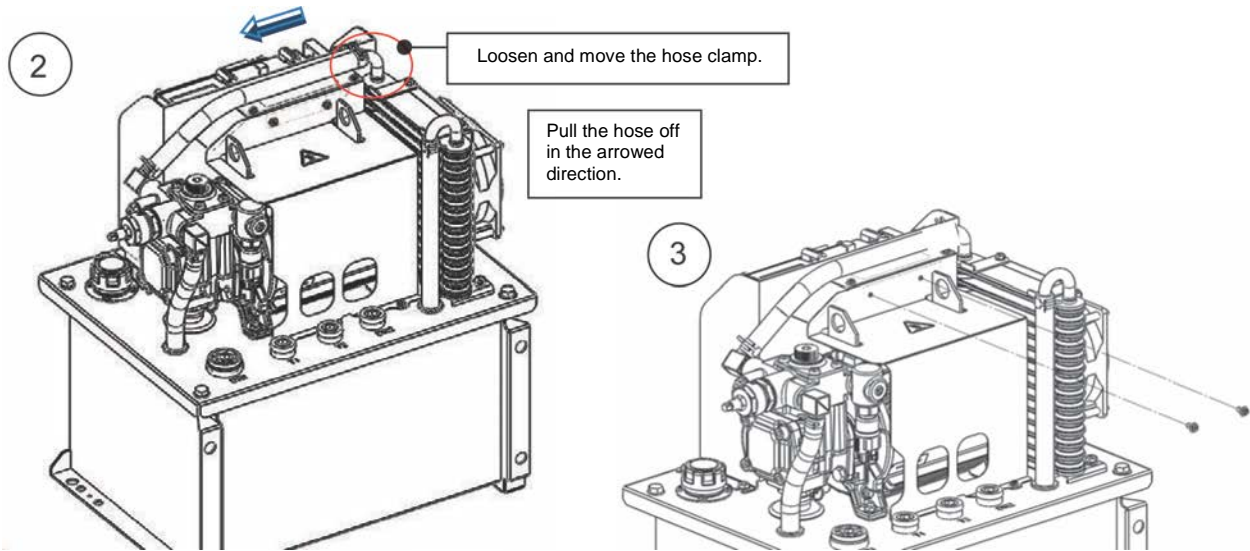

- 4) Loosen the cover's fixing screws (5-M4, tightening torque: 1 N·m) and remove the cover.
- 5) Loosen the fixing screws (2-M4 hexagon socket head cap screws, tightening torque: 3.4 N·m) of the CR stay and controller.

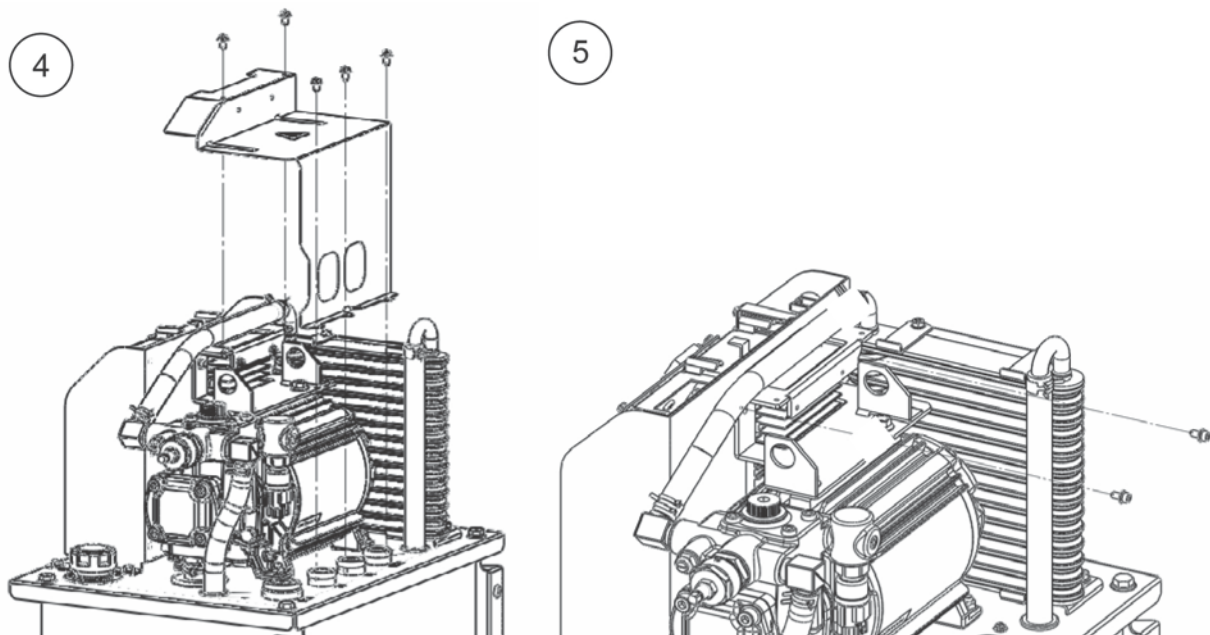

6 Annexes (Work Procedures Manuals)

- 6) Disconnect the pressure sensor's connector, and remove the harness fixed to the suction pipe with an omega clip.
- 7) Remove the harness by pulling the connector out between the suction pipe and motor.

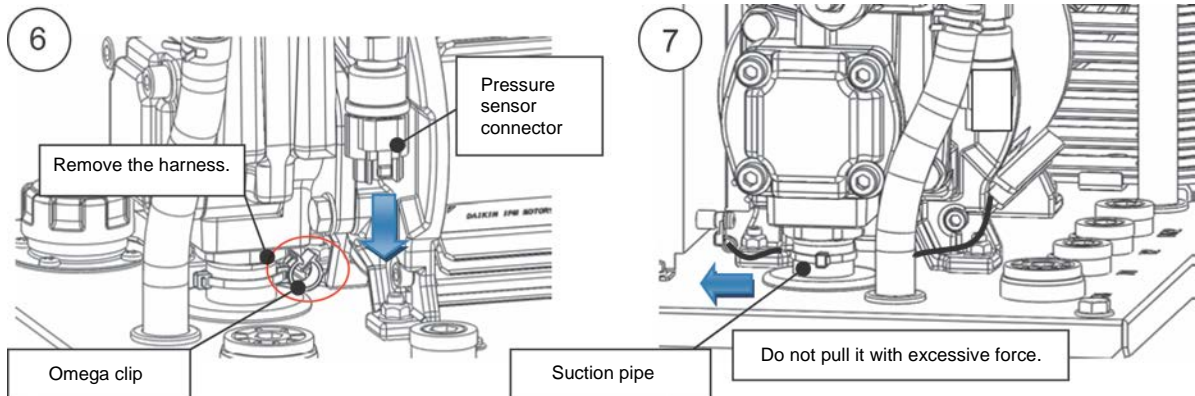

- 8) Loosen and remove the fixing screws (4-M6, tightening torque: 5 N·m) for the controller and top plate.
 - 9) Disconnect the DC fan's connector, loosen the lock nut (tightening torque: 1 N·m), then pull the controller toward the front and remove it.
- Take care not to damage the motor power cable or motor thermistor during the work.

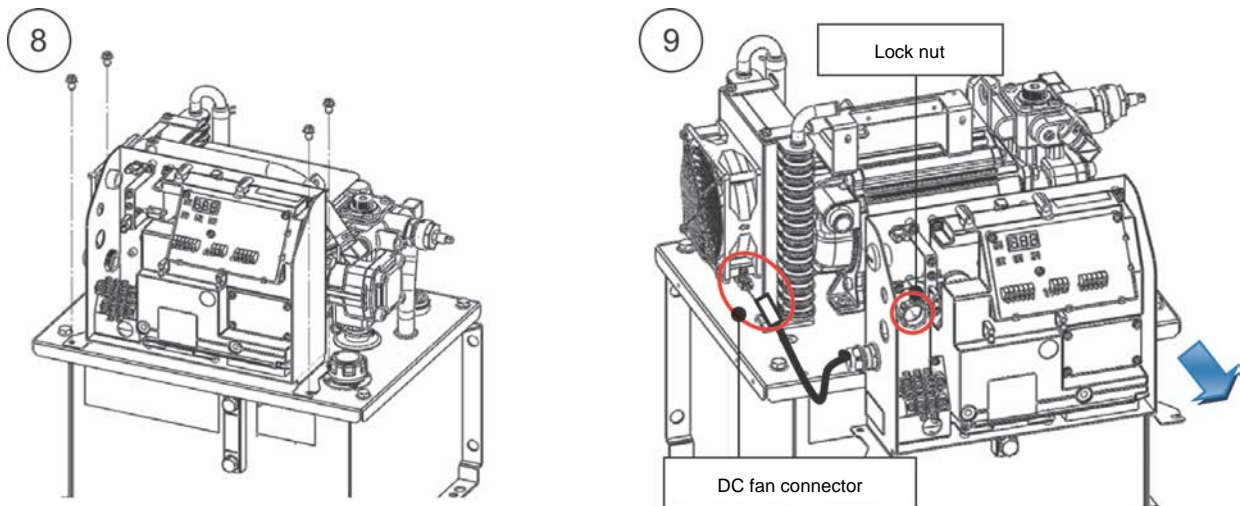

No. PE-02456

October 18, 2016

Technical Data		Data Classification	Approved by	Checked by	Responsible Person
		C			
Date Created	June 24, 2016				
Title	ECORICH (No. 40 Design) Motor Pump Replacement Procedure				
Purpose	To summarize the motor pump replacement procedures for ECORICH (No. 40 Design).				

Tools Required

- Torque wrench (5 N·m, 7 N·m, 10 N·m)
- Nippers, pliers, spanners (width across flats: 10 mm, 12 mm)
- Adjustable wrench (width across flats: 34 mm)
- Adhesive (ThreeBond product No. 1544F)

- 1) Remove the controller in accordance with the ECORICH (No. 40 Design) Controller Replacement Procedure (Technical Data PE02455).
- 2) Loosen the fixing screws (2-M8, tightening torque: 9 N·m) for the motor and CR stay, and remove the stay.

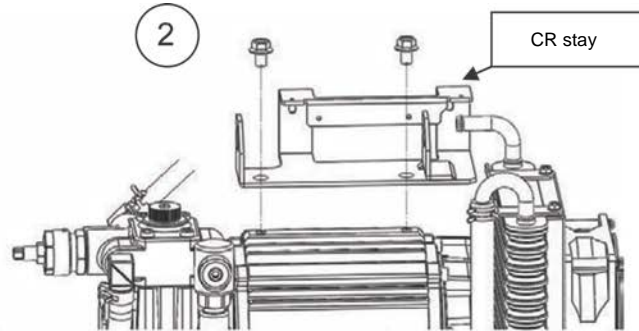
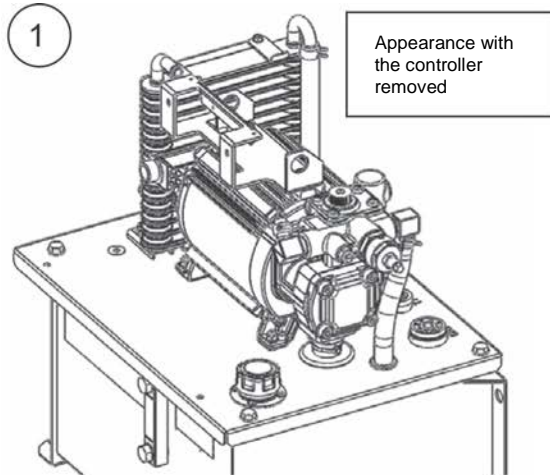

- 3) Loosen the hose clamp at the tank return ports side and pull the hose out in the downward direction.
- 4) Cut the omega clip fitted on the suction pipe with nippers and remove it.
 - * Note: It cannot be re-used. Fit a new one as the replacement.

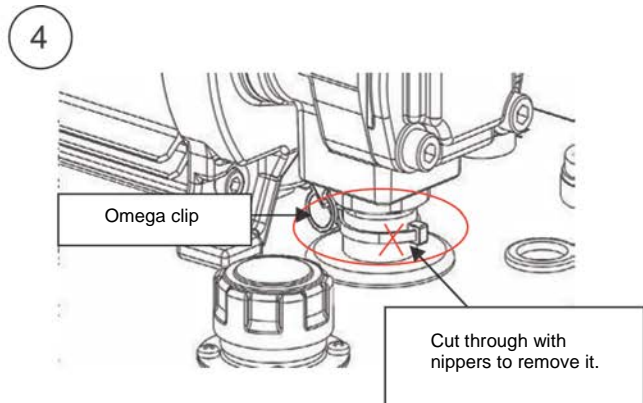
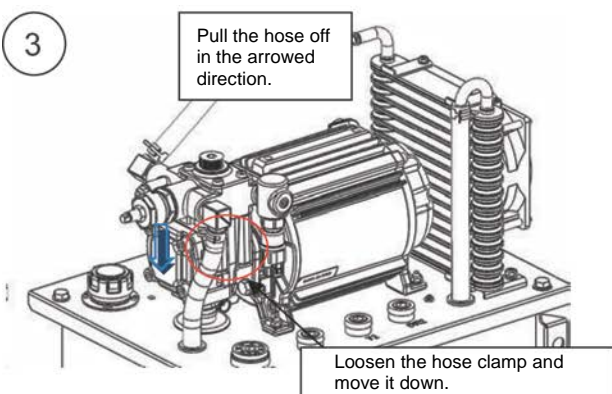

6 Annexes (Work Procedures Manuals)

- 5) Turn the suction pipe with an adjustable wrench to loosen. Unscrew the threaded section and move it downward.
- 6) Loosen and remove the Three Lock Nuts (4-M6, tightening torque: 9 N·m) in the motor foot.

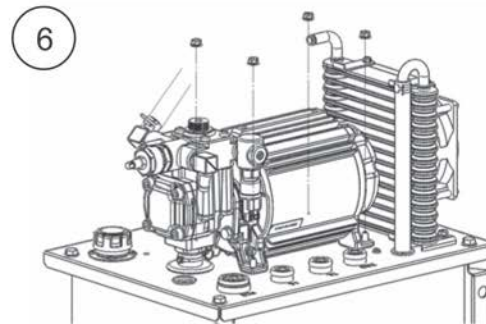
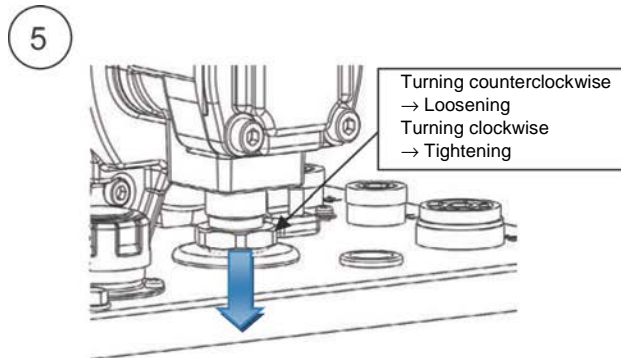

- 7) Lift up the motor (approx. 10 kg).
- 8) There is foreign matter (adhesive) stuck to the threaded part of the suction pipe, so clean it off. Check that there is no oil adhering to the flange section of the suction pipe, and apply adhesive all around the section shown in the figure. Screw the suction pipe into the threaded section of the new motor pump and tighten it at the stipulated torque (tightening torque: 7 N·m). It is not necessary to wipe away extruded adhesive.
* Note: Tightening in excess of the stipulated torque will cause breakage.

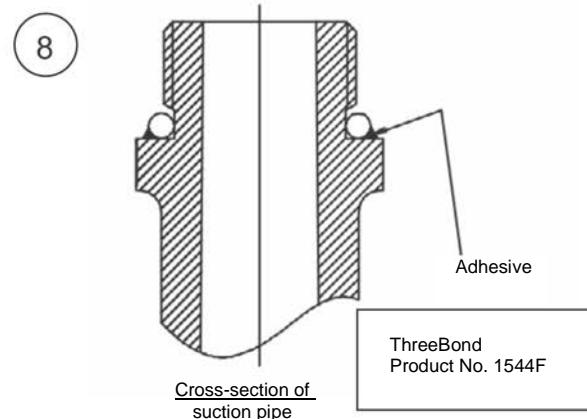
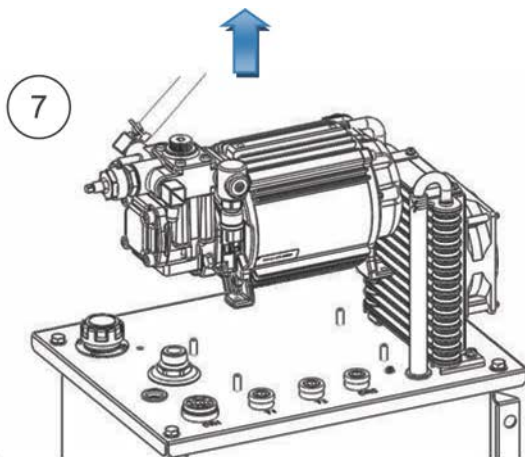

Do the fitting work by implementing the procedure in reverse, from step 7 to 1.

No. PE-02457

October 18, 2016

Technical Data		Data Classification	Approved by	Checked by	Responsible Person
			C		
Date Created	June 24, 2016				
Title	ECORICH (No. 40 Design) Motor Replacement Procedure				
Purpose	To summarize the motor and pump replacement procedures for ECORICH (No. 40 Design).				

Tools Required

- Spanner (width across flats)
- Torque wrench (12 N·m)

- 1) Remove the motor pump from the unit in accordance with the ECORICH (No. 40 Design) Motor Pump Replacement Procedure (Technical Data PE02456)

1

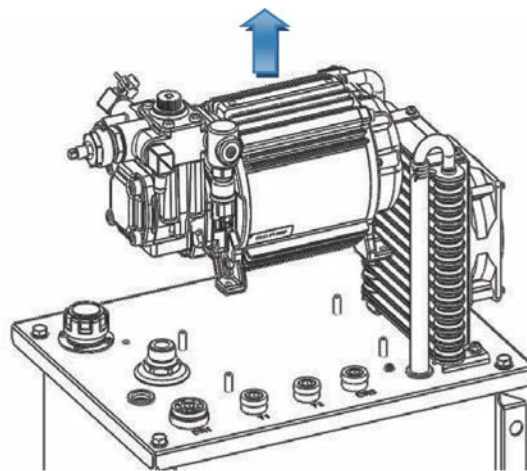

- 2) Loosen the fixing screws (2-M8, tightening torque: 12 N·m) for the motor and pump, and pull out the pump.

If it is difficult to pull out, it can be pulled out easily by using the optional tool “ES-PUMPJIGU-1”.

* Note: When fitting, apply grease to the pump’s shaft before inserting it in order to prevent seizure.

Recommended grease: Shell Stamina Grease RL2

* Be sure to fit the key that comes with the pump.

2

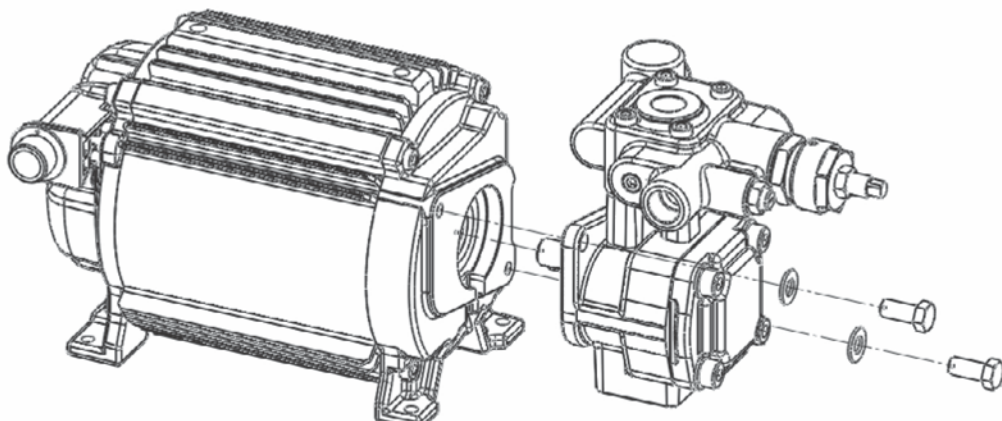

6 Annexes (Work Procedures Manuals)

No. PE-02458

October 18, 2016

Technical Data		Data Classification	Approved by	Checked by	Responsible Person
		C			
Date Created	June 24, 2016				
Title	ECORICH (No. 40 Design) Pressure Sensor/Safety Valve Replacement Procedure				
Purpose	To summarize the pressure sensor and safety valve replacement procedures for ECORICH (No. 40 Design).				

<Removing/mounting the pressure sensor>

<Removing the pressure sensor>

Tools Required

- Adjustable wrench (width across flats: 22 mm)
- Torque wrench (41 N·m)

- 1) Remove the connector connected to the pressure sensor.
Take care not to pull on the harness since this will risk breaking its wires.
- 2) Turn the hexagonal section (width across flats: 22 mm) of the pressure sensor with a tool such as an adjustable wrench, and remove the pressure sensor.
Engage the hexagonal part. Engaging any other part will break the pressure sensor.

<Preparing the sensor>

- 1) Check if the new pressure sensor has an O-ring fitted on its threaded mount.
Apply grease to the O-ring to prevent its breakage during mounting.

<Mounting the pressure sensor>

- 2) Mount the pressure sensor on the safety valve.
Be sure to engage the hexagonal part for tightening.
(Tightening torque: 41 N·m)

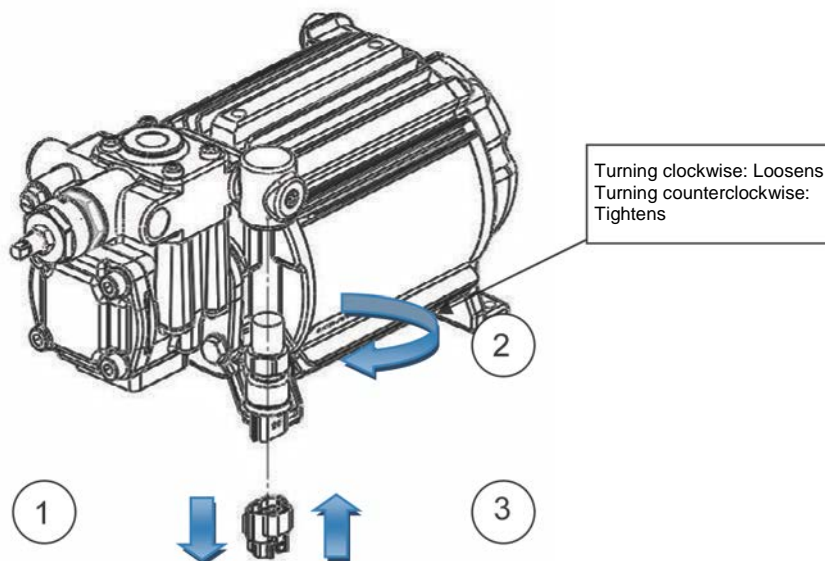

<Fitting the connector>

- 3) Fit the connector to the pressure sensor.
Insert it firmly until a click is heard.

<Removing/mounting the safety valve>

Tools Required

- Pliers
- Hexagonal wrench (width across flats: 5 mm)
- Torque wrench (10 N·m)

<Removing the pressure sensor>

- 1) Disconnect the pressure sensor connector and remove the pressure sensor from the safety valve in the manner described in the previous section.

<Removing the drainage hose>

- 2) Nip the grip part of the hose clamp with pliers, and loosen it between the hose and joint.

Move the hose clamp toward the hose side and pull the drainage hose off.

* When the hose is pulled off, oil will leak. Contain the leakage with a rag cloth.

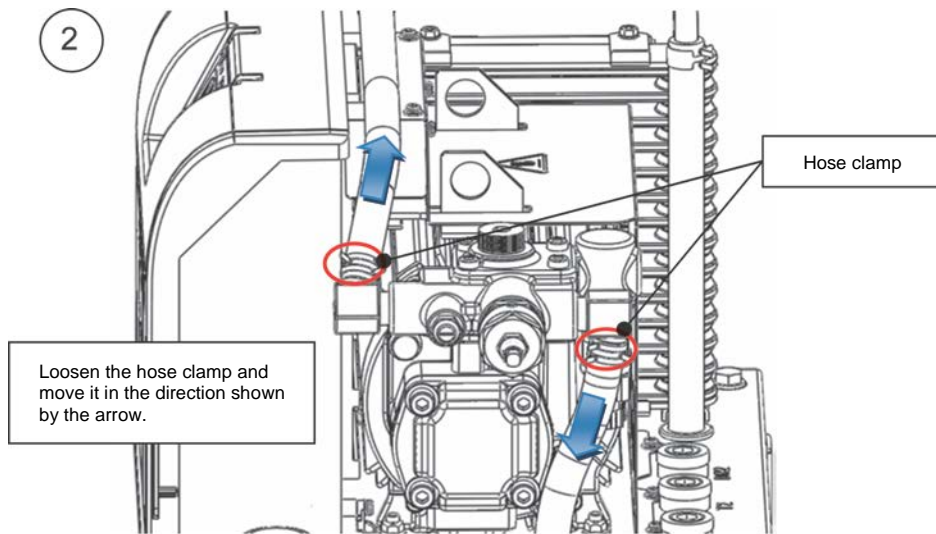

<Removing the safety valve>

- 3) Loosen the fixing screws (4-M6 hexagon socket head cap screws, tightening torque: 10 N·m) that secure the safety valve to the pump to complete the detachment.

* When the relief block is removed, oil will leak. Contain the leakage with a rag cloth.

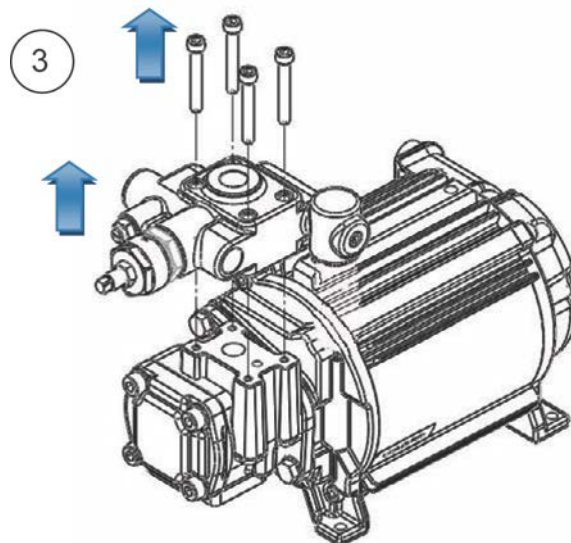

6 Annexes (Work Procedures Manuals)

1) Preparing the new relief valve

Check if two O-rings, one small and one large, are fitted at the rear face on the new relief valve.

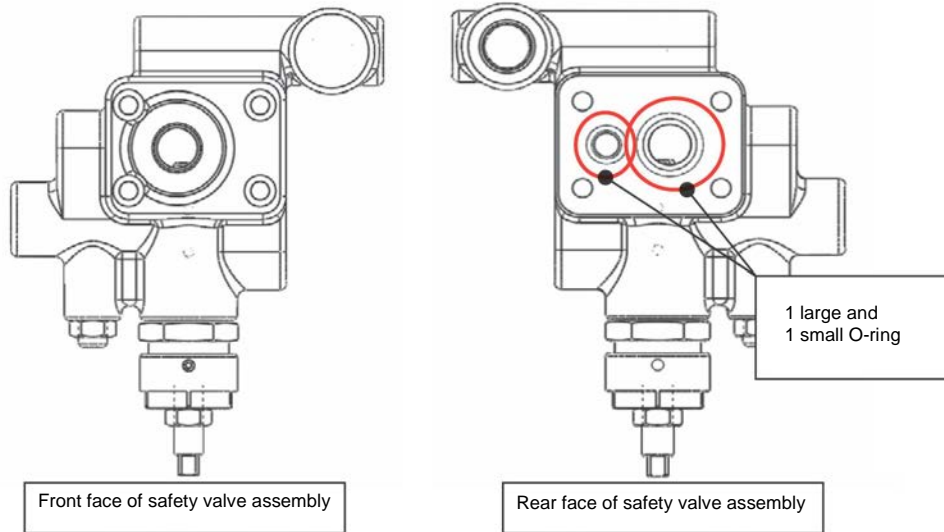

2) Secure the safety valve to the pump by using the fixing screws (4-M6 hexagonal socket head cap screws, tightening torque: 10 N·m) that were used originally.

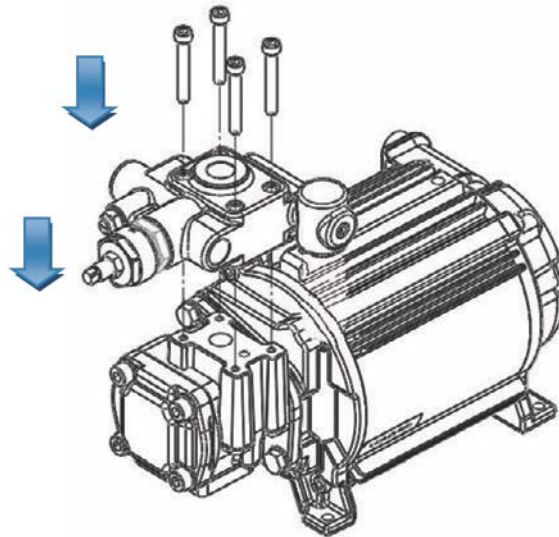

3) Fitting the drainage hose

Take the drainage joints off the old relief valve, wrap sealing tape around their threaded section, and fit them to the new relief valve.

Regarding the orientation of the joints, there is a marking on their side faces: adjust the orientation while checking the angle of this marking.

After adjusting the angle, check that two or three ridges of the joint's thread remain exposed.

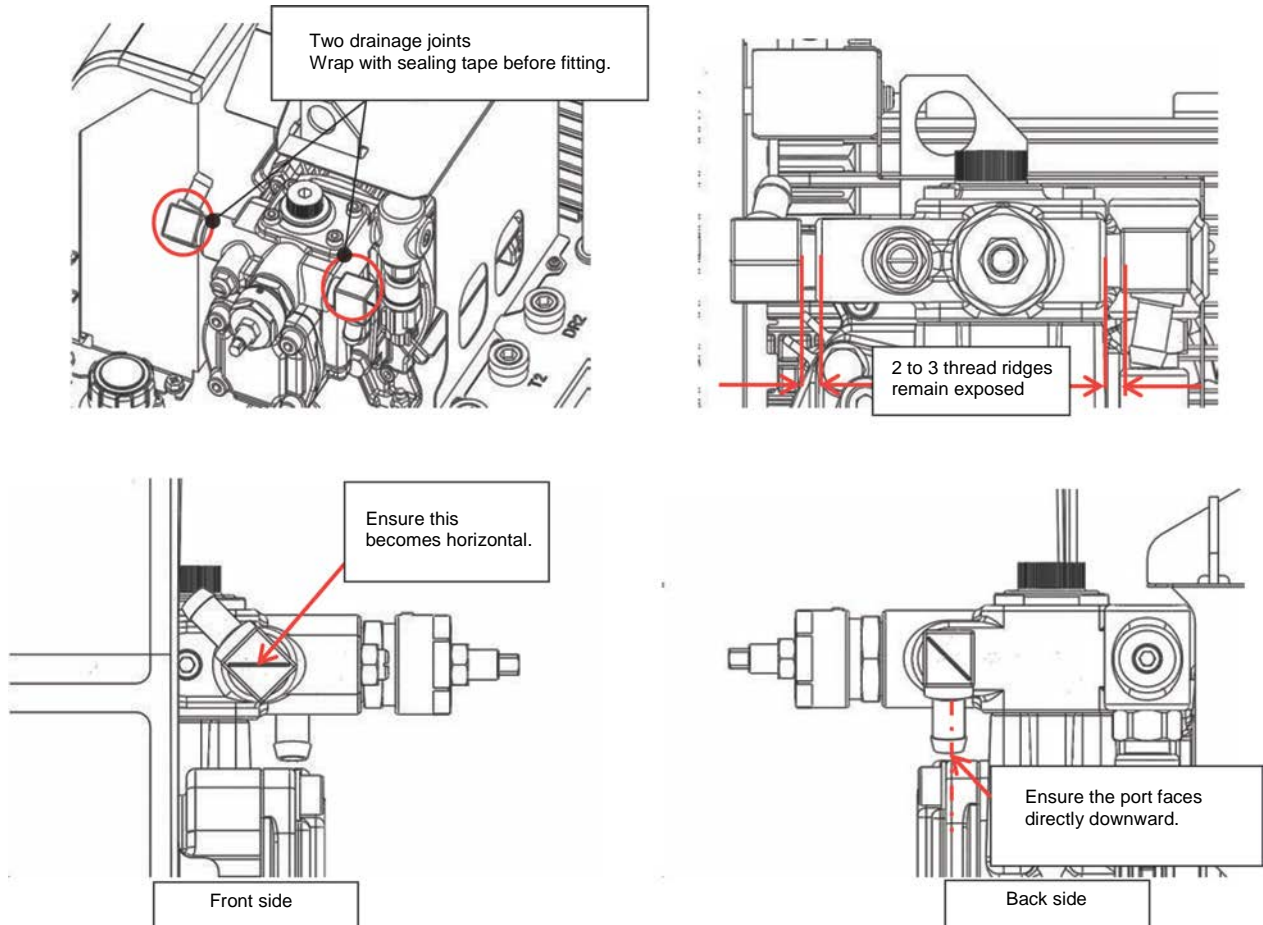

Hold the drainage hose on the drainage joint and secure it with the hose clamp.

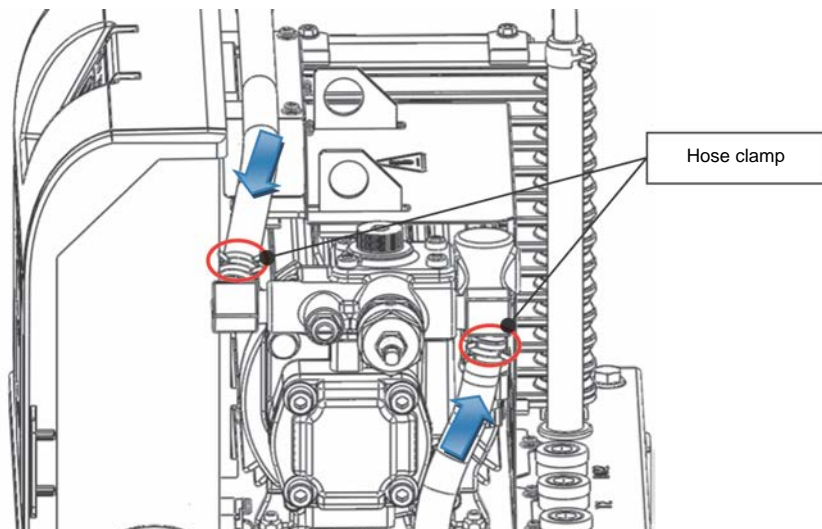

Installing the pressure sensor

4) Install the pressure sensor and pressure sensor harness in the manner described in the previous section.

6 Annexes (Work Procedures Manuals)

No. PE-02460

October 18, 2016

Technical Data		Data Classification	Approved by	Checked by	Responsible Person
			C		
Date Created	June 24, 2016				
Title	ECORICH (No. 40 Design) Pressure Sensor Connector Connection Check Procedure				
Purpose	To summarize the procedure for checking the connection of the pressure sensor connector for ECORICH (No. 40 Design).				

<Checking for wire breakage of the pressure-sensor-side harness>

- 1) The pressure sensor harness is secured on the rear of the controller, and it passes close to the suction pipe and is connected to the pressure sensor, which is connected to the valve block.

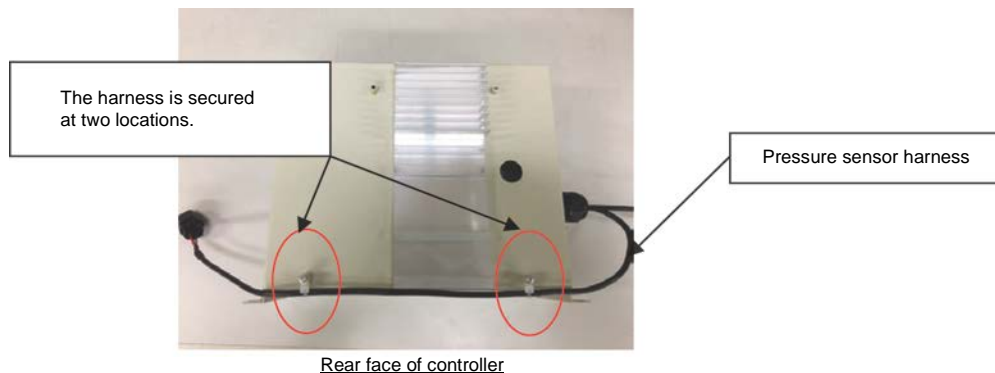

- 2) Visually check that there is no external damage to the harness.
If there is serious damage such as exposure of the core wires, replace the harness.

<Checking connection of the controller-side connector>

If there is no wire breakage in the harness, check its connection with the internal connector (CN6 on the interface PCB).

- 3) Loosen the screws (4-M4, tightening torque: 1 N·m) of the controller's exterior cover, and remove the cover.
- 4) To check the connection, disconnect the connector connected to CN6 on the interface PCB.
(Disconnect this connector while pressing its latch. Pulling on the harness part may cause wire breakage.)
Check if any connector pin is disconnected from the connector, and if any is disconnected, insert it firmly and fully home.

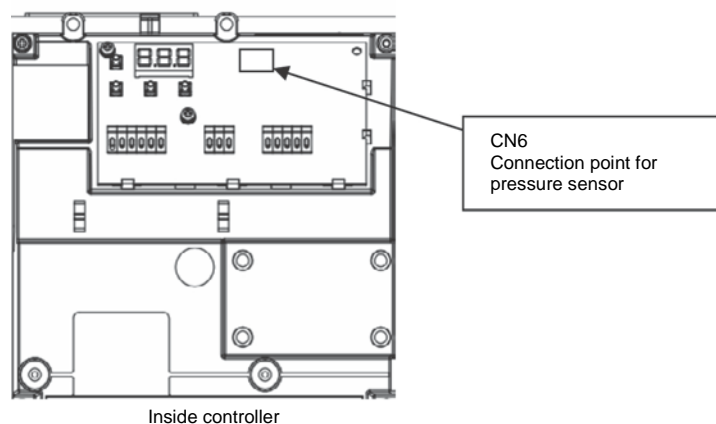

- 5) Check continuity with a circuit tester, referring to the figure below. If there is a broken wire, the harness has to be replaced.

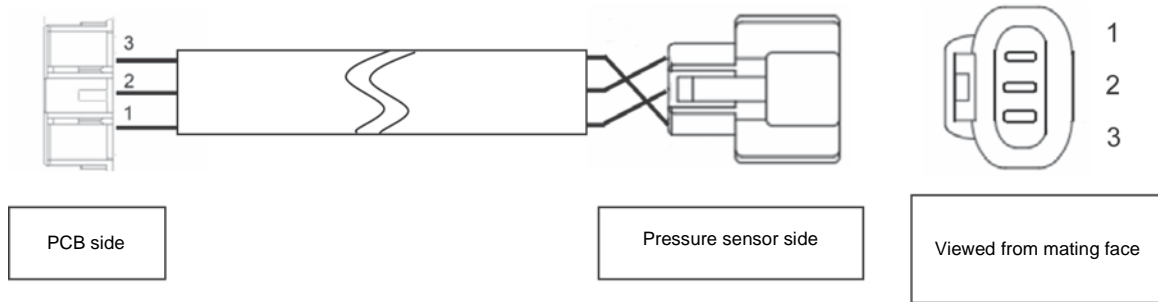

Pin No.		Wire color
PCB side	Pressure sensor side	
1	2	Black
2	1	Red
3	3	Black/White

Pressure sensor harness connection diagram

- 6) Return the harness as it was (refer to PE02505 ECORICH (No. 40) Design Harness Connection Check Procedure) and tighten the screws (4-M4, tightening torque: 1 N·m) of the controller's exterior cover.

6 Annexes (Work Procedures Manuals)

No. PE-02461

October 18, 2016

Technical Data		Data Classification	Approved by	Checked by	Responsible Person
			C		
Date Created	June 24, 2016				
Title	ECORICH (No. 40 Design) DC Fan Harness Connector Connection Check Procedure				
Purpose	To summarize the procedure for checking the connection of the DC fan harness connector for ECORICH (No. 40 Design)				

<Checking for wire breakage of the DC fan harness>

- 1) The DC fan harness is led out from the left side face of the controller, is relayed by a connector close to the DC fan, and then connected to the DC fan.
- 2) Visually check that there is no external damage to the harness.
If it has external damage that makes it unusable, the harness must be replaced.

<Checking connection of the controller-side connector>

- 3) If there is no wire breakage in the harness, check its connection with the internal connector (CN7 on the interface PCB).
- 4) Loosen the screws (4-M4, tightening torque: 1 N·m) of the controller's exterior cover, and remove the cover.
- 5) To check the connection, disconnect the connector connected to CN7 on the interface PCB.
(Disconnect this connector while pressing its latch. Pulling on the harness part may cause wire breakage.)
Check if any connector pin is disconnected from the connector, and if any is disconnected, insert it firmly and fully home.

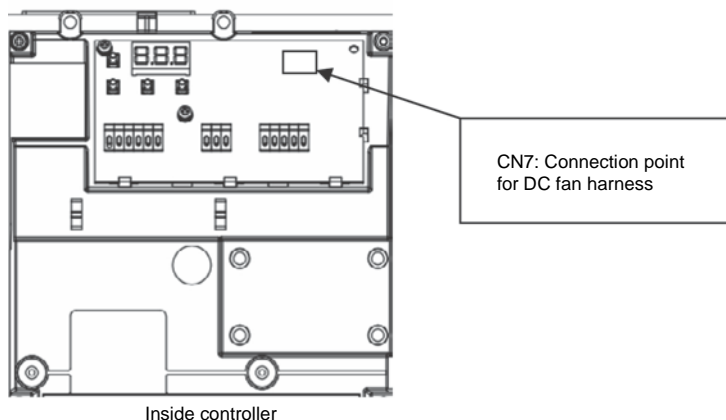

- 6) Check continuity with a circuit tester by referring to the figure below.
If there is a broken wire, the harness has to be replaced.

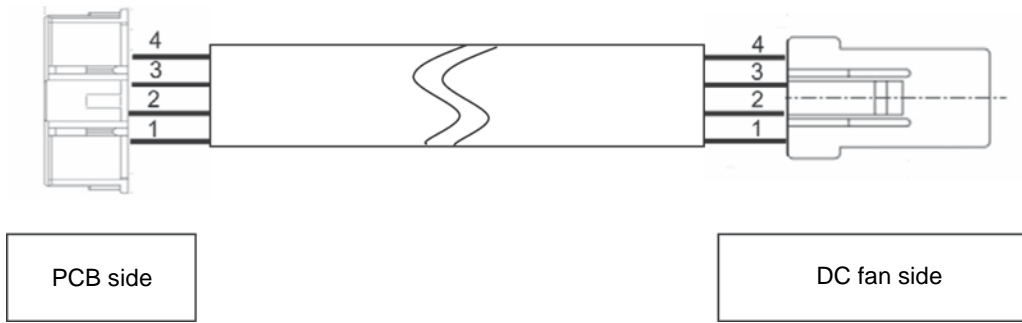

Pin No.		Wire color
PCB side	DC fan side	
1	1	Red
2	2	Green
3	3	Black
4	4	White

DC fan harness connection diagram

- 7) Return the harness as it was (refer to PE02505 ECORICH (No. 40 Design) Harness Connection Check Procedure) and tighten the screws (4-M4, tightening torque: 1 N·m) of the controller's exterior cover.

6 Annexes (Work Procedures Manuals)

No. PE-02462

October 18, 2016

Technical Data		Data Classification	Approved by	Checked by	Responsible Person
		C			
Date Created	June 24, 2016				
Title	ECORICH (No. 40 Design) Pressure Sensor/DC Fan Harness Replacement Procedure				
Purpose	To summarize the procedure for replacing the pressure sensor and DC fan harness for ECORICH (No. 40 Design)				

If the harness has been damaged it will be necessary to replace it.

Remove the controller in accordance with the ECORICH (No. 40 Design) Controller Replacement Procedure (PE02455).

<Removing the harness>

- 1) Loosen the screws fixed in the rear face of the controller (2-M4, tightening torque: 1 N·m), and remove the pressure sensor harness.
- 2) Disconnect the two connectors (CN6 and CN7 on the interface PCB) inside the controller.
 - * Note: Disconnect this connector while pressing its latch. Pulling on the harness part may cause wire breakage.

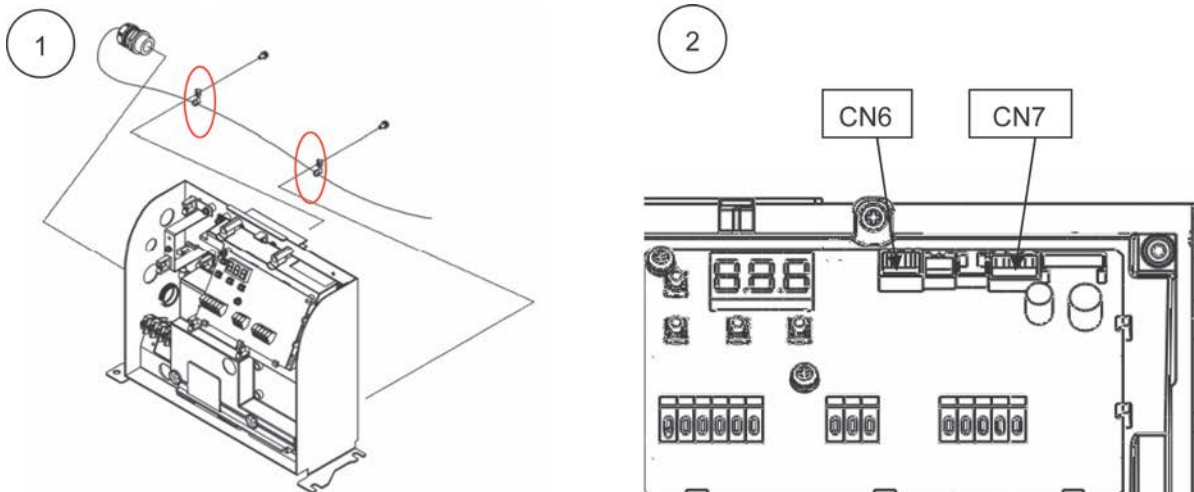

- 3) Loosen the screw (M4, tightening torque: 1 N·m) of the FG clamp shown in the figure.
 - * Note: The FG clamp will be re-used.
- 4) Loosen the cable clamp and remove the harness from the controller.

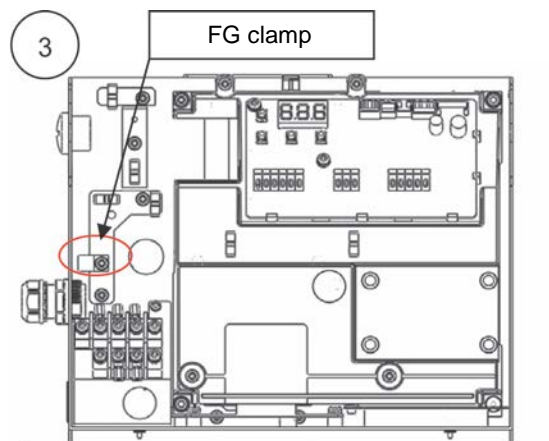

<Mounting>

Preparing the harness

- 1) Pass the harness through the hole ($\phi 23$) at the lowest position on the left side of the controller, and secure the cable clamp to the housing.
 - * Note: Fit the cable clamp itself at the exterior.
 - * Note: Lead the cables out as shown in figure (1) and fix them using the cable clamp.
 - * Note: When tightening the cable clamp, tighten it by hand and check that it does not come loose.

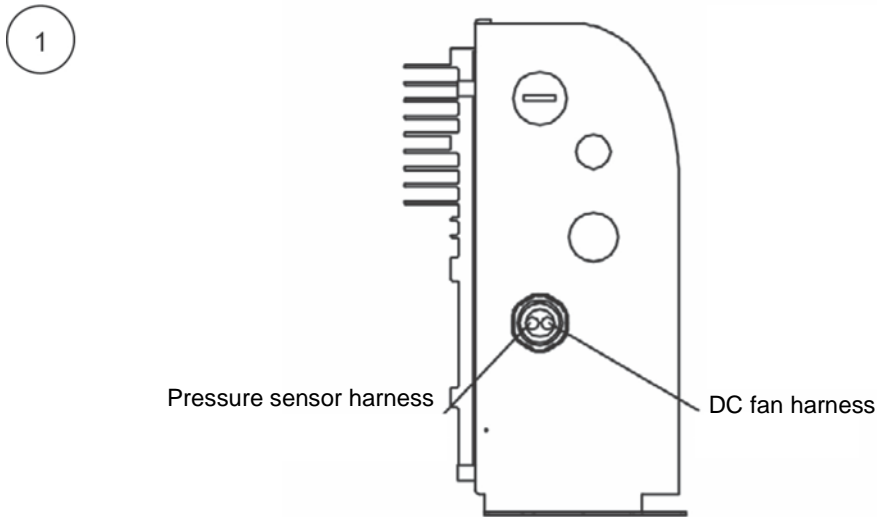

Leading out the cables through the cable clamp

- 2) As shown in the figure below, entrap the sheath of the harness at the pressure sensor side with the FG clamp, and secure it with the screw (M4, tightening torque: 1 N·m).
In addition, pass the two harnesses through saddle clips at 2 locations.

- 3) Route the cables inside the controller.
Route and secure the cables by referring to the figure.

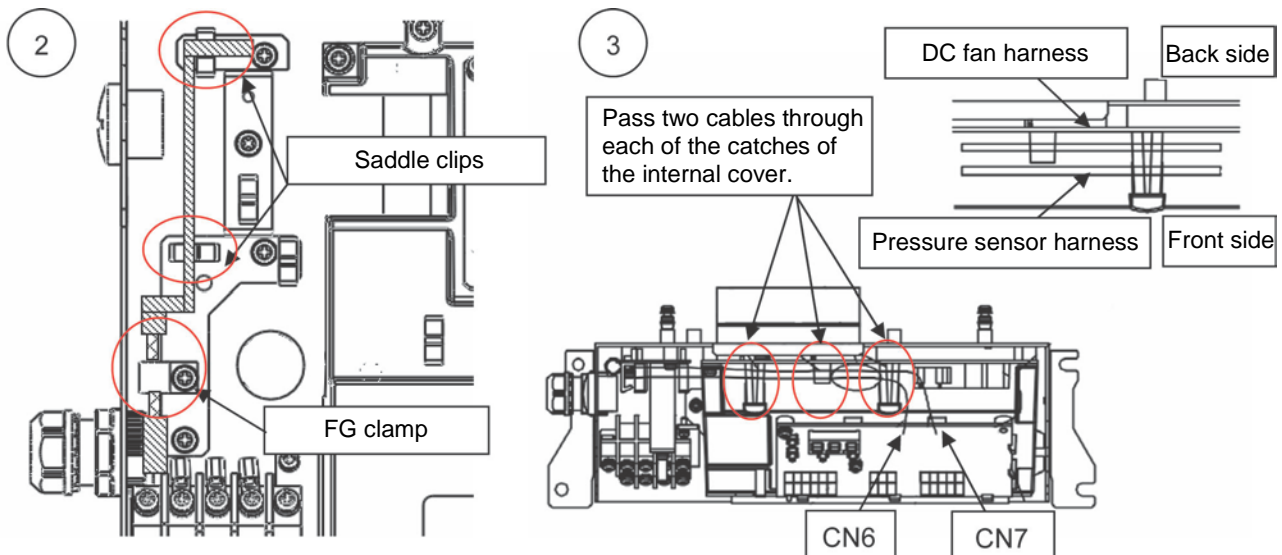

- 4) Connect the two connectors to CN6 and CN7 on the interface PCB.
Check that they click into place.
- 5) Tighten the screws (2-M4, tightening torque: 1 N·m) fixed in the rear face of the controller to fix the pressure sensor harness.

6 Annexes (Work Procedures Manuals)

No. PE-02463

October 18, 2016

Technical Data		Data Classification	Approved by	Checked by	Responsible Person
		C			
Date Created	June 24, 2016				
Title	ECORICH (No. 40 Design) DC Fan and Oil Cooler Cleaning/Replacement Procedure				
Purpose	To summarize the procedure for cleaning and replacing the DC fan and oil cooler for ECORICH (No. 40 Design)				

Tools Required

- Cross head screwdriver
- Torque screwdriver (1 N·m, 5 N·m)
- Pliers
- Rag cloth

<Precautions before starting work>

- Before starting the work, stop the unit operation and shut off the source power supply. Check that the fan is not rotating before starting the work.
- Wear protective glasses and gloves for this work. The fins of the oil cooler core are sharp, so take care. Also, when using air blow, take care to avoid getting foreign matter in your eyes.
- Take care to ensure that no excessive forces are applied to the fan motor, power cable or connectors during the work.
- Oil may come out of the piping or oil cooler during disassembly, so take care.

<Removing the oil cooler>

- 1) Remove the connector of the DC fan harness.
- 2) Remove the cross-recessed hexagon head bolts (2-M6, tightening torque: 5 N·m) that secure the tank top plate to the oil cooler legs.

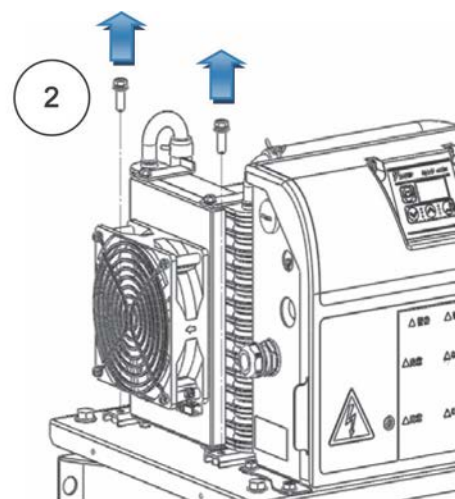
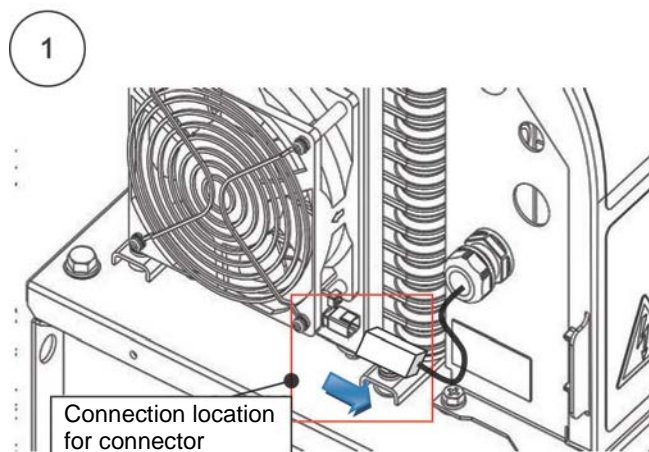

- 3) Nip the grip parts of the hose clamps with pliers to loosen the hose clamps and move each in the arrowed direction (two clamps).

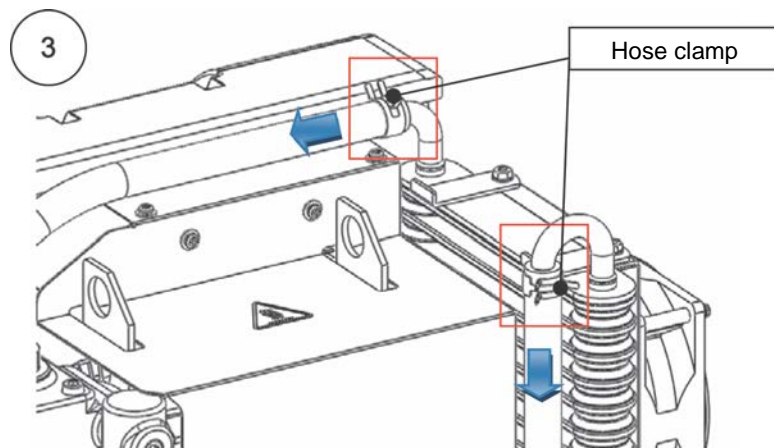

- 4) Pull off the two connected hoses. Oil may leak from the hose and oil cooler, so pull the hose off slowly while receiving the oil with a rag cloth.

<Disassembling/cleaning the oil cooler>

- 1) Remove the cross-recessed hexagon head bolts and separate the shroud from the core.

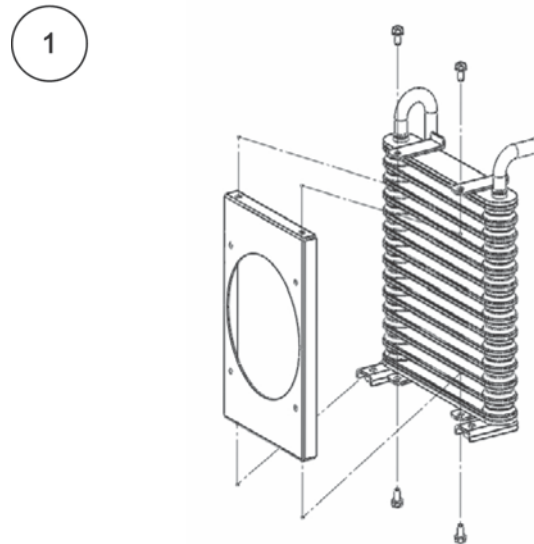

- 2) Clean off the soiling and foreign matter adhering to/accumulated on the core with a brush, then finally fully clean by blowing off remaining soiling using steam or compressed air.
* Note: There is a risk that a metal brush will damage the core, so do not use one.
- 3) If foreign matter has accumulated inside the shroud, remove the DC fan to clean.
Avoid cleaning with steam or compressed air since it will cause damage.
- 4) After cleaning, return the shroud to the core and secure with the cross-recessed hexagon head bolts (4-M5, tightening torque: 5 N·m).

6 Annexes (Work Procedures Manuals)

<Cleaning/replacing the DC fan>

- 1) Remove the connector of the DC fan harness.
- 2) Loosen the screws (4-M4, tightening torque: 1 N·m) securing the fan, and remove the fan.

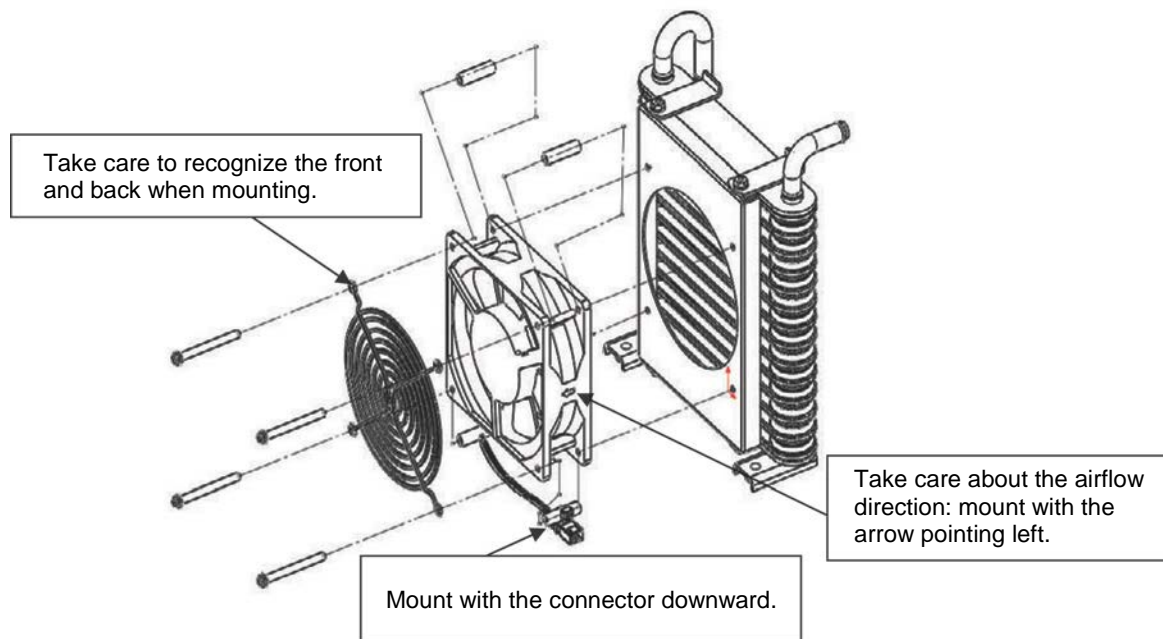

- 3) Clean the DC fan and finger guard with a rag cloth. Clean not just the fan blades and casing but also their surroundings and the clearances. Avoid cleaning with steam or compressed air since it will cause damage.

<Assembling the oil cooler>

- 1) Mount the DC fan in an oil cooler that has been cleaned, or a new oil cooler.
 - * Note: Take care about the orientation of the DC fan and finger guard during mounting.
- 2) Pass the cross-recessed screws (4-M4, tightening torque: 1 N·m) through the fan's clamping holes.
 - * Note: The DC fan has spacers in it. Be aware of this when passing the screws through.
- 3) Secure the DC fan to the shroud (4-M4, tightening torque: 1 N·m).
 - * Note: Ensure that the harness ends up under the oil cooler.

<Mounting the oil cooler>

- 1) Secure the oil cooler to the top plate of the tank with cross-recessed hexagon head bolts (2-M6, tightening torque: 5 N·m).
- 2) Pass two hoses onto the ports.

As a guide, pass them on far enough to conceal the part of the oil cooler's port section that has the coating removed.
- 3) Nip the grip part of the hose clamp with pliers to loosen the hose clamp and move it onto the oil cooler's port, then release the grip part to clamp the hose (two clamps).
- 4) Connect the DC fan harness connector.

No. PE-02465

October 18, 2016

Technical Data		Data Classification	Approved by	Checked by	Responsible Person
		C			
Date Created	June 24, 2016				
Title	ECORICH (No. 40 Design) Suction Strainer Cleaning/Replacement Procedure				
Purpose	To summarize the procedures for cleaning and replacing the suction strainer for ECORICH (No. 40 Design)				

Tools Required

- Spanner
- Torque wrench (10 N·m)
- Adjustable wrench
- Hoisting equipment

<Precautions before starting work>

- Before starting the work, stop the unit running and shut off the power supply.
- Note that oil will flow out from the tank during the work.

<Removing the tank top plate>

- 1) Remove the hexagon head bolts (4-M8, tightening torque: 10 N·m) that secure the tank top plate to the tank.

<Hoisting the tank top plate>

- 2) Check the status and condition of the hoisting equipment and the surroundings, then set the hoisting equipment in the hoisting holes to hoist the tank top plate.

Weight of the tank top plate assembly: Approx. 22 kg

- * Note: When hoisting the top plate, the tank unit may be lifted with it if the tank packing is adhering to the top plate and tank. Continuing the hoisting work in this state may lead to the tank unit being dropped, so be careful.

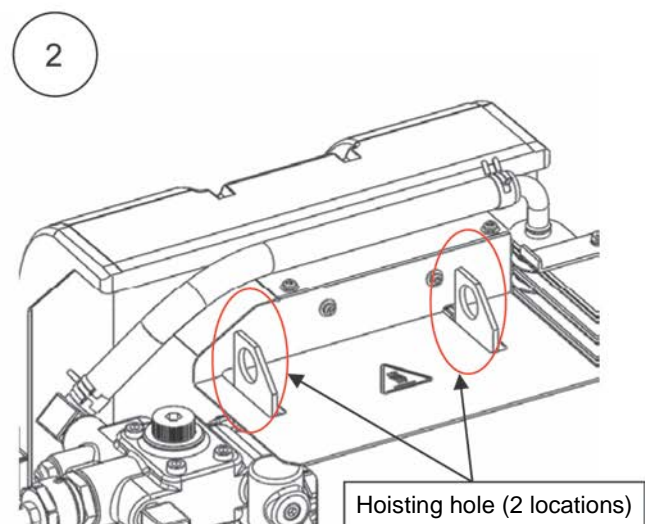
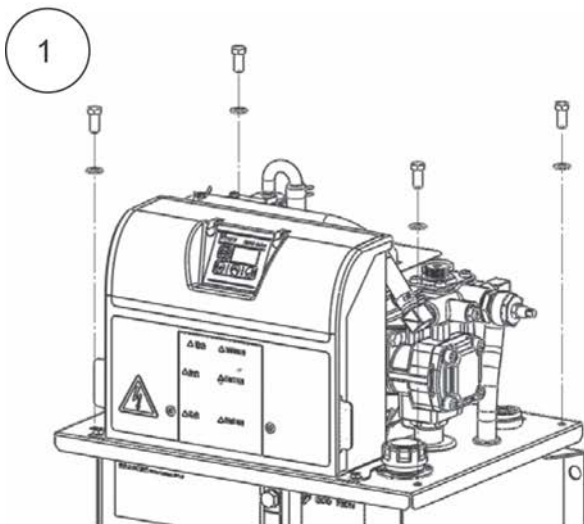

6 Annexes (Work Procedures Manuals)

- 3) Hoist the tank top plate to a position where the suction strainer is fully above the tank top. (Approx. hoisting height: 25 cm above the tank top.)
 - * Note: Oil may scatter in the surroundings when hoisting the top place, so carry out the work in a place where scattering of oil is permissible. If oil scatters, wipe it off with a rag cloth.
- 4) Turn the top plate 90° horizontally to change its orientation and rest it stably on the tank or on a stable platform.
 - * Note: Set an oil pan to receive oil.

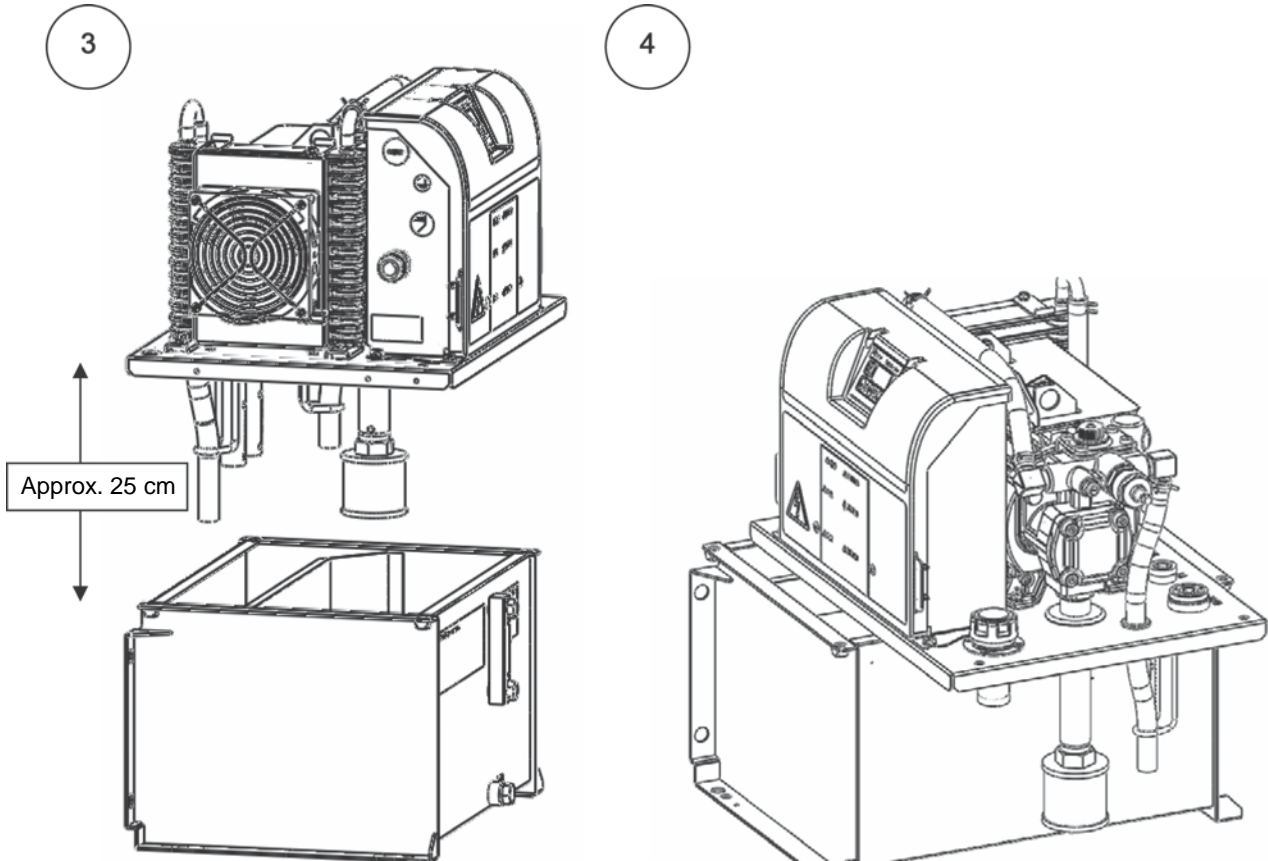

<Removing the suction strainer>

- 5) Clamp the top part of the suction pipe shown in the figure with an adjustable wrench (width across flats: 34 mm) and loosen the suction strainer by turning it clockwise using an adjustable wrench (width across flats: 32 mm) to remove it.
 - * Note: When removing the suction strainer, do it in a stable condition with the top plate properly supported.

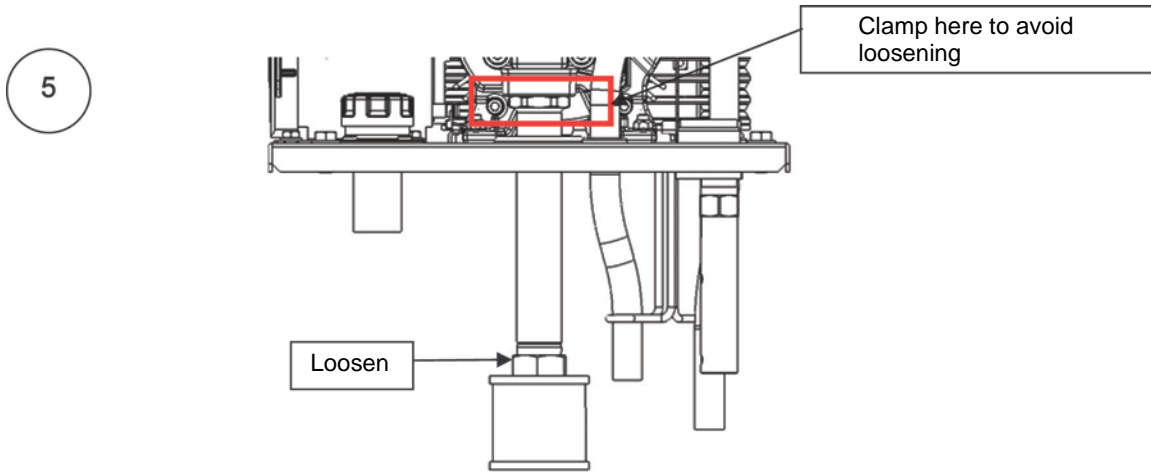

<Cleaning the suction strainer>

- 1) Air blow the suction strainer to blow off deposits.
Remove foreign matter inside the cylinder part of the strainer.
 - * Note: When using air blow, wear protective glasses to avoid getting adhering material in your eyes.

<Mounting the suction strainer>

- 1) When mounting a suction strainer after cleaning, or a new strainer, clamp the suction pipe with an adjustable wrench in the same manner as in Fig. (5).
- 2) Turn the suction strainer counterclockwise using an adjustable wrench to tighten it at the stipulated torque.
Stipulated torque for tightening suction strainer: 6 N·m

<Reassembly>

- 1) Set the hoisting equipment in the hoisting holes and hoist the top plate. (Approx. hoisting height: 25 cm)
- 2) Turn the top plate 90° to change its orientation and place it on the tank.
 - * Note: There are piping, a drainage hose and other parts at the bottom of the top plate. Therefore, lower the top plate slowly while checking visually to prevent parts coming into contact with the tank or partitions.
 - * Note: Trapped foreign matter on the tank packing may cause oil leakage. Check that there is no foreign matter trapped.
- 3) Secure the top plate to the tank with hexagon head bolts (4-M8, tightening torque: 10 N·m) fitted with a plain washer.

6 Annexes (Work Procedures Manuals)

No. PE-02466

October 18, 2016

Technical Data		Data Classification	Approved by	Checked by	Responsible Person
		C			
Date Created	June 24, 2016				
Title	ECORICH (No. 40 Design) Hydraulic Oil Change Procedure				
Purpose	To summarize the oil change procedures for ECORICH (No. 40 Design).				

<Draining hydraulic oil>

- 1) Open the drain plug (M12). Oil will gush out.
Select a working place appropriate for receiving the entire volume of hydraulic oil inside the tank in an oil receiver set below the oil drainage port.
- 2) When the hydraulic oil inside the tank has fully drained out, fit a sealing washer and drain plug and tighten the drain plug at the stipulated torque.
(Be sure to fit a sealing washer without fail.)
Drain plug tightening torque: 42.7 N·m

<Replenishing hydraulic oil>

- 1) Remove the cap of the filler port cum air breather by turning it counterclockwise, then pour clean hydraulic oil (within NAS class 10) into the tank using e.g. an oil jug. (Check that the drain plug is tightened to the stipulated torque.)
- 2) The volume of oil should be sufficient to bring the float (black ball) to between the red line and yellow line.
* Note: Replenish oil with a filter inserted to avoid entry of foreign matter into the tank.
- 3) After replenishing oil, fully tighten the cap of the filler port cum air breather by turning it clockwise.

No. PE-02468

October 18, 2016

Technical Data		Data Classification	Approved by	Checked by	Responsible Person
			C		
Date Created	June 24, 2016				
Title	ECORICH (No. 40 Design) DC Fan Motor Fuse Replacement Procedure				
Purpose	To summarize the motor fuse replacement procedures for ECORICH (No. 40 Design).				

<Removing the controller exterior cover>

- 1) Loosen the controller exterior cover's fixing screws (4-M4, tightening torque: 1 N·m) and remove the exterior cover.

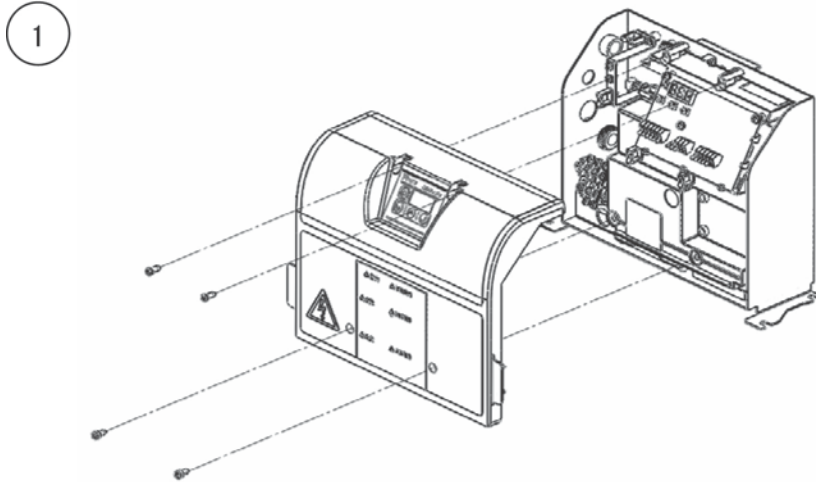

<Replacing the fuse>

- 2) Opening the controller exposes a fuse at the upper right of the interface PCB. Replace the fuse after checking that there is no damage or contamination on the terminals.

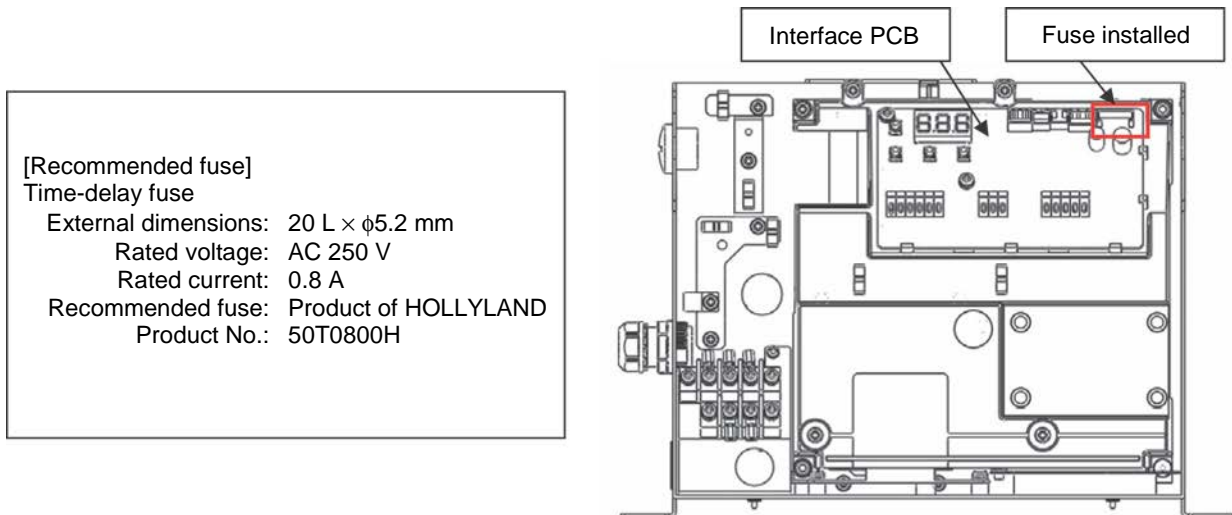

<Mounting the controller cover>

- 3) Set the controller exterior cover on the controller unit and tighten the fixing screws (4-M4, tightening torque: 1 N·m).

6 Annexes (Work Procedures Manuals)

No. PE-02490

October 18, 2016

Technical Data		Data Classification	Approved by	Checked by	Responsible Person
			C		
Date Created	June 24, 2016				
Title	ECORICH (No. 40 Design) Motor Coil/Power Device Resistance Measurement Procedure				
Purpose	To summarize the resistance measurement procedures of the motor coil and power device for ECORICH (No. 40 Design).				

<Resistance measurement procedure for the motor coil>

<Removing the controller exterior cover>

- 1) Loosen the exterior cover's fixing screws (4-M4, tightening torque: 1 N·m) and remove the exterior cover.

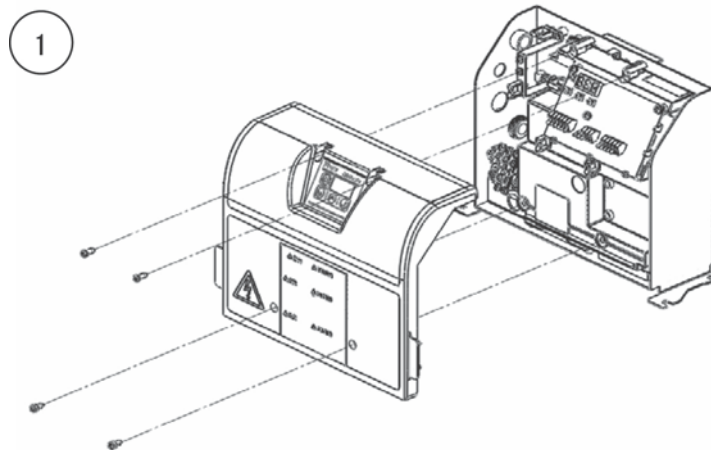

<Disconnecting motor terminals>

- 2) Opening the controller exposes the motor harness connected to the power PCB.
Nip the housing (white) at the connection position and pull it in the vertical direction to the PCB to remove it.

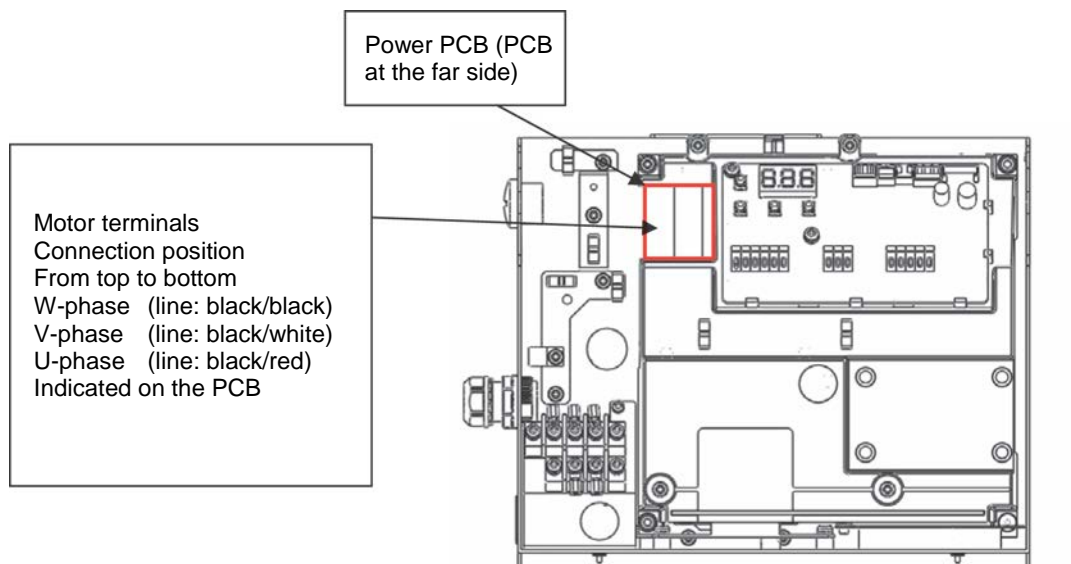

<Measurement and judgment>

- 3) Measure the resistance between the U-V terminals, V-W terminals and W-U terminals using a multimeter. It is normal if the resistances are almost same in three measurements.
If there is continuity between the ground and any of the motor wires, it indicates a ground fault and is abnormal.

<Resistance measurement procedure for the power device>

- 4) The photo shows the motor terminal connections.
The locations to be touched to measure resistances are indicated.

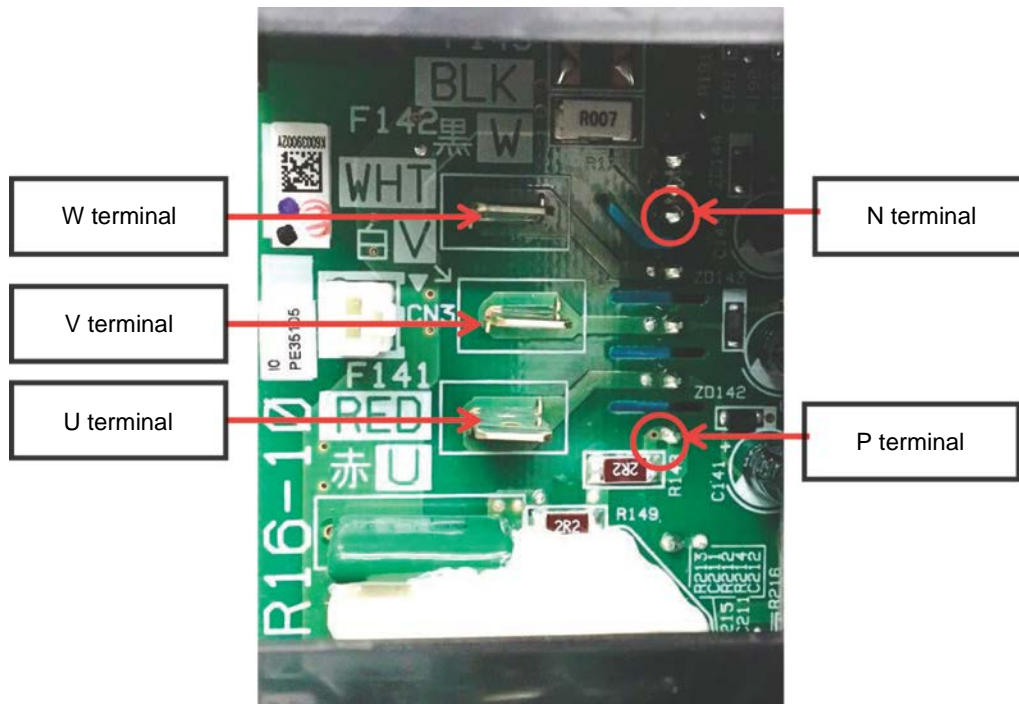

Resistance measurement of the power module

- Between U(-) and P(+), U(+) and N(-)
- Between V(-) and P(+), V(+) and N(-)
- Between V(-) and P(+), W(+) and N(-)

Measure the above resistances and if the value is less than 10Ω, the device is judged as abnormal.

* The indications in parentheses above show the polarity for measurement.

(+) Red multimeter probe (-) Black multimeter probe

<Mounting the controller cover>

- 5) Set the controller exterior cover on the controller unit and tighten the fixing screws (4-M4, tightening torque: 1 N·m).

6 Annexes (Work Procedures Manuals)

No. PE-02491

October 18, 2016

Technical Data		Data Classification	Approved by	Checked by	Responsible Person
		C			
Date Created	June 24, 2016				
Title	ECORICH (No. 40 Design) Input Power/Ground Fault Check Procedure				
Purpose	To summarize the procedures for checking the input power supply and ground fault for ECORICH (No. 40 Design).				

<Measuring the input power supply voltage>

<Removing the controller exterior cover>

- 1) Loosen the exterior cover's fixing screws (4-M4, tightening torque: 1 N·m) and remove the exterior cover.

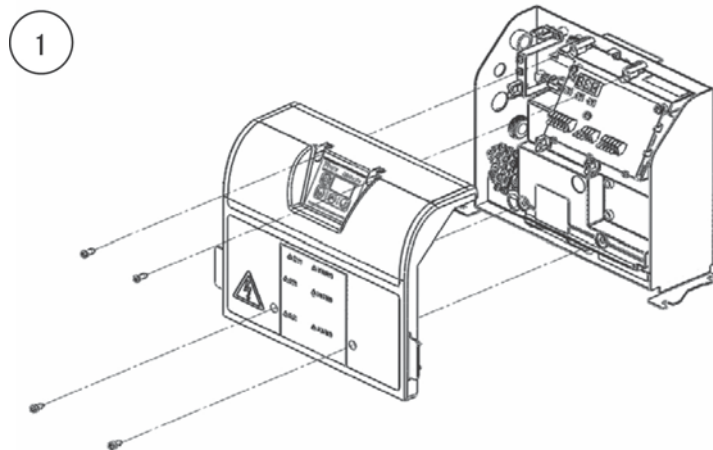

<Voltage measurement>

- 2) Turn the power supply on and check the power supply voltage at the power supply terminal block located at the bottom left side of the controller using a multimeter.
 - If the voltage between the L1-L2 phases, L1-L3 phases and L2-L3 phases are within the rated range, it is judged normal.Rated value:
 - 200 V \pm 10% 50/60 Hz
 - 220 V \pm 10% 60 Hz

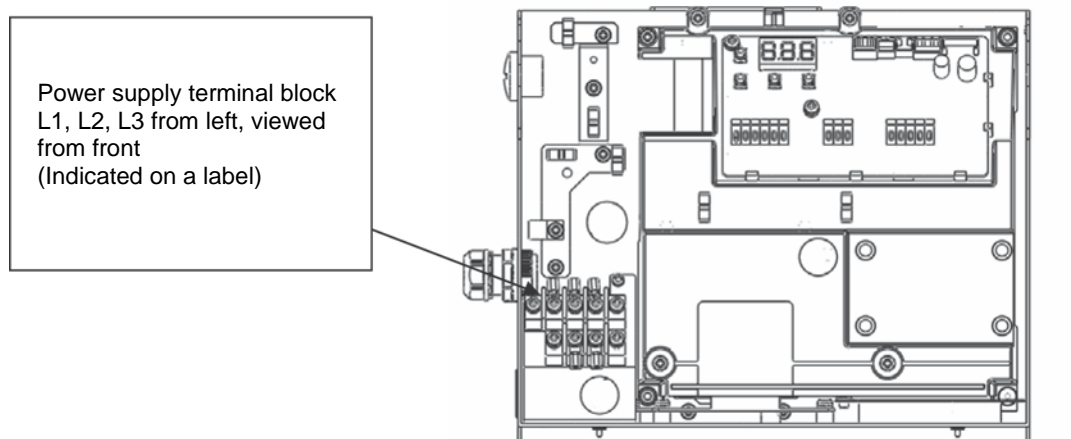

Power supply terminal block
L1, L2, L3 from left, viewed
from front
(Indicated on a label)

<Checking for ground fault of the power supply>

- 1) Turn the unit power off.
- 2) Remove the exterior cover of the controller.
- 3) Connect the ground probe of an insulation tester to the controller housing.
- 4) Measure the insulation resistance by touching the terminal of each phase with the positive probe.

Between L1 and ground, L2 and ground, and L3 and ground

It is judged normal if the resistance is 100 M Ω or greater.

If the resistance is less than 100 M Ω , disconnect the power cable and check the insulation resistance of the unit itself.

- If the resistance is 100 M Ω or greater:
→ The unit is normal, the power supply may be faulty
- If the resistance is less than 100 M Ω :
→ The unit is faulty

<Mounting the controller exterior cover>

- 5) Set the controller exterior cover on the controller unit and tighten the fixing screws (4-M4, tightening torque: 1 N·m).

6 Annexes (Work Procedures Manuals)

No. PE-02499

October 18, 2016

Technical Data		Data Classification	Approved by	Checked by	Responsible Person
		C			
Date Created	June 24, 2016				
Title	ECORICH (No. 40 Design) Controller PCB Replacement Procedure				
Purpose	To summarize the replacement procedures for the PCBs inside the controller for ECORICH (No. 40 Design).				

<Removing the controller cover>

- 1) Loosen the exterior cover's fixing screws (4-M4, tightening torque: 1 N·m) and remove the exterior cover.

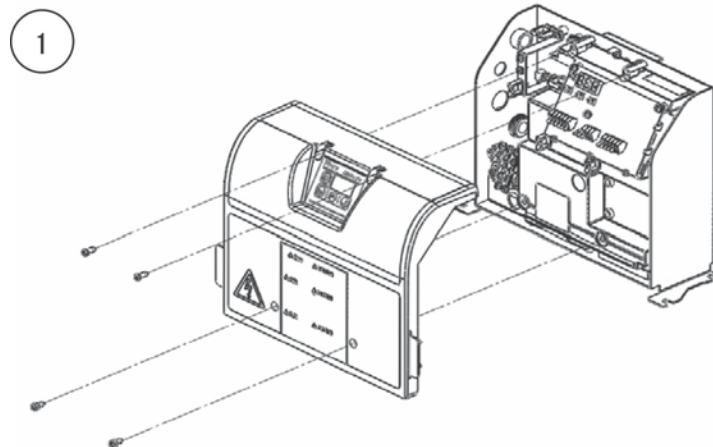

<Replacing the interface PCB>

- 1) Remove the fixing screws (2-M4, tightening torque: 1 N·m) of the interface PCB and slide the PCB in the arrowed directions to remove it.
 - * Note: Take care not to drop the screwdriver, etc. while removing the screws. Otherwise the PCB may be damaged.
- 2) Slide the new PCB in the arrowed directions to clamp it with the catches and tighten the interface PCB's fixing screws (2-M4, tightening torque: 1 N·m).

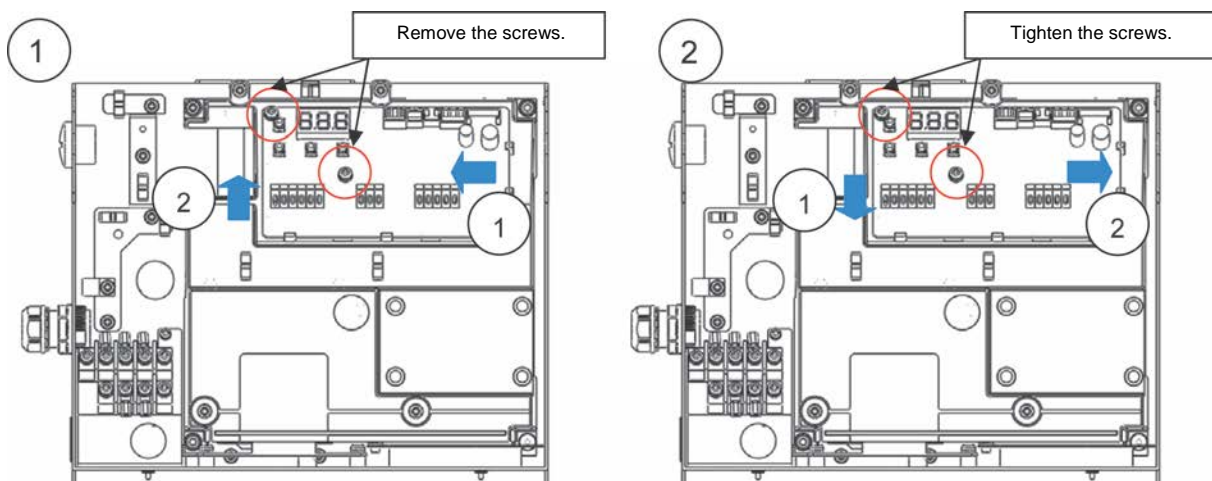

- 3) Reconnect the connectors (CN6, 7, 11) and wiring that were connected to the PCB before removing it, to the new PCB.

<Replacing the power PCB: Removal>

- 1) Disconnect the harness connectors (CN5, 6, 7 and 11) connected to the interface PCB.
- 2) Loosen the internal cover's fixing screws (4-M4, tightening torque: 1 N·m) and remove the internal cover.
- 3) There is no DCL with EHU1404/EHU2504.
Disconnect the harnesses connected to F21 and F22 of the power PCB.
Disconnect the harness connected to CN903 also.
- 4) A DCL is incorporated with EHU3007/EHU2507.
Disconnect the harnesses connected to F21 and F22 of the power PCB.
Disconnect the harness connected to CN903 also.
- 5) With EHU3007/EHU2507, loosen the DCL's fixing screws (4-M4, tightening torque: 1 N·m) and remove the DCL.

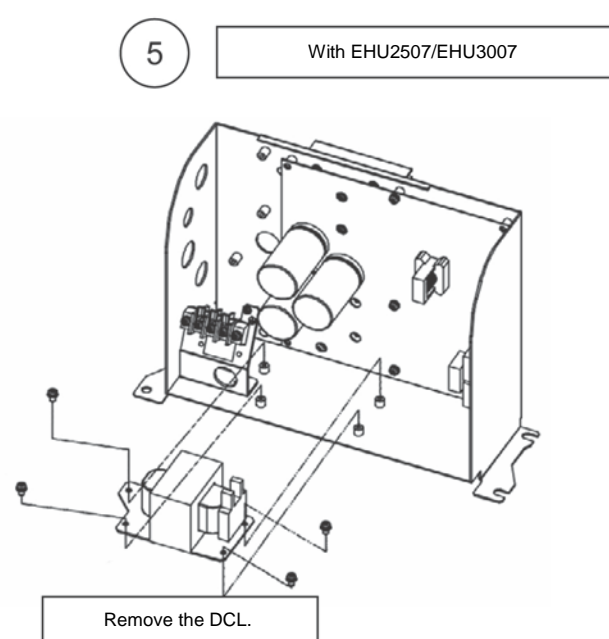
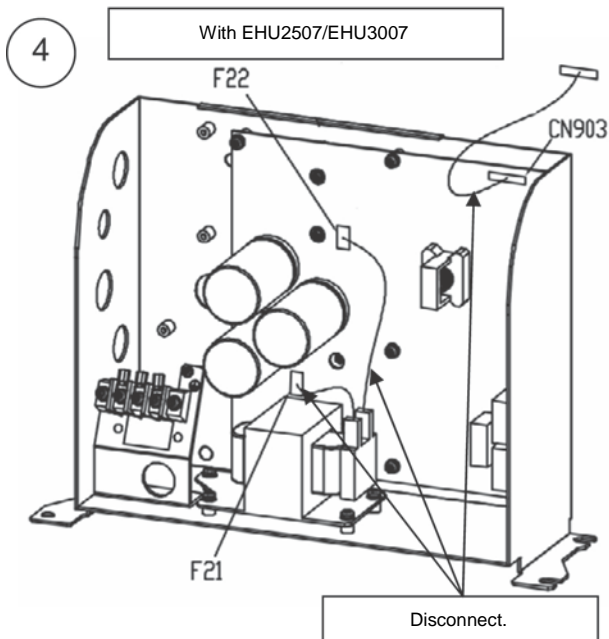
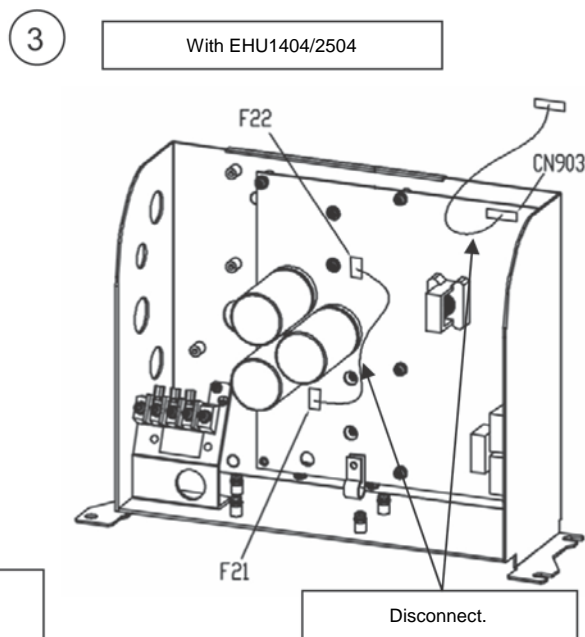
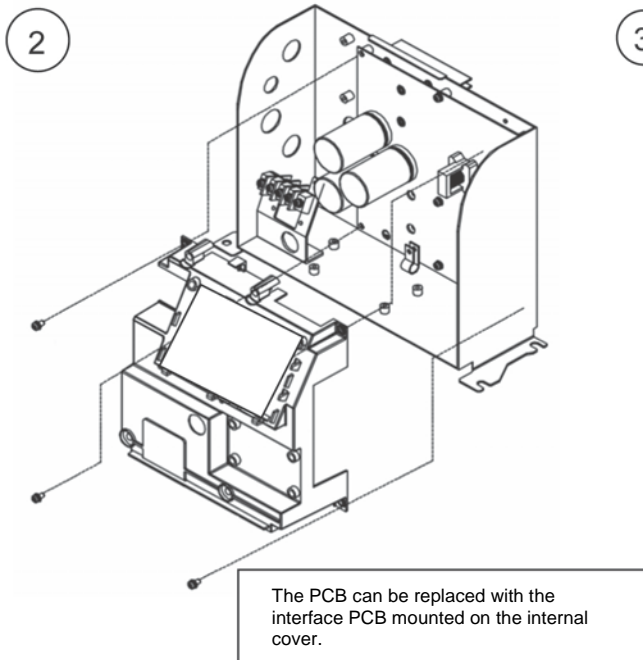

6 Annexes (Work Procedures Manuals)

- 6) Disconnect the connectors connected to F1, F2 and F3 on the PCB.
Remove the KS clamps to detach the power supply relay harness.

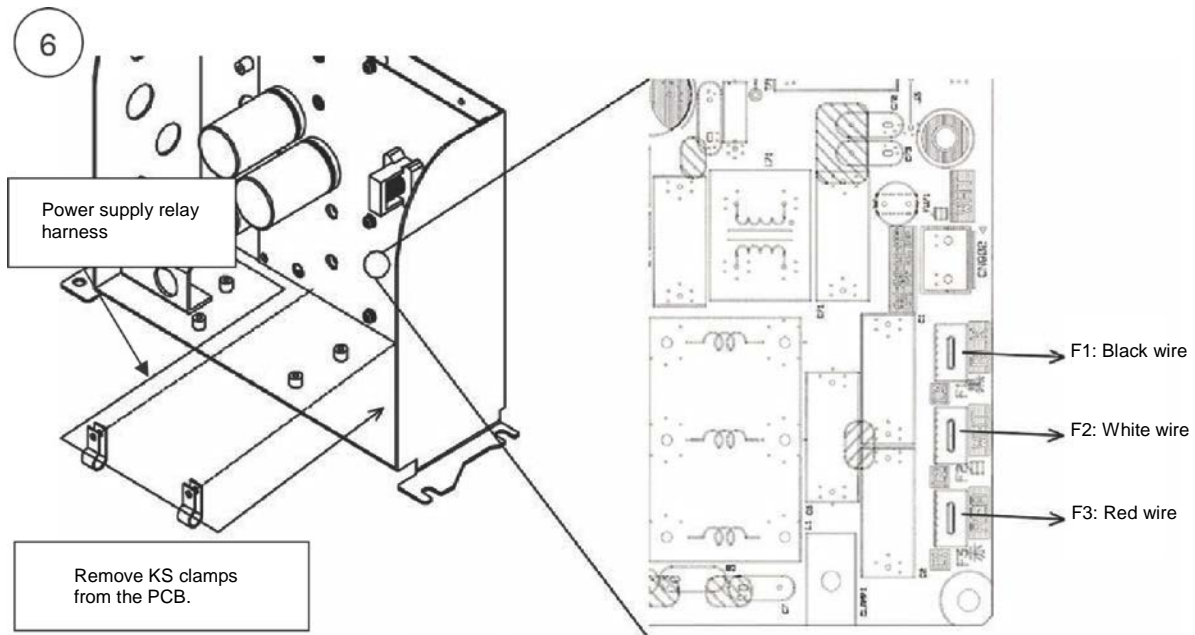

- 7) Remove the power PCB's fixing screws (5-M4, tightening torque: 1 N·m).
8) Loosen the fixing screws (4-M3, tightening torque: 0.63 N·m) of the power device and diode bridge, and remove the PCB.
- * Note: When removing the PCB, the heat dissipation sheet may adhere to the PCB and come off the heatsink.
The heat radiation sheet will be reused so remove it from the PCB.

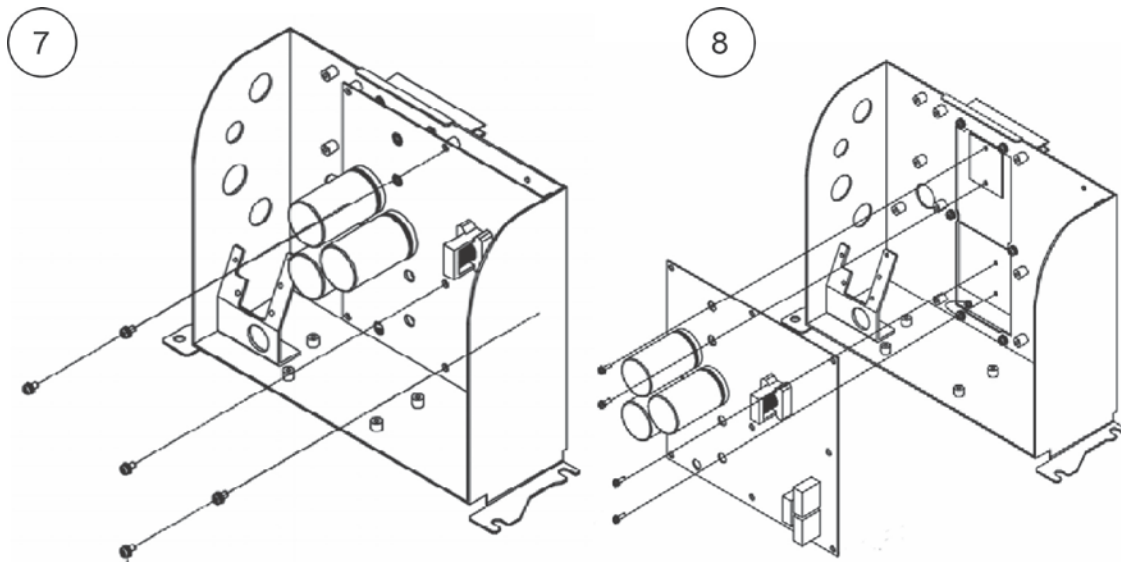

<Replacing the power PCB: Mounting>

- 1) Prepare a new power PCB.

(Difference in appearance: The number of electrolytic capacitors in the main circuit is 1 for EHU1404/EHU2504, and 2 for EHU2507/EHU3007)

Set the power PCB on the housing.

- * Note: Check that the heat radiation sheet is attached at the appropriate position on the heatsink. Also check that it does not cover the steps and screw holes.

Provisionally secure the power device and diode bridge with the fixing screws (4-M3).

The screws are to be fully tightened after mounting the power PCB.

- 2) Check the positions of the mounting holes in the power PCB and secure it on the base frame with screws (5-M4, tightening torque: 1 N·m).

Fully tighten the four fixing screws of the power device and diode bridge to the stipulated tightening torque of 0.63 N·m.

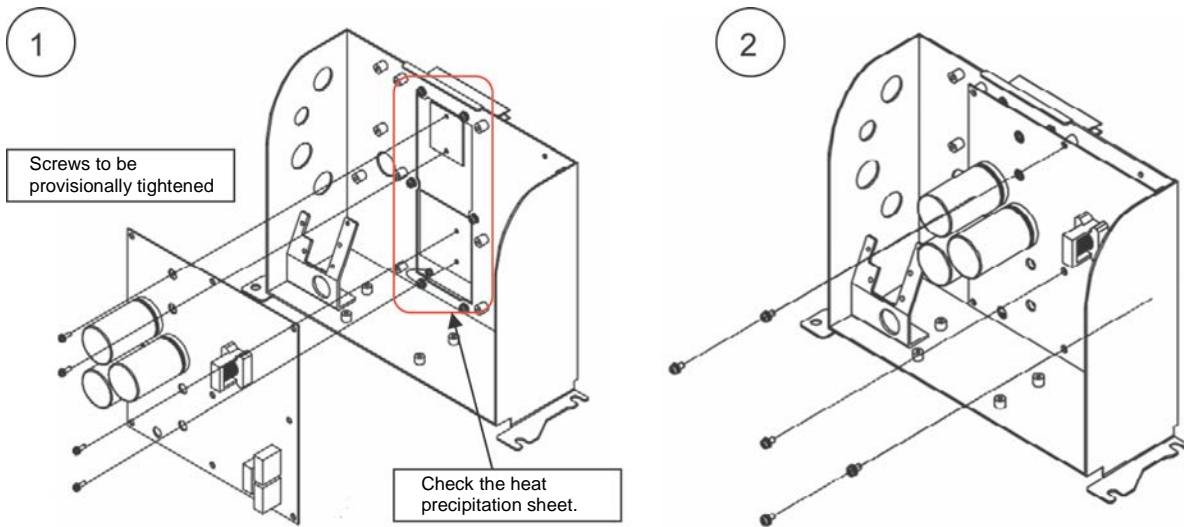

- 3) Connect the power supply relay harness to the tab terminals (F1, F2 and F3) on the PCB. Secure the power supply relay harness with KS clamps using the mounting holes in the PCB at two places.

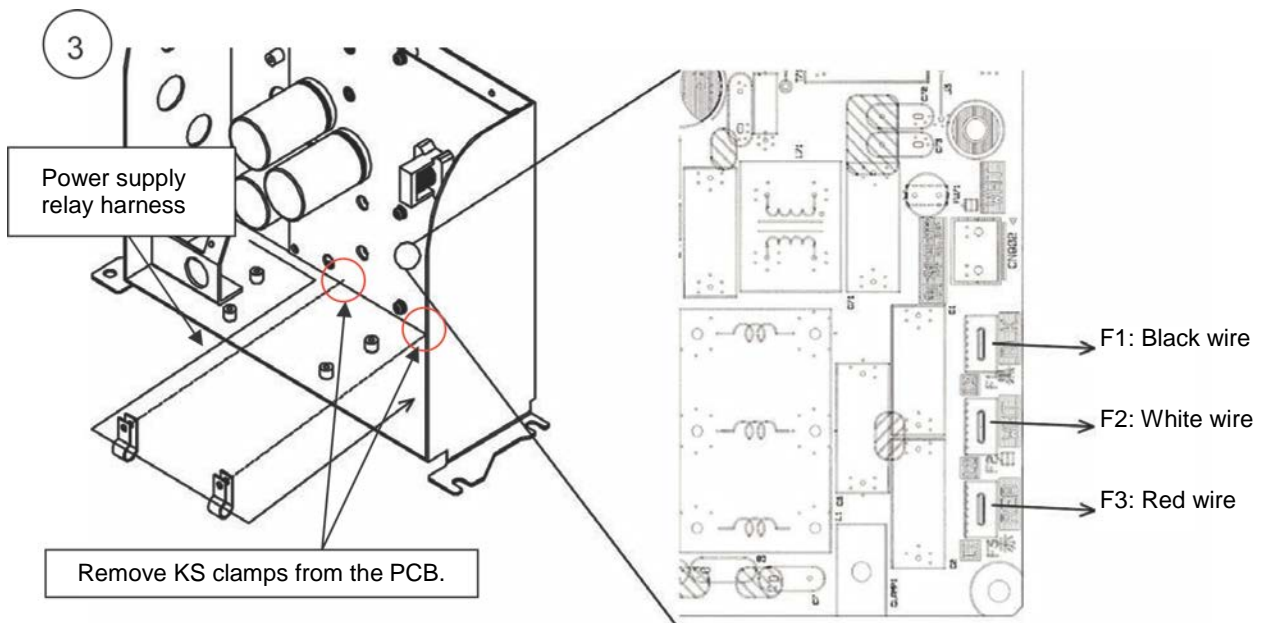

6 Annexes (Work Procedures Manuals)

4) For EHU1404/2504

Connect the DCL shorting harness to F21 and F22 on the power PCB.

In addition, connect the power/interface communication harness to CN903.

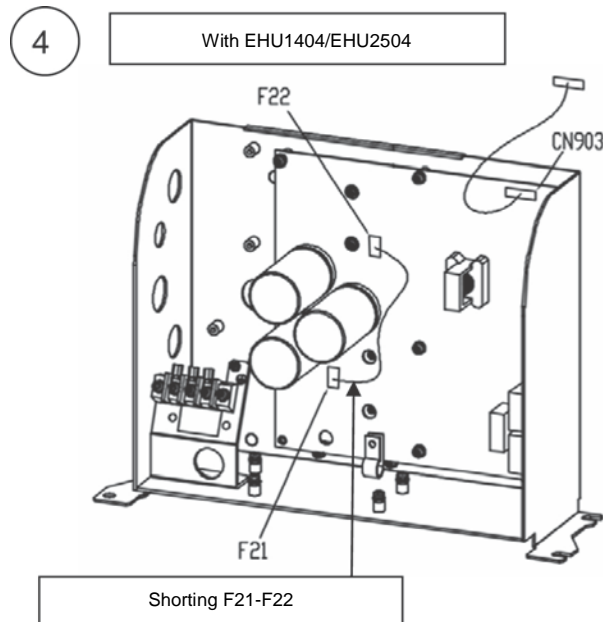

5) For EHU2507/EHU3007

Set the DCL on the base frame and secure with fixing screws (4-M4, tightening torque: 1 N·m).

6) Connect the DCL to F21 and F22 on the power PCB using the DCL harness.

(* Can be connected to either terminal)

In addition, connect the power/interface communication harness to CN903.

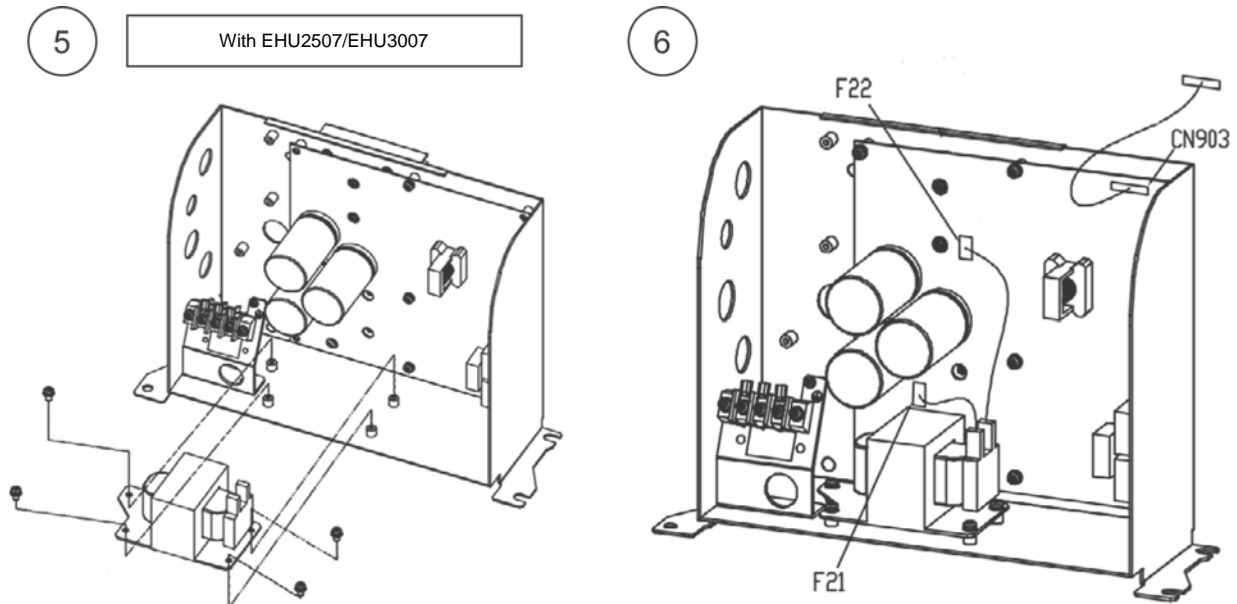

- 7) Set the internal cover and secure it with the fixing screws (4-M4, tightening torque: 1 N·m)

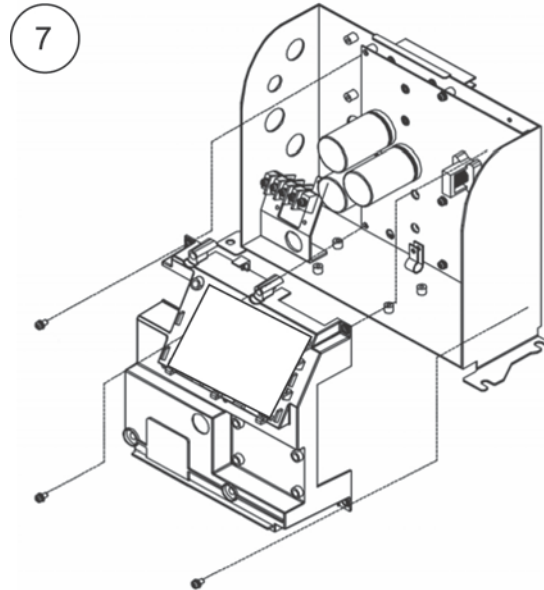

- 8) Connect the connectors (CN5, 6, 7 and 11) of the harness that is connected to the interface PCB.

* Note: Route the harnesses through the upper part of the internal cover by referring to the figure below.

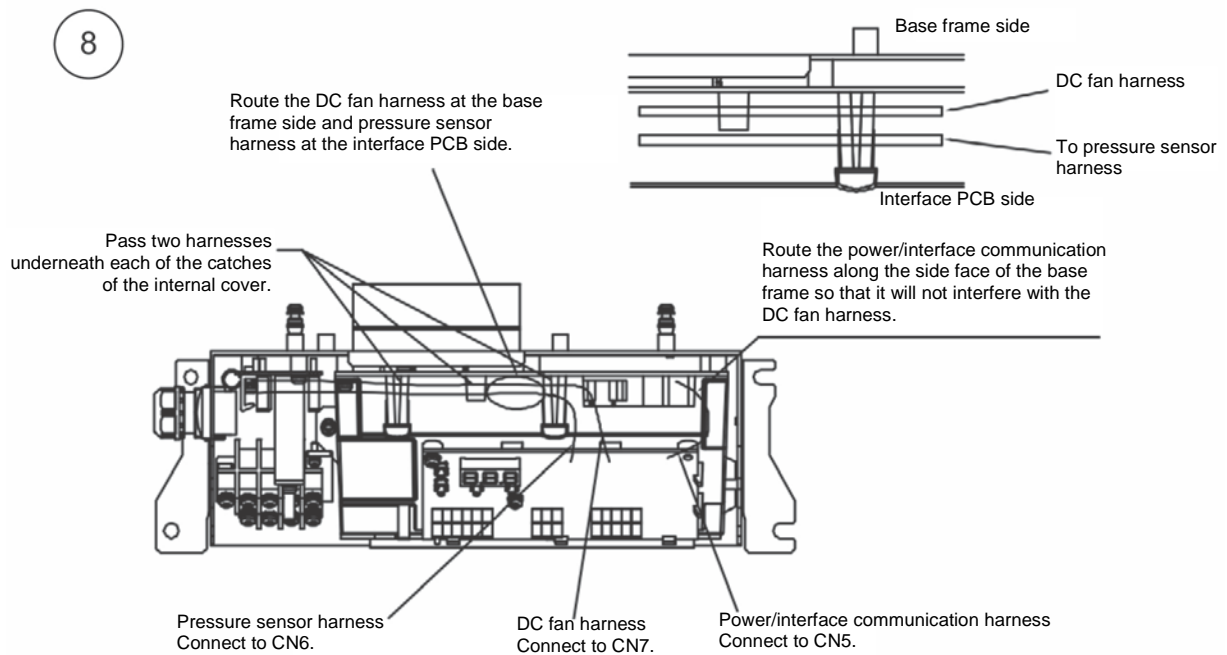

6 Annexes (Work Procedures Manuals)

No. PE-02505

October 18, 2016

Technical Data		Data Classification	Approved by	Checked by	Responsible Person
		C			
Date Created	June 24, 2016				
Title	ECORICH (No. 40 Design) Harness Connection Check Procedure				
Purpose	To summarize the procedures for checking the connection of harnesses for ECORICH (No. 40 Design)				

<Harness check items (common)>

- Check that there is no damage, breakage or kink on the covering of harnesses.
- Check that the connectors are secured to the housing with latches and not lifted/disconnected.
- Check that there is no crack or chipping on the housings.

<Interface PCB (common to all models)>

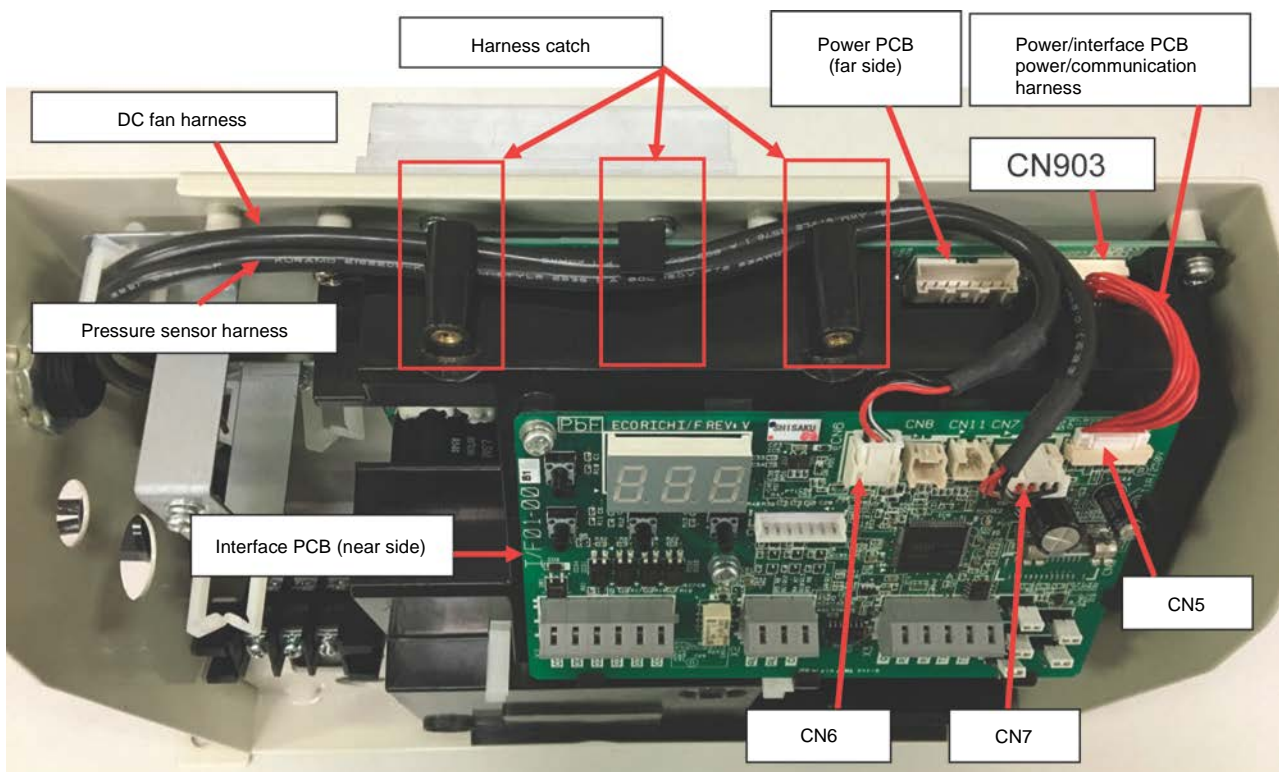

<Power/interface PCB power/communication harness>

- 1) Connect the power PCB (CN903) and interface PCB (CN5).
- 2) The connectors at both ends are the same and can be connected to either PCB.

<DC fan harness>

- 1) Connect to CN7 on the interface PCB.
- 2) Route the harness through the far side by passing it through three catches of the internal cover.

<Pressure sensor harness>

- 1) Connect to CN6 on the interface PCB.
- 2) Route the harness through the near side by passing it through three catches of the internal cover.

<Power section>

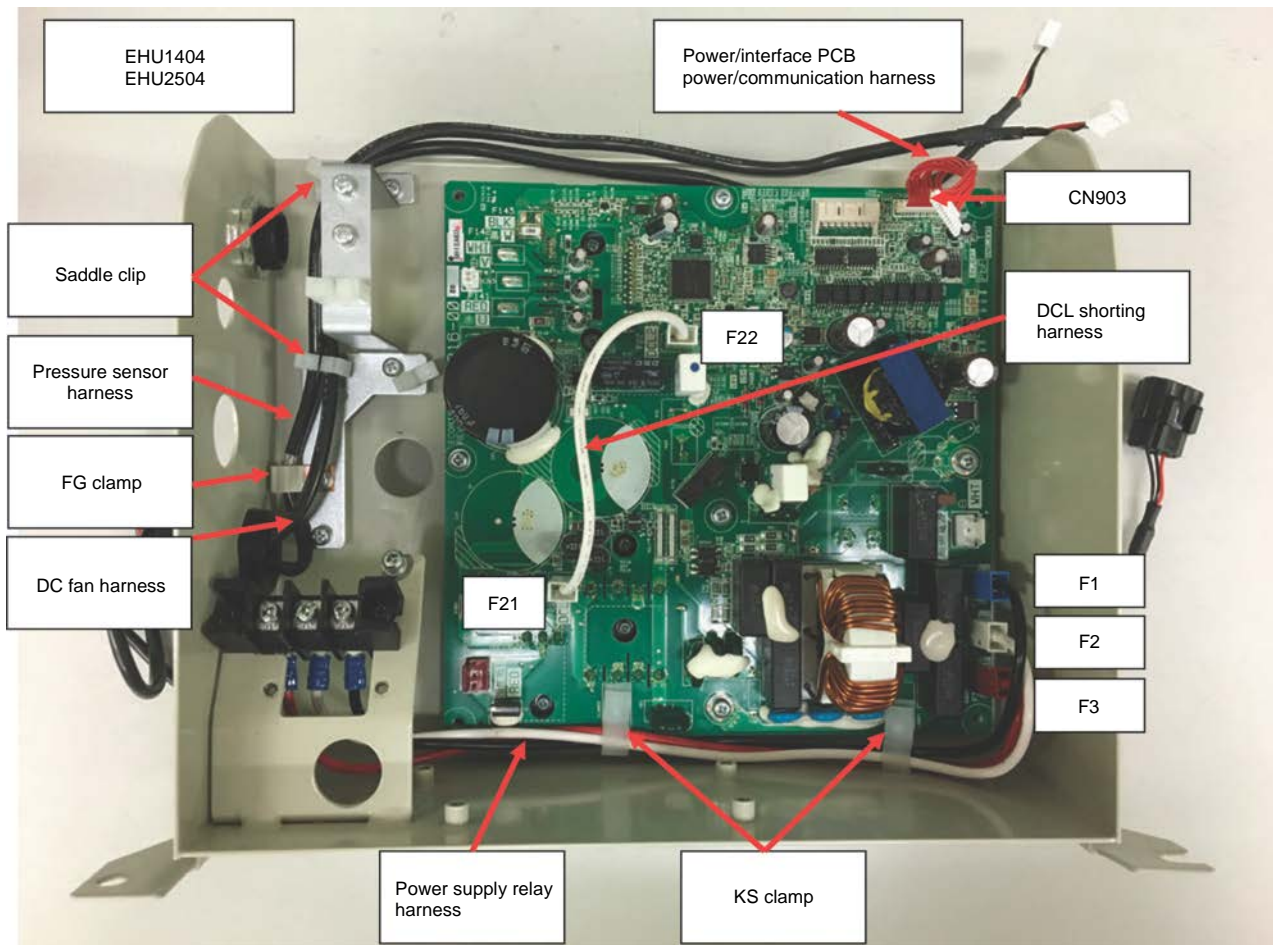

<Pressure sensor harness>

- 1) Secure the sheath with an FG clamp.
- 2) Pass the harness through two saddle clips.

<DC fan harness>

- 1) Pass the harness through two saddle clips.

<Power supply relay harness (three wires)>

- 1) Check that the wires are connected from the terminal block to the tab terminals (F1-F3) on the PCB.
- 2) Secure the wires with KS clamps.
- 3) Wires must be connected to the tab terminals on the PCB according to the wire colors indicated on the PCB.

<DCL short circuit harness>

- 1) Short F21-F22 with the short circuit harness. (1.5 kW models are not equipped with DCL.)

6 Annexes (Work Procedures Manuals)

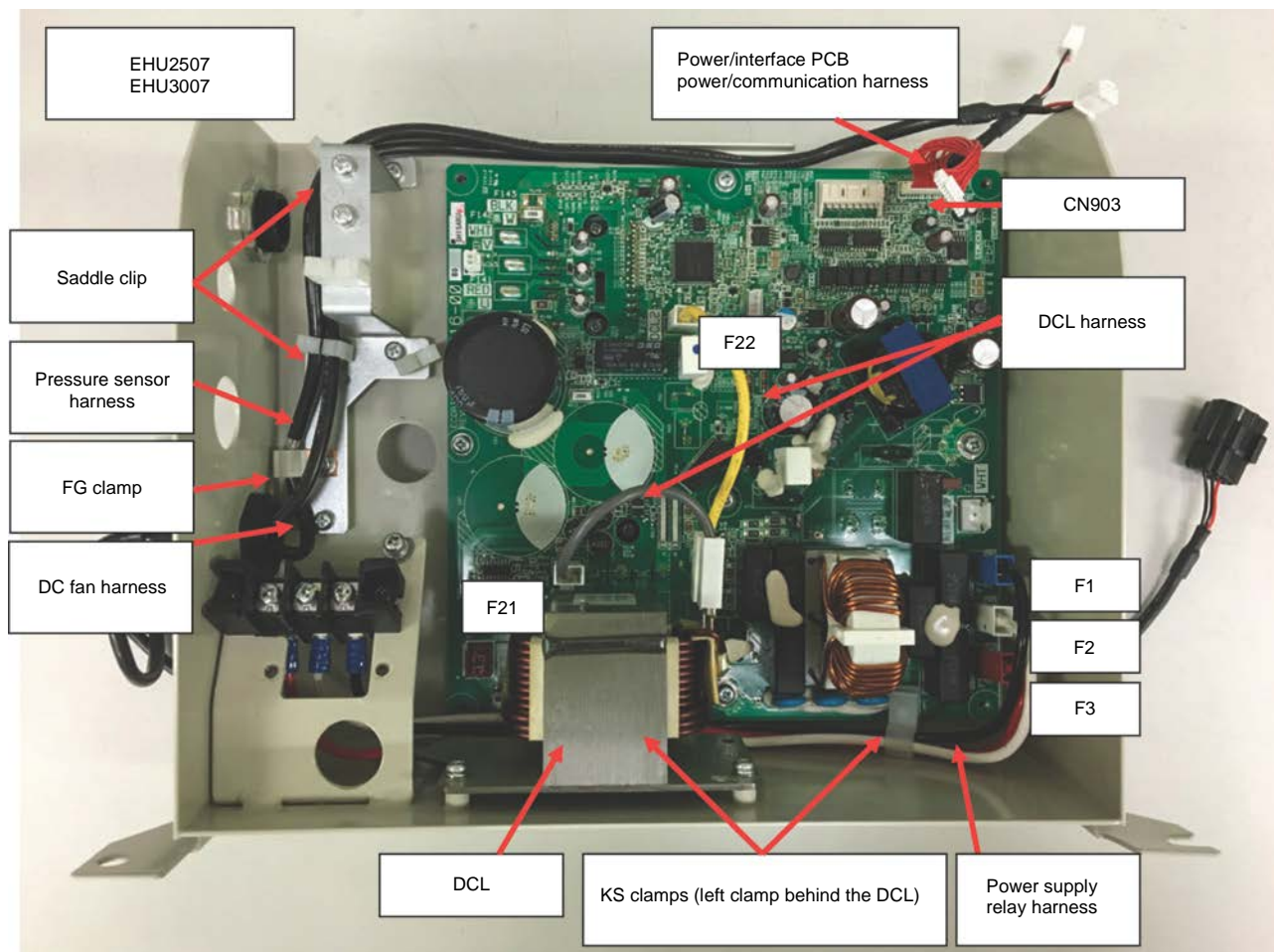

<Pressure sensor harness>

- 1) Secure the sheath with an FG clamp.
- 2) Pass the harness through two saddle clips.

<DC fan harness>

- 1) Pass the harness through two saddle clips.

<Power supply relay harness (three wires)>

- 1) Check that the wires are connected from the terminal block to the tab terminals (F1-F3) on the PCB.
- 2) Secure the wires with KS clamps.
- 3) Wires must be connected to the tab terminals on the PCB according to the wire colors indicated on the PCB.

<DCL harness>

- 1) Connect F21 and F22 to the DCL with the harness. (2.8 kW models are equipped with a DCL.)
(Reverse of the connection in the photo also possible)

<Motor connection section>

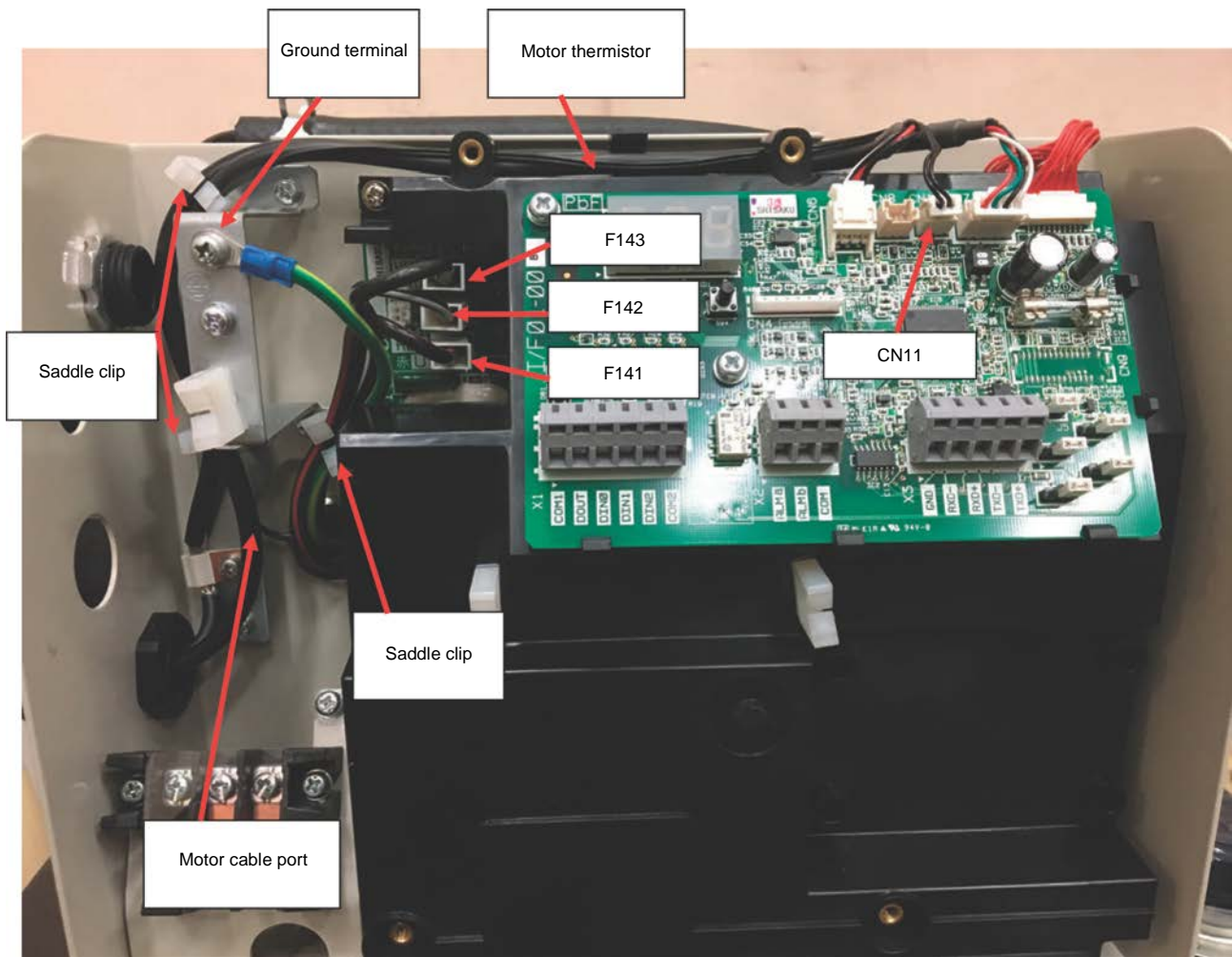

<Motor power cable (Three wires)>

- 1) Check that the wires are connected to the tab terminals (F141-F143) on the PCB.
 - * The wire colors and phases are printed on the PCB. The wires must be connected carefully according to the indication. Incorrect connection causes reverse motor rotation, disabling normal operation of the unit.
- 2) Secure the wires with a cable clamp.

<Ground wire>

- 1) Connect the ground wire leading from the motor cable port to the upper threaded hole.
- 2) Lead the wire from the right side with respect to the threaded hole.
- 3) Clamp the wire with an M4 screw at 1 N·m.
- 4) Secure the wire using the saddle clip together with the motor power wires.

<Motor thermistor>

- 1) Pass the harness through tow saddle clips.
- 2) Route the harness through three catches of the internal cover.
- 3) Connect to CN11 on the interface PCB.

6 Annexes (Work Procedures Manuals)

No. PE-02506

October 18, 2016

Technical Data		Data Classification	Approved by	Checked by	Responsible Person
		C			
Date Created	June 24, 2016				
Title	ECORICH (No. 40 Design) Variable Relief Pressure/Minimum Rotation Speed Adjustment Procedure				
Purpose	To summarize the procedures for adjusting the variable relief pressure for ECORICH (No. 40 Design)				

<Workflow>

1. Checking the minimum rotation speed during holding pressure
2. Mounting the fixed throttle
3. Removing the fixed throttle
4. Setting the relief valve setting to the maximum
5. Changing the holding pressure setting
6. Adjusting the rotation speed during holding pressure
7. Adjusting the relief valve pressure setting

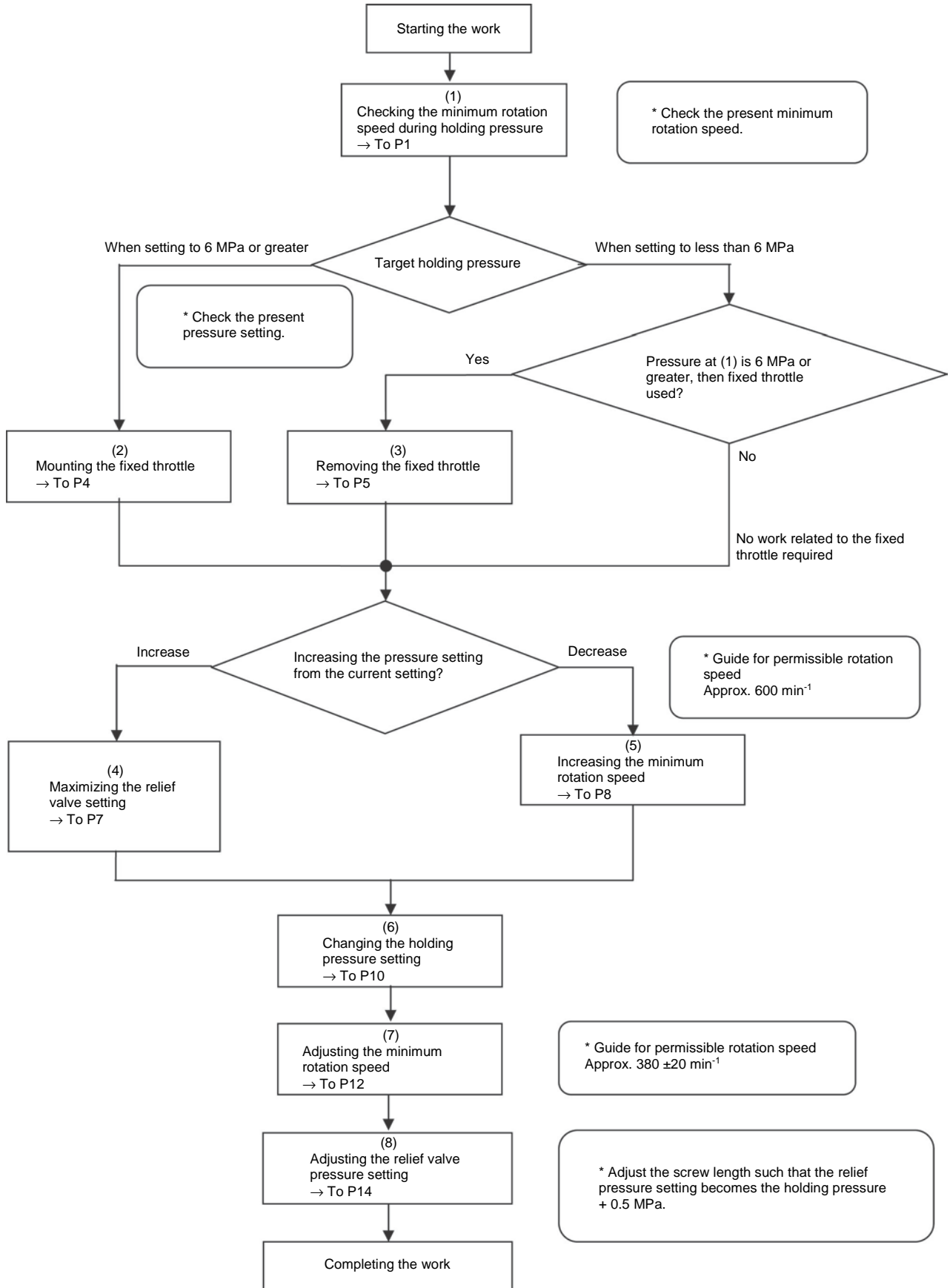

[Reference] Guide for relation between PC pressure and pressure adjustment screw length

1.2 Workflow



6 Annexes (Work Procedures Manuals)

1. Checking the minimum rotation speed

- 1) Block port P with a plug.
- 2) Place the unit on a level site and replenish hydraulic oil.
- 3) Mount safety devices such as the no-fuse breaker and carry out the wiring.
- 4) Upon powering on, the set pressure is displayed on the operation panel of the ECORICH.
- 5) Press the  key to select the monitor mode.
- 6) Select the  or  key to change the display indication to "n05".
- 7) The current rotation speed is displayed. (Rotation speed min^{-1} = Display indication \times 10)

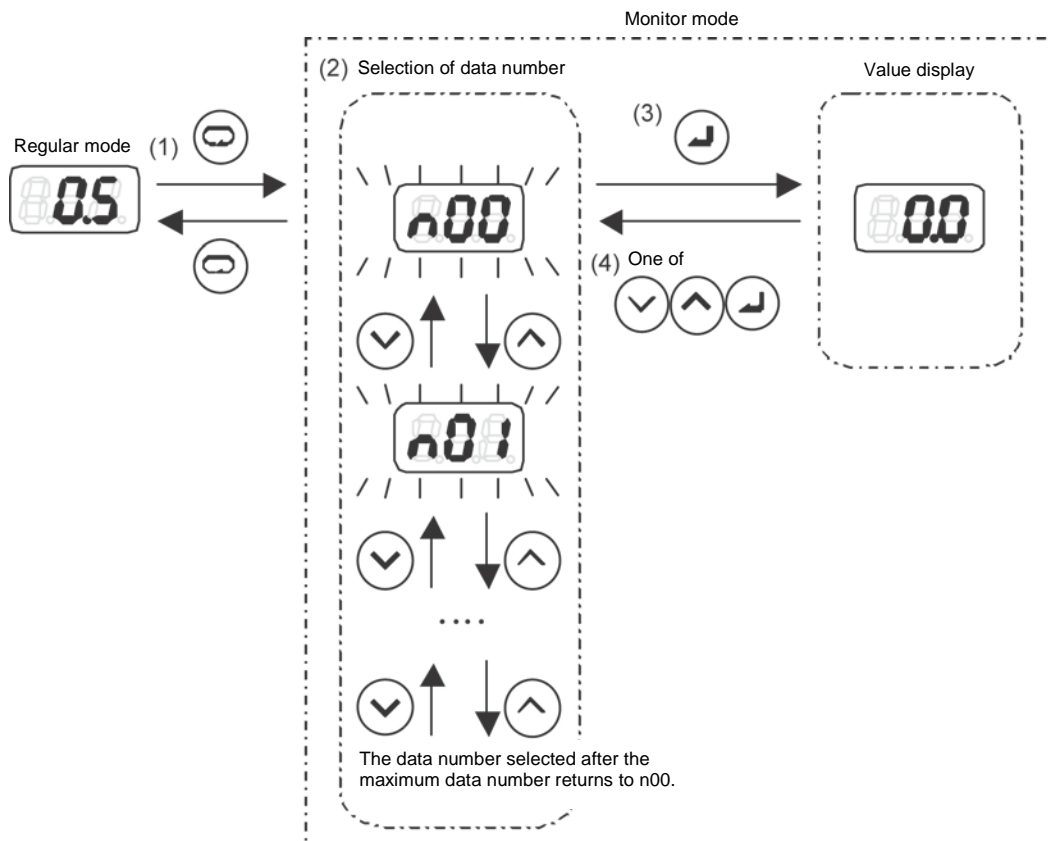

2. Mounting the fixed throttle (when the set pressure is 6 MPa or greater)

- * Note: Carry out the work with the power turned off.
- * Note: Release the pressure inside the hydraulic circuit and check that there is no residual pressure.

- 1) Turn the power off and check that the motor has stopped.
- 2) Release the pressure inside the hydraulic circuit and check that there is no residual pressure.
- 3) Remove the hexagon socket head T plug (Rc 1/4).
 - * Note: Oil may leak during the work, so wipe it off with a rag cloth.
- 4) Mount the fixed throttle (NPTF1/16 × $\phi 0.8$) without wrapping sealing tape.
Tightening torque $6.9 \pm 0.5 \text{ N}\cdot\text{m}$
- 5) Wrap sealing tape around the hexagon socket head T plug (Rc 1/4) and fit it.
Tightening torque $26.0 \pm 1.0 \text{ N}\cdot\text{m}$

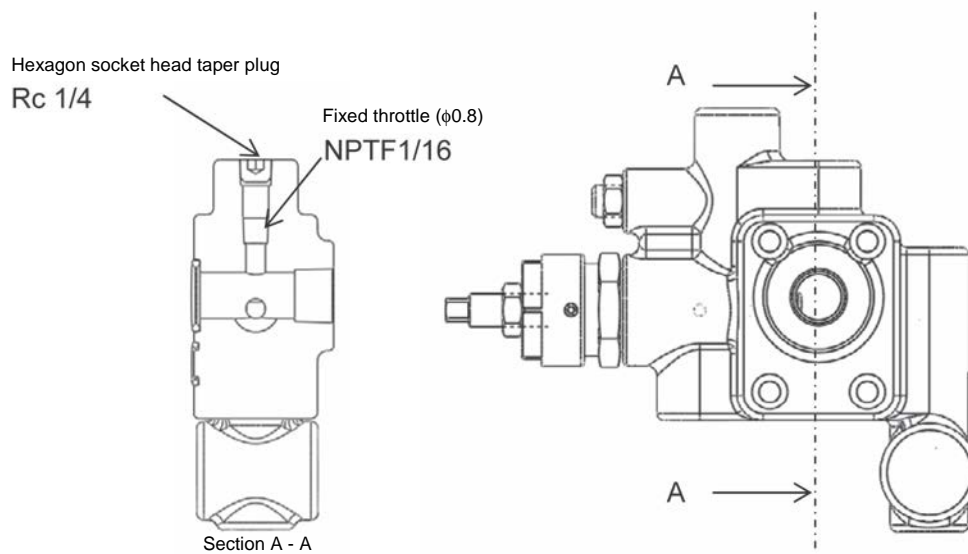
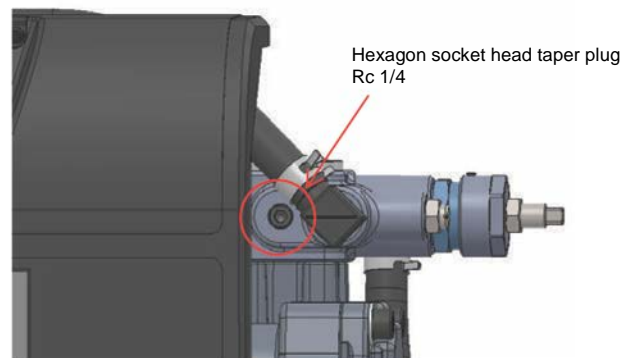

6 Annexes (Work Procedures Manuals)

3. Removing the fixed throttle

(When the fixed throttle is mounted, the pressure is set at less than 6 MPa and the pressure at the minimum rotation speed is 6 MPa or greater)

- * Note: Carry out the work with the power turned off.
- * Note: Release the pressure inside the hydraulic circuit and check that there is no residual pressure.

- 1) Turn the power off and check that the motor has stopped.
- 2) Release the pressure inside the hydraulic circuit and check that there is no residual pressure.
- 3) Remove the hexagon socket head T plug (Rc 1/4).
 - * Note: Oil may leak during the work, so wipe it with a rag cloth.
- 4) Remove the fixed throttle (NPTF1/16 × $\phi 0.8$).
- 5) Wrap sealing tape around the hexagon socket head T plug (Rc 1/4) and fit it.

Tightening torque $26.0 \pm 1.0 \text{ N}\cdot\text{m}$

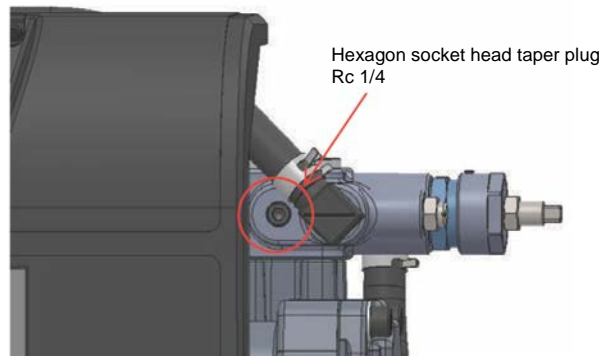

Hexagon socket head taper plug
Rc 1/4

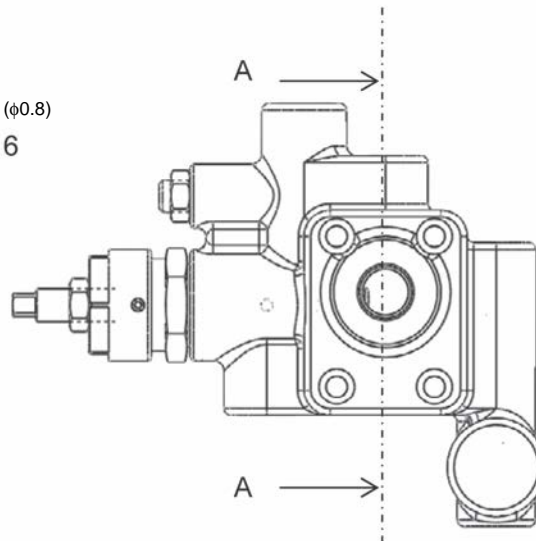
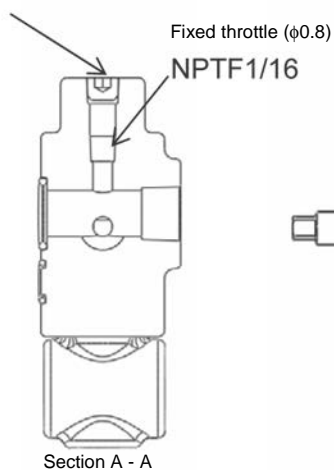

4. Setting the relief valve setting to the maximum (increasing the holding pressure setting)

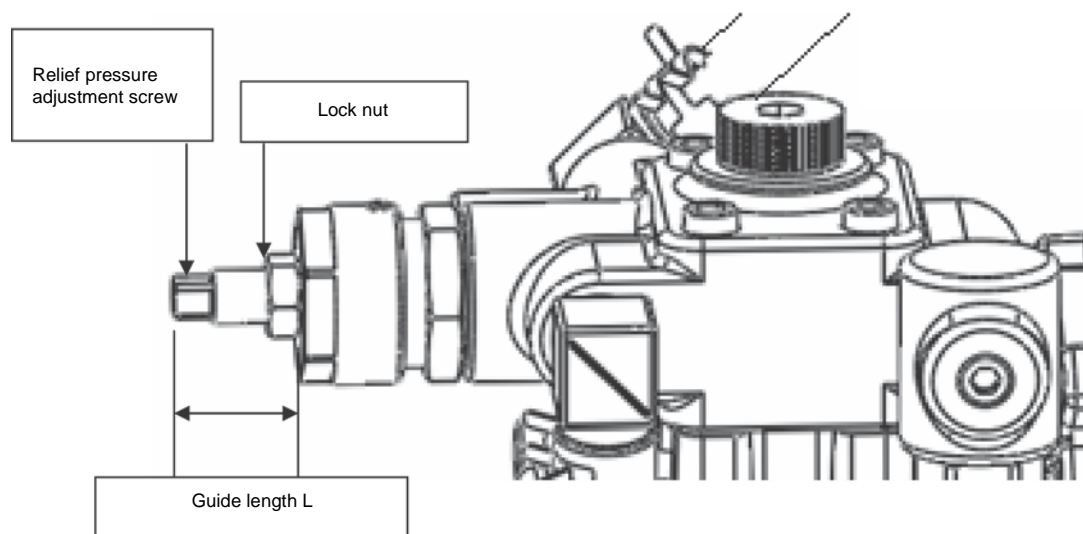

Relief valve

- 1) Loosen the lock nut of the pressure adjustment screw of the relief valve.
 - 2) Tighten the relief pressure adjustment screw by turning it clockwise.
- The length L when the screw is fully tightened is approx. 15 mm.

6 Annexes (Work Procedures Manuals)

5. Changing the holding pressure setting

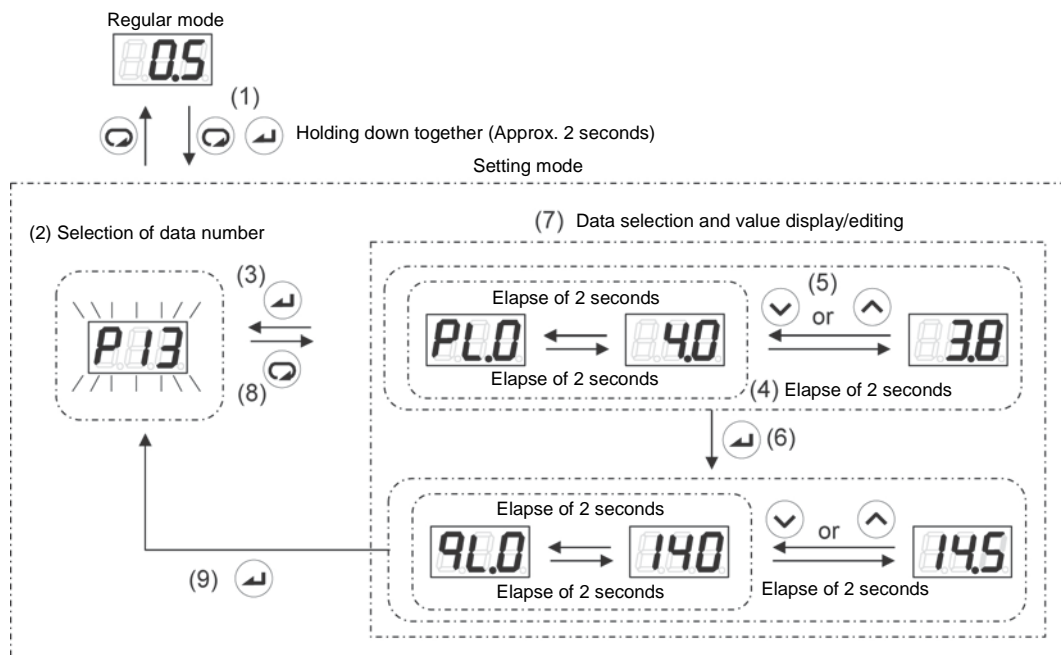

- 1) Hold down the and keys together in the regular mode.
After about 2 seconds, the mode will switch to the setting mode.
- 2) Select P13 with the or key.
During data number selection, the display will flash.
- 3) Confirm the data number by pressing the key.
The value for the selected data number will be displayed.
- 4) The set values for pressure and flow rate in the PQ selection parameters will be displayed alternately at approximately 2-second intervals.
- 5) With the pressure setting "pL.0" displayed, change the set value by incrementing or decrementing it with the and keys.
The data code will be displayed approximately 2 seconds after a set value has been changed.
- 6) Confirm the set value with the key.
The next data code will be displayed.
- 7) Pressing the key will switch the display to the data number selection screen.
Parameters whose values have been changed up until that time will retain the changed values.

6. Increasing the minimum rotation speed (decreasing the holding pressure)

- 1) Display the minimum rotation speed.

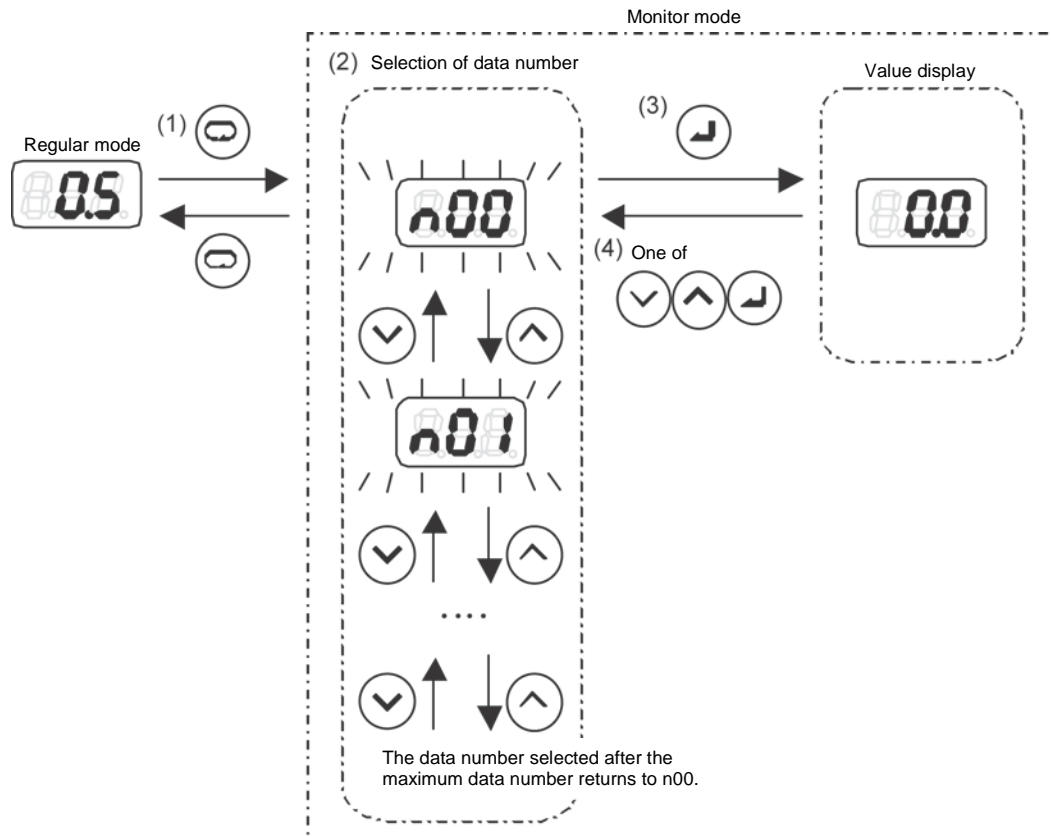

- 2) Loosen the lock nut of the minimum rotation speed adjustment screw.
- 3) Loosen the minimum rotation speed adjustment screw by turning it counterclockwise.

Tightening the screw increases the flow that passes through the throttle and increases the rotation speed.

* Note: If the minimum rotation speed adjustment throttle valve adjustment screw is loosened too far it will come out and oil will spout out.

Ensure that the adjustment screw does not project beyond 19 mm from its mount.

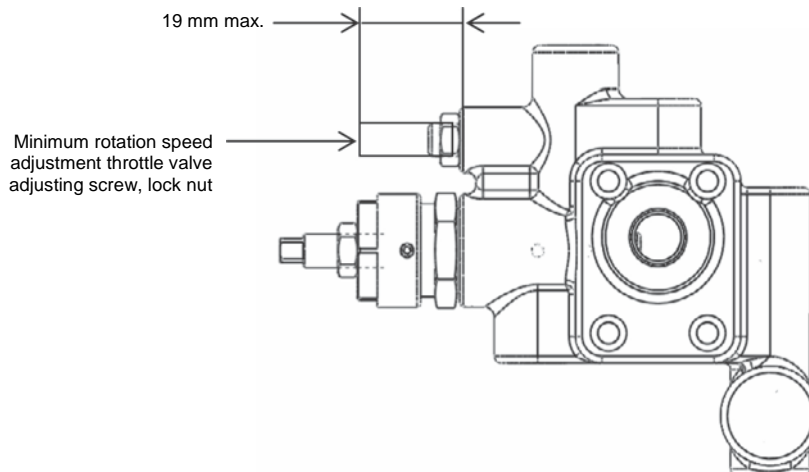

6 Annexes (Work Procedures Manuals)

7. Adjusting the relief valve pressure setting (holding pressure + 0.5 MPa)

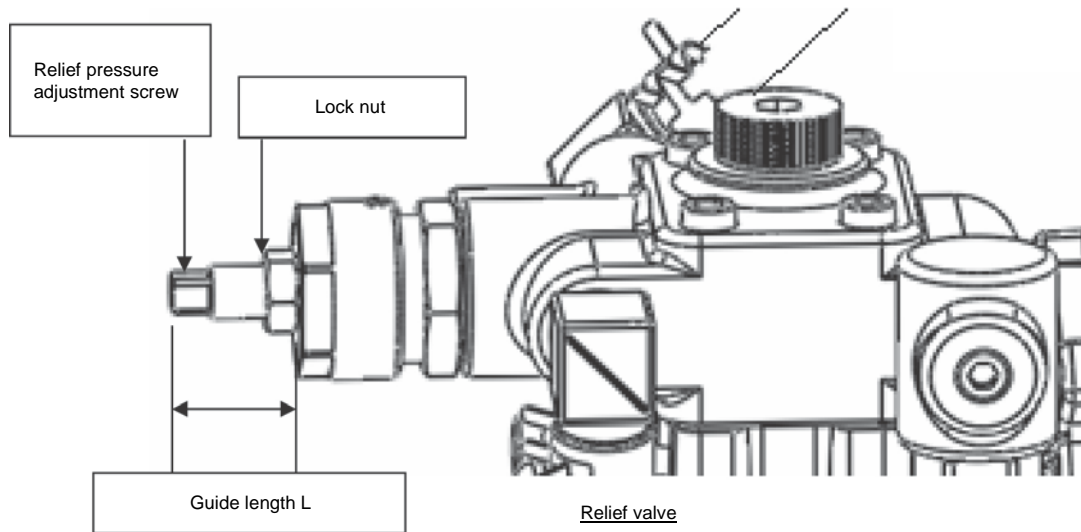

- 1) Carry out the work with the discharge port blocked.
- 2) Loosen the lock nut of the pressure adjustment screw of the relief valve.
- 3) Loosen the relief pressure adjustment screw by turning it clockwise.
Loosen it to a position where the relief valve is actuated: the rotation speed will change suddenly. Check the rotation speed on the operation panel.
- 4) Tighten the adjustment screw until the rotation speed reaches the minimum rotation speed.
From that position, tighten the adjustment screw three-quarters of a turn (270°) further.

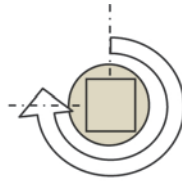

Front view of the adjustment screw

- 5) Tighten the lock nut to secure the adjustment screw.

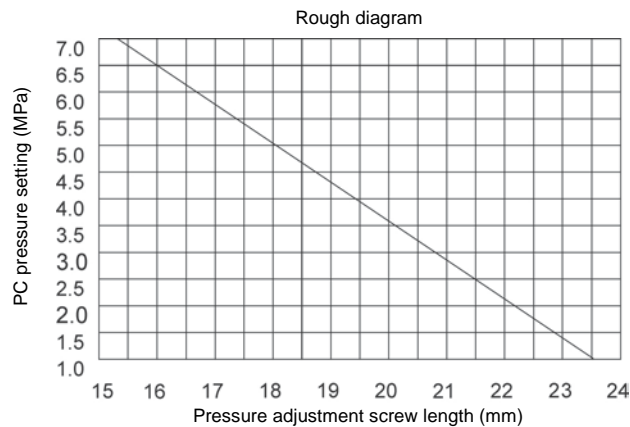

(Alphabetical Order)

Model Name	Page
EHU1404-40-C	140
EHU1404-40-N	140
EHU2504-40-C	140
EHU2504-40-N	140
EHU2507-40-C	140
EHU2507-40-N	140
EHU3007-40-C	140
EHU3007-40-N	140

7 Part List

EHU1404-40-N, EHU1404-40-C, EHU2504-40-N, EHU2504-40-C, EHU2507-40-N, EHU2507-40-C,
EHU3007-40-N, EHU3007-40-C

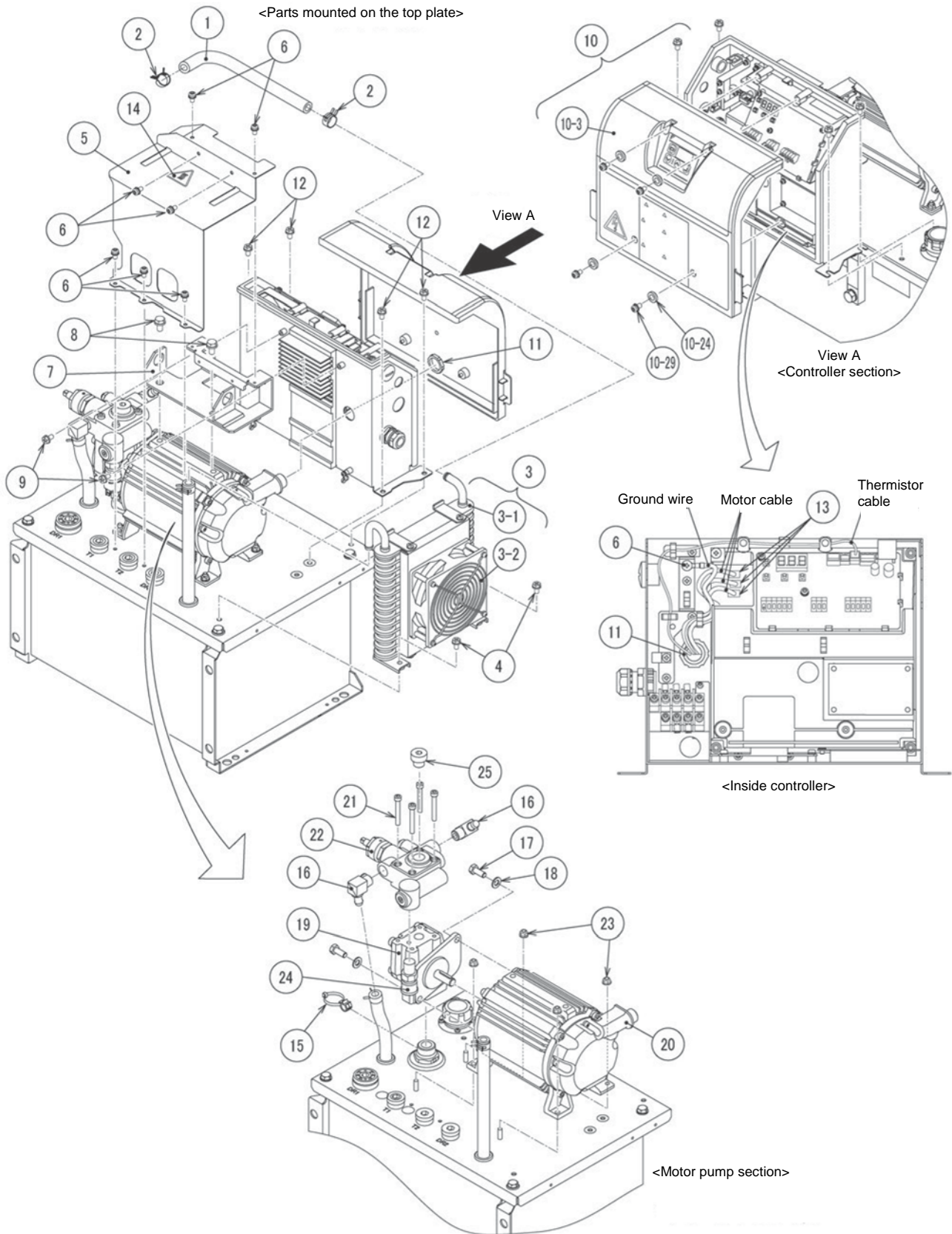

EHU1404-40-N, EHU1404-40-C, EHU2504-40-N, EHU2504-40-C, EHU2507-40-N, EHU2507-40-C,
EHU3007-40-N, EHU3007-40-C

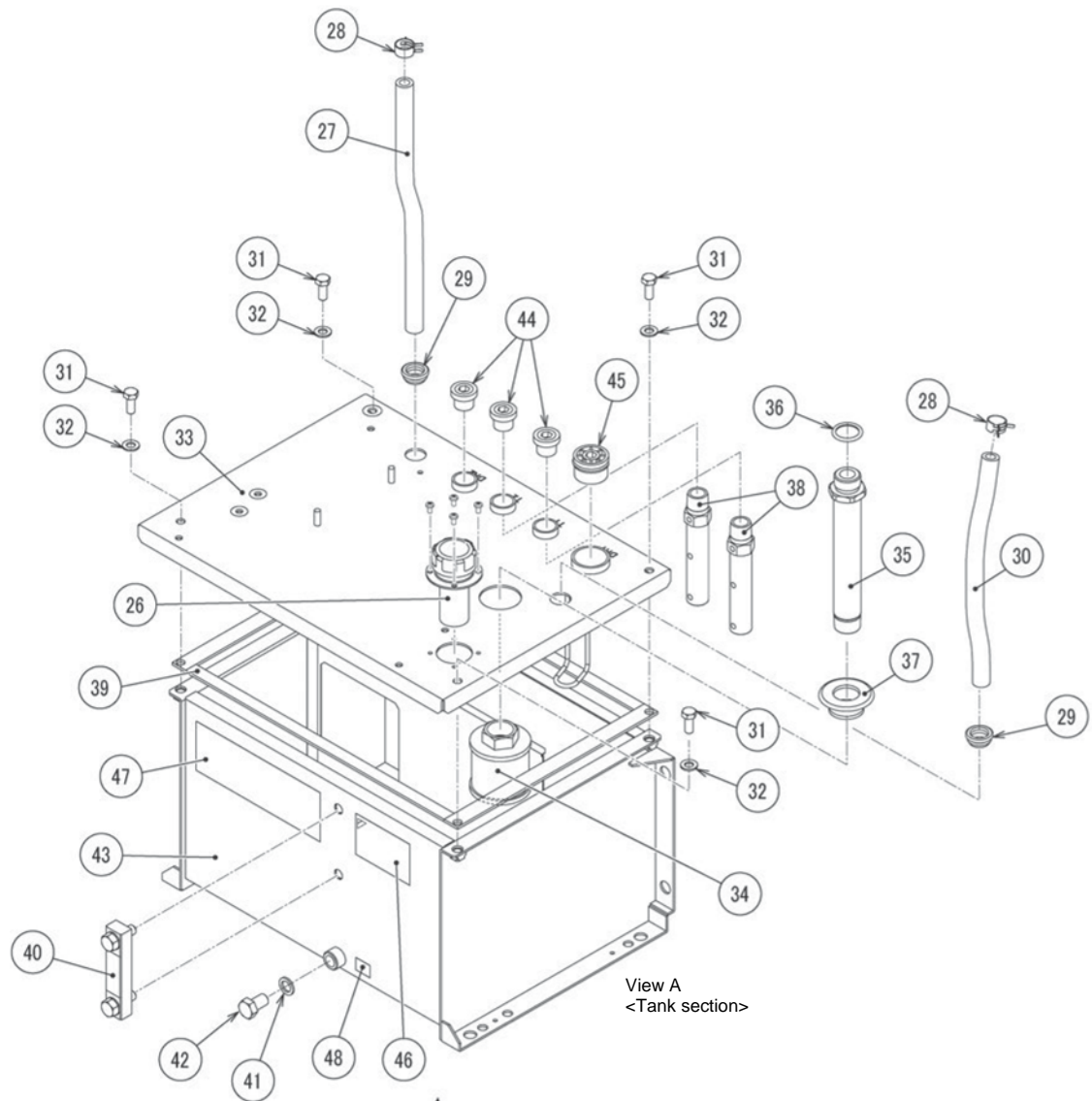

View A
<Tank section>

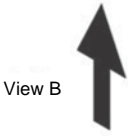

View B

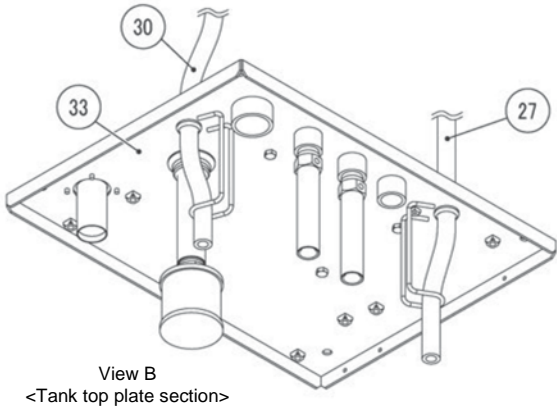

View B
<Tank top plate section>

7 Part List

EHU1404-40-N, EHU1404-40-C, EHU2504-40-N, EHU2504-40-C, EHU2507-40-N, EHU2507-40-C,
EHU3007-40-N, EHU3007-40-C

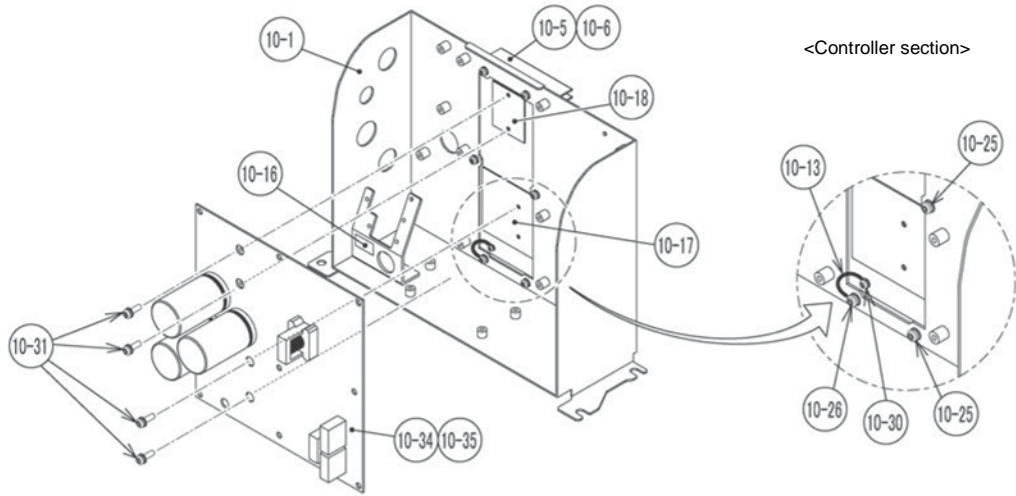

<Controller section>

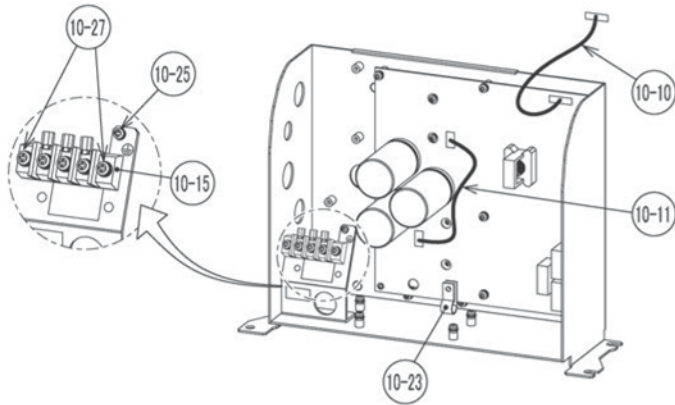

<With EHU1404/EHU2504>

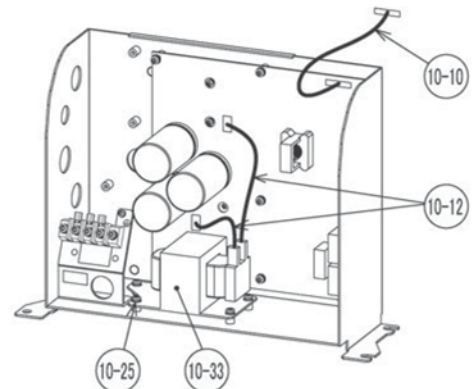

<With EHU2507/EHU3007>

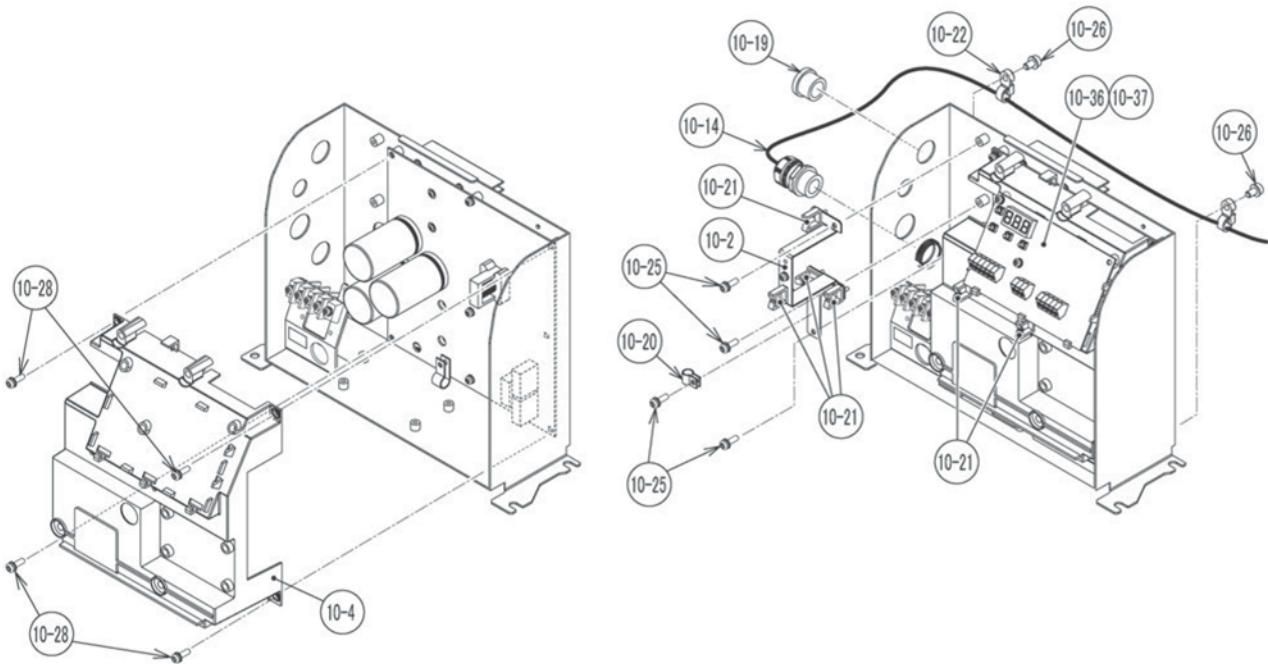

EHU1404-40-N, EHU1404-40-C, EHU2504-40-N, EHU2504-40-C, EHU2507-40-N, EHU2507-40-C, EHU3007-40-N, EHU3007-40-C

No.	Part No.	Part name	Drawing No.	Specifications	Quantity per Unit								Remarks
					EHU 1404 -40-N	EHU 1404 -40-C	EHU 2504 -40-N	EHU 2504 -40-C	EHU 2507 -40-N	EHU 2507 -40-C	EHU 3007 -40-N	EHU 3007 -40-C	
1	2339913	Rubber drainage hose	1734480-18	290L	1	1	1	1	1	1	1	1	
2	2339920	One-touch hose clamp	PP03967-63		2	2	2	2	2	2	2	2	
3		ECORICH MOC oil cooler assembly	PP04161-01		1	1	1	1	1	1	1	1	
3-1	2339937	Oil cooler	20303588-01		1	1	1	1	1	1	1	1	
3-2	2339944	DC fan assembly	PP04072-01		1	1	1	1	1	1	1	1	
4		Cross-recessed hexagon head bolt with washer	PP01393-20	M6 × 20	2	2	2	2	2	2	2	2	
5	2339951	Sound-proof cover	20304051-01		1	1	1	1	1	1	1	1	
6		Cross-recessed pan head screw with washer	PP03865-10	M4 × 10	8	8	8	8	8	8	8	8	
7	2339968	CR stay	20304073-01					1	1	1	1		
7	2339975	CR stay	20304073-02		1	1	1	1					
8		Flanged hexagon head bolt	PP04156-12	M8 × 12	2	2	2	2	2	2	2	2	
9		Hexagon socket head cap sems bolt	PP04064-10	M4 × 10	2	2	2	2	2	2	2	2	
10	2342700	Controller for EHU1404-40	PP04074-000	With software	1								
10	2342717	Controller for EHU2504-40	PP04074-004	With software			1						
10	2342724	Controller for EHU2507-40	PP04074-002	With software				1					
10	2342731	Controller for EHU3007-40	PP04074-003	With software							1		
10	2342748	Controller for EHU1404-40-C	PP04074-000C	With software		1							
10	2342755	Controller for EHU2504-40-C	PP04074-004C	With software			1						
10	2342762	Controller for EHU2507-40-C	PP04074-002C	With software					1				
10	2342779	Controller for EHU3007-40-C	PP04074-003C	With software								1	
10-1		Base frame	20303810-01		1	1	1	1	1	1	1	1	
10-2		Internal sheet metal part	20303809-01		1	1	1	1	1	1	1	1	
10-3	2339982	Exterior cover assembly	20303871-01		1	1	1	1	1	1	1	1	
10-4	2339999	Internal cover	20303804-01		1	1	1	1	1	1	1	1	
10-5		Heatsink	20303807-01		1	1	1	1	1	1	1	1	
10-6		Heatsink packing	20303808-01		1	1	1	1	1	1	1	1	
10-7	2340007	Power supply relay harness (red)	PP03966-01		1	1	1	1	1	1	1	1	Not illustrated
10-8	2340014	Power supply relay harness (white)	PP03966-02		1	1	1	1	1	1	1	1	Not illustrated
10-9	2340021	Power supply relay harness (black)	PP03966-03		1	1	1	1	1	1	1	1	Not illustrated
10-10	2340038	Power/interface communication harness	PP03992-01		1	1	1	1	1	1	1	1	
10-11	2340045	DCL shorting harness	PP03994-01		1	1	1	1					
10-12	2340052	DCL harness	PP03995-01					2	2	2	2	2	
10-13	2340069	Grounding harness	PP04132-01		1	1	1	1	1	1	1	1	
10-14	2340076	Pressure sensor, DC fan harness	PP04042-01		1	1	1	1	1	1	1	1	
10-15	2249104	Power supply terminal block for INV20/30	PP03618-01	Product of HOPPY	1	1	1	1	1	1	1	1	
10-16		Terminal block name plate	20402750-01		1	1	1	1	1	1	1	1	
10-17	2340083	Heat radiation sheet A	20402599-01		1	1	1	1	1	1	1	1	
10-18	2340090	Heat radiation sheet	22400918-01		1	1	1	1	1	1	1	1	
10-19	2249089	Blind plug	PP02757-01	φ20.9	1	1	1	1	1	1	1	1	
10-20	2340108	FG clamp	SP2657-01	FGC-3M4	1	1	1	1	1	1	1	1	

7 Part List

No.	Part No.	Part name	Drawing No.	Specifications	Quantity per Unit								Remarks
					EHU 1404 -40-N	EHU 1404 -40-C	EHU 2504 -40-N	EHU 2504 -40-C	EHU 2507 -40-N	EHU 2507 -40-C	EHU 3007 -40-N	EHU 3007 -40-C	
10-21	2340115	Saddle clip	SP2674-02		6	6	6	6	6	6	6	6	
10-22	2340122	Mounting tie	PP04133-02		1	1	1	1	1	1	1	1	
10-23	2340139	KS clamp	PP04044-02		2	2	2	2	2	2	2	2	
10-24	2340146	Sealing washer	PP04002-04		4	4	4	4	4	4	4	4	
10-25		Sems pan head screw	SP2388-8	M4 × 8	18	18	18	18	22	22	22	22	
10-26		Sems pan head screw	SP2388-10	M4 × 10	3	3	3	3	3	3	3	3	
10-27	2250647	M4 screw	PP03557-15	M4 × 15 trivalent chromium plating	2	2	2	2	2	2	2	2	
10-28	2250623	INV20/30 top cover fixing screw	20402129-01	M4 × 12	4	4	4	4	4	4	4	4	
10-29	2340153	Top cover fixing screw	20402735-01	M4 × 15	4	4	4	4	4	4	4	4	
10-30		Sems pan head screw	SP2389-6	M3 × 6	1	1	1	1	1	1	1	1	
10-31		Cross-recessed pan head screw with washer	SP2389-10	M3 × 10	4	4	4	4	4	4	4	4	
10-32		Model nameplate	20402619-01	1.5 kW 3-phase standard specification	1		1						Not illustrated
10-32		Model nameplate	20402619-02	1.5 kW 3-phase standard specification		1		1					Not illustrated
10-32		Model nameplate	20402619-03	2.8 kW 3-phase standard specification					1		1		Not illustrated
10-32		Model nameplate	20402619-04	2.8 kW 3-phase communications specification						1		1	Not illustrated
10-33	2340160	DCL	PP03986-01						1	1	1	1	
10-34	2340177	Power PCB 50L	PP04075-09	1.5 kW 3-phase standard specification with software	1	1	1	1					
10-35	2340184	Power PCB 80L, 100L	PP04075-10	2.8 kW 3-phase standard specification with software					1	1	1	1	
10-36	2340191	Interface PCB for EHU1404-40	PP04076-000	Standard specification with software	1								
10-36	2340209	Interface PCB for EHU2504-40	PP04076-004	Standard specification with software			1						
10-36	2340216	Interface PCB for EHU2507-40	PP04076-002	Standard specification with software					1				
10-36	2340223	Interface PCB for EHU3007-40	PP04076-003	Standard specification with software							1		
10-37	2340230	Interface PCB for EHU1404-40-C	PP04076-000C	RS422 specification with software		1							
10-37	2340247	Interface PCB for EHU2504-40-C	PP04076-004C	RS422 specification with software				1					
10-37	2340254	Interface PCB for EHU2507-40-C	PP04076-002C	RS422 specification with software						1			
10-37	2340261	Interface PCB for EHU3007-40-C	PP04076-003C	RS422 specification with software								1	
11	2340278	Lock nut	HP30464-1		1	1	1	1	1	1	1	1	
12		Hexagon head bolt with flat washer	SP2774	M6 × 12	4	4	4	4	4	4	4	4	
13	1898185	Positive lock housing	SP2280		3	3	3	3	3	3	3	3	
14		High temperature caution nameplate	20400102-01	32 mm	1	1	1	1	1	1	1	1	
15	2340285	Omega clip tie	PP04092-01		1	1	1	1	1	1	1	1	
16	2340292	Short drainage joint (elbow)	20402489-01		2	2	2	2	2	2	2	2	
17		Hexagon head bolt	ABM0802014	M8 × 20	2	2	2	2	2	2	2	2	
18		Flat washer	SPAM08C	M8	2	2	2	2	2	2	2	2	

No.	Part No.	Part name	Drawing No.	Specifications	Quantity per Unit								Remarks
					EHU 1404 -40-N	EHU 1404 -40-C	EHU 2504 -40-N	EHU 2504 -40-C	EHU 2507 -40-N	EHU 2507 -40-C	EHU 3007 -40-N	EHU 3007 -40-C	
19	1507489	Gear pump	SP2361-02		1	1							
19	1507496	Gear pump	SP2361-01				1	1	1	1	1	1	
20	2340300	Motor	PMMAEZCZ2-10 -3L11		1	1	1	1					
20	2340317	Motor	PMMAEZDZ2-10 -3L11						1	1	1	1	
21	2340324	Hexagon socket head cap bolt	PP02485-45	M6 × 45	4	4	4	4	4	4	4	4	
22	2340331	Relief valve assembly	ENR-V4-10-B		1	1	1	1					
22	2340348	Relief valve assembly	ENR-V7-10-B						1	1	1	1	
23	2340355	Three Lock Nut	PP04070-06	M6	4	4	4	4	4	4	4	4	
24	1629132	Pressure sensor	SP3192	KM15-S49 (10 MPa)	1	1	1	1	1	1	1	1	
25	2052728	Masking plug + O-ring set	HP31581		1	1	1	1	1	1	1	1	
26	1329889	Oil filler port-cum-air breather	HP9549		1	1	1	1	1	1	1	1	
27	1875276	Rubber drainage hose	1734480-10	370 mm	1	1	1	1	1	1	1	1	
28	2339920	One-touch hose clamp	PP03967-63		2	2	2	2	2	2	2	2	
29	2340362	Hose bushing	20402609-01		2	2	2	2	2	2	2	2	
30	2339913	Rubber drainage hose	1734480-18	290 L	1	1	1	1	1	1	1	1	
31		Hexagon head bolt	ABM0802014	M8 × 20	4	4	4	4	4	4	4	4	
32		Flat washer	SPAM08C	M8	4	4	4	4	4	4	4	4	
33	2340379	Tank top plate	20201724-01		1	1	1	1	1	1	1	1	
34	1583337	Suction strainer	SP3167-3	DCH -06A-150	1	1	1	1	1	1	1	1	
35	2340386	Suction pipe	20303778-01	G3/4×R3/4	1	1	1	1	1	1	1	1	
36	1330056	O-ring	KP1B024	P24	1	1	1	1	1	1	1	1	
37	2340393	Suction pipe bushing	20303818-01	φ42	1	1	1	1	1	1	1	1	
38	2340401	TOE resin pipe	20303756-130	R1/2 130L	2	2	2	2	2	2	2	2	
39	2340432	Tank packing	20303777-01		1	1	1	1	1	1	1	1	
40	0197113	Oil level gauge	HP20319	KLA-80A	1	1	1	1	1	1	1	1	
41	1341446	Sealing washer	LBM120190E	WF 12,19,2	1	1	1	1	1	1	1	1	
42	2340449	Hexagon head bolt	PP04065-20	M12 × 20 trivalent chromium plating	1	1	1	1	1	1	1	1	
43	2340456	Tank	20201759-01	18L	1	1	1	1	1	1	1	1	
44	2133696	Hexagon socket plug with O-ring	1945902-04	1/2B	3	3	3	3	3	3	3	3	
45	1868867	Hexagon socket plug with O-ring	1945902-2	1B	1	1	1	1	1	1	1	1	
46		Unit name plate	20402746-01		1								
46		Unit name plate	20402747-01				1						
46		Unit name plate	20402748-01					1					
46		Unit name plate	20402749-01							1			
47		Caution nameplate	1733999		1	1	1	1	1	1	1	1	
48		Oil sampling/oil drain port nameplate	Y4426766		1	1	1	1	1	1	1	1	

7 Part List

MEMO

DAIKIN INDUSTRIES, LTD.

Oil Hydraulic Equipment

Osaka Office

YODOGAWA PLANT

1-1, Nishi-Hitotsuya, Settsu, Osaka 566-8585, Japan

Phone: 81-6-6349-4475

Fax.: 81-6-6349-7862

Home Page: <http://www.daikinpmc.com/en/>

Contact: <http://www.daikin.com/contact/hydraulic/>

For requirements on Maintenance Repair Operation;

All World Machinery Supply, Inc.

a member of Daikin Group

6164 All World Way, Roscoe, IL 61073, U. S. A.

Phone: +1-815-943-9111

Fax.: +1-815-943-5370

Home Page: <http://www.allworldmachinery.com/us/>