

ENGINEERING
TOMORROW



Technical Information

Displays

DP6XX Series



Revision history

Table of revisions

Date	Changed	Rev
November 2016	Minor update	0302
June 2016	Various updates from PAE; updated to Engineering Tomorrow design	0301
December 2015	Converted to Danfoss layout	0204
June 2011	DC supply current maximum ratings	BC
January 2007	Various	BB
August 2005	Various	BA
October 2005	First edition	AA

Contents

Literature references

DP6XX reference literature.....	4
Technical Information (TI).....	4
Data Sheet (DS).....	4
PLUS+1® GUIDE User Manual.....	4
Latest version of technical literature.....	4

User liability and safety statements

OEM responsibility.....	5
-------------------------	---

Overview

Features.....	6
---------------	---

Ordering information

Product naming convention.....	7
Related products.....	7

Input/outputs

Inputs.....	9
Digital/analog.....	9
Multifunction.....	10
USB.....	12
Video.....	12

Controller Area Network (CAN) specifications

CAN shield/analog inputs.....	13
CAN/RedCAN communication.....	13

Product ratings

General technical specifications.....	14
Supply voltage/maximum current ratings.....	15
Testing criteria.....	16

Maintenance guidelines

LCD module	17
------------------	----

Installation

Dimensions.....	18
Two mounting options.....	19
Flush mounted.....	19
Stand-alone on post.....	20
Pin assignments.....	21
Pinout.....	22
Machine wiring guidelines.....	23
Machine welding guidelines.....	23

Literature references

DP6XX reference literature

References

Literature title	Literature type	Literature number
<i>DP6XX Series PLUS+1® Mobile Machine Displays</i>	Technical Information	BC00000108
<i>DP600 Series PLUS+1® Mobile Machine Displays</i>	Data Sheet	AI00000079
<i>DP6XX Series PLUS+1® Mobile Machine Displays</i>	Data Sheet	AI00000038
<i>PLUS+1® GUIDE Software User Manual</i>	Operation Manual	AQ00000026

Technical Information (TI)

A TI is comprehensive information for engineering and service personnel to reference.

Data Sheet (DS)

A DS is summarized information and parameters that are unique to a specific model.

PLUS+1® GUIDE User Manual

This user operation manual (OM) details information regarding the PLUS+1® GUIDE tool set that is used to build PLUS+1® applications. This OM covers the following broad topics:

- How to use the GUIDE graphical application development tool to create machine applications
- How to configure module input and output parameters
- How to configure module input and output parameters
- How to download GUIDE applications to target PLUS+1® hardware modules
- How to upload and download tuning parameters
- How to use the PLUS+1® Service Tool

Latest version of technical literature

Danfoss product literature is online at: <http://powersolutions.danfoss.com/literature/>

User liability and safety statements

OEM responsibility

The OEM of a machine or vehicle in which Danfoss products are installed has the full responsibility for all consequences that might occur. Danfoss has no responsibility for any consequences, direct or indirect, caused by failures or malfunctions.

- Danfoss has no responsibility for any accidents caused by incorrectly mounted or maintained equipment.
- Danfoss does not assume any responsibility for Danfoss products being incorrectly applied or the system being programmed in a manner that jeopardizes safety.
- All safety critical systems shall include an emergency stop to switch off the main supply voltage for the outputs of the electronic control system. All safety critical components shall be installed in such a way that the main supply voltage can be switched off at any time. The emergency stop must be easily accessible to the operator.

Overview

Features

- External NAV button allows navigation through all DP6XX functions. Mount NAV button so that the driver can navigate securely in all situations during work and travel.
- Built-in real-time clock enables machine use time tracking as well as data logging.
- CAN, RedCAN, RS-232, and USB interfaces as a gateway for updating and diagnosing all machine control systems.
- Powerful 32-bit microprocessor produces smooth, flicker-free movements of gauges and readouts in the display screen.
- Anti-glare display screen and sensor-controlled backlight levels provide superior legibility under all operating conditions, whether freestanding or dash-mounted.
- Video input option allows display of inputs from two standard composite video observation cameras.
- Rugged, shock-resistant construction protects against dust and resists the effects of moisture by fresh water.
- GORE-TEX® membrane vent keeps moisture from fogging its display screen.
- High brightness LED and digital alarm output alert the operator to alarm states under all operating conditions.
- Complete system software updates are possible through the CAN network.
- Environmental and EMC standards are met according to Danfoss standards defined for mobile applications.
- High performance 32 bit microcontroller for real-time screen updates.
- Smooth and flicker-free/accurate movement of virtual gauges and needles.
- Ample onboard flash/RAM memory.
- Data logging capabilities.
- USB port for fast software download and uploads.
- Same outside dimensions for screen variants.
 - Color: advanced TFT 400 x 240 pixels, transreflective, 256 colors
 - Monochrome: LED 320 x 240 pixels, transreflective
- Two mounting options.
 - Flush mount in dashboard
 - Stand alone on post according to VESA standard 75mm x 75mm [2.953 in x 2.953 in]
- Fully integrated connectors and silicone keypad provide water and dust protection from all sides.
- Designed to withstand high-levels of shock/vibration.
- Extremely wide storage and operating temperature range.
- Keypad with 14 buttons (8 soft-keys + 6 buttons for navigation).
- All buttons have green backlight design for low light and night use.
- Ultra-bright red/amber/green alarm LED.
- 2 shielded Binder connectors for USB, RS-232 and camera inputs.
- 2 CAN ports, one fully compatible to RedCAN™, for enhanced safety and reliability in mobile control systems.
- Integrated light sensor for automatic backlight adjustment.
- 2 DEUTSCH DTM connectors.
- Works with either 12 Vdc or 24 Vdc power supplies.

Ordering information

Product naming convention

DP6XX model code

A				B		C		D		E	
D	P	6								K	S

Product configuration model code

A	B	C	D	E	Part number
DP600	SA	CA	V2	KS	10100890
DP610	SA	CB	V0	KS	10100889
DP620	SB	CB	V0	KS	10100888

A—Model name

Code	Description
DP600	PLUS+1® Mobile Machine Displays
DP610	
DP620	

B—Screen variant

Code	Description
SA	400 x 240 color advanced TFT transfective
SB	320 x 240 monochrome transfective

C—Connector

Code	Description
CA	C1 + C2 + C3 + C4 (only with video option D = V2)
CB	C1 + C2 + C3 (without video option D = V0)

D—Video inputs

Code	Description
V0	No video inputs
V2	Supports two external video signals (one at a time) as input (Either PAL or NTSC format)

E—Keypad

Code	Description
KS	Standard keypads with 8 soft- and 6 function-keys

Related products

Electrical parts

10100728	5-pin male Binder connector (includes 2m cable)
10100729	7-pin male Binder connector (includes 2m cable)
10100738	DTM06-12SA, 12-pin Deutsch connector

Ordering information

Electrical parts (continued)

10100739	DTM06-6S 6-pin Deutsch connector
10100741	WM 12S locking plug for 10100738 Deutsch connector
10100742	WM6S locking plug for 10100739 Deutsch connector
10100743	0462-201-20141, Deutsch terminal for DTM06-xS
10103497	USB cable

Electrical connection kits

10100868	DP600 connection kit <i>Contents:</i> 10100728 5-pin male Binder connector 10100729 7-pin male Binder connector 10100944 12-pin DEUTSCH connection kit 10103494 6-pin DEUTSCH connection kit
10100944	12-pin DEUTSCH connection kit <i>Contents:</i> 10100738 DTM06-12SA 12-pin DEUTSCH connector 10100743 DEUTSCH terminal 10100741 WM 12S locking plug
10103494	6-pin DEUTSCH connection kit <i>Contents:</i> 10100739 DTM06-6S 6-pin DEUTSCH connector 10100743 DEUTSCH terminal 10100742 WM 6S locking plug
10103495	DEUTSCH IP67 Seal Kit
10103496	Binder IP67 Seal Kit

Connection tools

10100744	DEUTSCH stamped contacts terminal crimp tool, size 20
10100745	DEUTSCH solid contacts terminal crimp tool

Software

11179523 (annual renewal with 11179524 to keep the software updates)	PLUS+1* GUIDE Professional Software (includes 1 year of software updates, a single user license, Service and Diagnostic Tool and Screen Editor)
---	--

Input/outputs

Inputs

This series of displays support the following pin types:

- Digital or Analog (DIN/AIN)
- Multifunction (DIN/AIN/FreqIN, Rheo, 4–20 mA)
- Analog or Temperature or Rheostat (AIN/Temp/Rheo)
- Fixed Range Analog or CAN shield (AIN/CAN shield)

This series of displays have input pins that support multiple functions. Pins that support multiple input types are user-configurable using PLUS+1® GUIDE software.

Digital/analog

High level digital input

Description	Unit	Minimum	Maximum	Typical	Comment
Voltage range	V	0 to 69.3	0 to 84.7	—	—
Input resistance	kΩ	—	—	105	no pull up/down
				13	With pull up to 5 V
				13	Pull down to ground
				7	With pull up and down to 5 V
Programmable low threshold voltage	V	0	?	—	—
Programmable high threshold voltage	V	0	?	—	—
Rise time	μs	—	—	20	—
Fall Time	μs	—	—	20	—

High level analog input

Description	Unit	Minimum	Maximum	Typical	Comment
Voltage range	V	0 to 69.3	0 to 84.7	—	—
Input resistance	kΩ	—	—	105	no pull up/down
				13	With pull up to 5 V
				13	Pull down to ground
				7	With pull up and down to 5 V
Analog voltage error (± 300 mV + U _{in} × 3.4%)	mV	0	—	± 260	U _{in} = 0 V
				± 2920	U _{in} = 70 V
Bandwidth	kHz	—	—	6	—

Input/outputs

Multifunction

Low level digital input

Description	Unit	Minimum	Maximum	Typical	Comment
Voltage range	V	0	63	—	—
Input resistance	k Ω	—	—	233	no pull up/ down
				14	With pull up to 5 V
				14	Pull down to ground
				73	With pull up and down to 5 V
Programmable low threshold voltage	V	0	?	—	—
Programmable high threshold voltage	V	0	?	—	—
Rise time	μ s	—	—	20	—

Low level analog input

Description	Unit	Minimum	Maximum	Typical	Comment
Voltage range	V	0	63	—	—
Input resistance	k Ω	—	—	233	no pull up/ down
				14	With pull up to 5 V
				14	Pull down to ground
				7.3	With pull up and down to 5 V
Analog voltage error	mV	—	—	± 0.5	$U_{in} = 0$ V
				± 19	$U_{in} = 5$ V
Bandwidth	kHz	—	—	6.8	—

High level digital input

Description	Unit	Minimum	Maximum	Typical	Comment
Voltage range	V	0	70	—	—
Input resistance	k Ω	—	—	105	no pull up/ down
				13	With pull up to 5 V
				13	Pull down to ground
				7	With pull up and down to 5 V
Programmable low threshold voltage	V	0	?	—	—
Programmable high threshold voltage	V	0	?	—	—

Input/outputs

High level digital input (continued)

Description	Unit	Minimum	Maximum	Typical	Comment
Rise time	μs	—	—	20	—
Fall time	μs	—	—	20	—

High level analog input

Description	Unit	Minimum	Maximum	Typical	Comment
Voltage range	V	0	70	—	—
Input resistance	kΩ	—	—	105	no pull up/ down
				13	With pull up to 5 V
				13	Pull down to ground
				7	With pull up and down to 5 V
Analog voltage error (± 300 mV + U _{in} × 3.4%)	mV	—	—	± 100	U _{in} = 0 V
				± 2760	U _{in} = 70 V
Bandwidth	kHz	—	—	7.1	—

Resistance input

Description	Unit	Minimum	Maximum	Typical	Comment
Resistance range	kΩ	0	10	—	—
Input resistance	Ω	—	1.33	—	Pull up to 5V
Resistance error	Ω	—	± 5 ± 9	—	R = 0 kΩ R = 10 kΩ

Current input

Description	Unit	Minimum	Maximum	Typical	Comment
Current range	—	0 to 53	0 to 65	—	Shut off at 50 mA
Input resistance	Ω	—	—	100	2.0V at 20 mA input current
Current error (± 3.5%)	mA	—	± 0.08 ± 0.7	—	I _{in} = 0 mA I _{in} = 20 mA

Frequency input

Description	Unit	Minimum	Maximum	Typical	Comment
Frequency range	kHz	0	10	—	—

Input/outputs

USB

USB input/output parameters

Description	Unit	Minimum	Typical	Maximum	Comment
2.0 full speed	Mbit/s	—	12	—	—
Vbus input voltage	Volt	—	> 4.4	—	—
Vbus input resistance	k Ω	—	70	—	Vbus > 5.25 V
Short circuit protection (No damage)	V	0	—	70	—
Vbus output voltage	V	4.75	—	5.25	—
Vbus output current	A	—	0.5	—	—
Vbus short current	A	—	—	1.1	—

Video

Video output

Description	Unit	Minimum	Typical	Maximum	Comment
Short circuit protection	V	0	—	70	—
12 V output voltage (9 V > Ubat > 70 V)	V	11.5	12	12.7	—
12 V output current	A	—	0.5	—	Vbus > 5.25 V
24 V output voltage (9 V > Ubat > 70 V)	V	23	24	26	—
24 V output current	A	—	—	0.25	—
Video formats	NTSC, PAL, SECAM	—	—	—	Composite video

To power the camera up, it is recommended to use the display as power supply. If using a different power supply, it should meet the specification of the camera in regards of the voltage type and range, the current and voltage amount it can supply to its load, stability of the output voltage and current under varying line and load conditions, operating/storage temperature ranges.

[The use of a different power supply for the camera can create "noise" on the signal line which will affect its functionality.](#)

Controller Area Network (CAN) specifications

CAN shield/analog inputs

CAN shield

Description	Unit	Minimum	Maximum	Typical	Comment
Input impedance	—	—	—	1 μ F + 1 Ω	—

Analog input (5 V only)

Description	Unit	Minimum	Maximum	Typical	Comment
Voltage range	V	0	5.4		—
Input resistance	k Ω	—	—	233	—
Analog voltage error $\pm (20 \text{ mV} + U_{in} \times 1.6 \%)$	mV	—	± 20 ± 120	—	$U_{in} = 0 \text{ V}$ $U_{in} = 5 \text{ V}$
Bandwith	kHz	—	—	2	—

CAN/RedCAN communication

CAN/RedCAN

Description	Unit	Minimum	Maximum	Typical	Comment
Available Baud rates	kbps	0.01	100	50	With 120 Ω termination
				100	
				125	
				250	
				500	
				1000	
Maximum input voltage range	V	0	70	—	—

Product ratings

General technical specifications

Operating voltage range	9 to 70 VDC
Power consumption	15 W max
Digital Inputs (3)	U _{in} < 1.5 VDC logical low U _{in} > 1.5 VDC logical high 2 inputs designed for 90° A/B encoder signals, menu NAV button
Option: Video inputs (2)	Standard composite PAL video signal input.
Output for buzzer (1)	low side, max 0.5 A
Camera power output	12V, Max. output current: 400 mA
Camera video input	Composite video, 1V peak-peak
CAN interface for external NAV	2 CAN ports according to CAN specification 2.0 B (active). 250 kbit standard setting (recommended) Baud rates: 111kbit, 250 kbit, 500kbit, 1 Mbit 2 pins for CAN shield according to J1939. One CAN port, fully compatible to Danfoss RedCAN standard.
Encoder inputs	Logical inputs: 5V Logical 0: U _{in} < 1.5V Logical 1: U _{in} > 3.5V Input impedance: 100kΩ Max. frequency input: 100 Hz
Encoder supply	5V, Max. output current 400 mA
Communication	USB RS-232: Baud rates: 1200, 2400, 9600, 19200, 28800, 38400, 115200 baud. No handshake available.
Memory	8MB RAM 8K FRAM parameter memory (256 byte available for application data storage).
Electrical connections	1 Deutsch DTM 12-pin connector, Code C1 1 Deutsch DTM 6-pin connector, Code C2 1 Binder 7-pin connector for USB/RS-232, Code C3 1 Binder 5-pin connector for video-signals, Code C4
Operating temperature	DP600; DP610: -30 °C — +70°C [-22°F — +158° F] DP620: -20 °C — +70°C [-4°F — +158°F]
Storage temperature	DP600; DP610: -40 °C — +85°C [-40°F — +185° F] DP620: -30 °C — +80°C [-22°F — +176°F]
Moisture Ingression	IP67, in accordance with SS-EN 60 529 Unused connections must have sealing plugs for IP rating to be valid.
Vibration	IEC 60068-2-64-Fh with severity according to IEC TR 60721-4-5 environmental class 5M3
Shock	IEC 60068-2-27-Ea with severity according to IEC TR 60721-4-5 environmental class 5M3; free fall according to IEC 68-2-32Ed
Electrical	Automotive transients ISO 7637/1-2 Automotive transients ISO 7637/3
EMC emission	EN 61000-6-3
EMC immunity	EN 61000-6-2

Product ratings

Membrane switches	14 keys 1 million cycles endurance Pressure force: 300 gram (+/- 30 grams)
Real time clock	Date & Time Backup time: minimum 1 month Accuracy: 1 sec/24 hours
Programmable ambient light sensor	OSRAM SFH3410
Faceplate	Ultra bright faceplate-integrated red LED alarm

Supply voltage/maximum current ratings

DP6XX graphical displays are designed to operate with a nominal 9 to 63 Vdc power supply with reverse polarity protection.

Supply voltage

Description	Unit	Minimum	Maximum	Comment
DC supply voltage	Volt	9	70	With reverse polarity protection
DC supply current (circuit board only)	mA	2.5		UBat = 8V
		30		UBat = 14V
		70		UBat = 28V
		40		UBat = 70V
Power supply interruption (without rebooting)	ms	34		
		36		
		46		
		100		
Load dump protection, 12V systems, % pulses, cycle time 100 s, criteria C	V	87		According to ISO 7637-2
	Ω	1		
	ms	200		
	ms	5		
Load dump protection, 28V systems, % pulses, cycle time 100 s, criteria C	V	183		According to ISO 7637-2
	Ω	3		
	ms	200		
	ms	10		
Load dump protection, 36V systems, % pulses, cycle time 100 s, criteria C	V	200		According to ISO 7637-2
	Ω	4.3		
	ms	200		
	ms	10		
Load dump protection, 48V systems, % pulses, cycle time 100 s, criteria C	V	200		According to ISO 7637-2
	Ω	6.3		
	ms	200		
	ms	10		

5 V reference output

Description	Unit	Minimum	Maximum
Output voltage	V	4.8	5.2
Output current	A	0.5	—
Output short circuit	A	—	0.9
Short circuit protection	V	0	70

Product ratings

Testing criteria

Climatic

Condition	Rating
Cold/heat storage and operation	IEC 60068-2-1, IEC 60068-2-2
Fogging	IEC 60068
Temperature change	IEC 60068-2-30
Moisture ingress	IEC 60529
Sunlight visibility	IEC 68-2-5

Chemical

Condition	Rating
Chemical resistance	ISO 16750-5

Mechanical

Condition	Rating
Vibration, resonance	IEC 60068-2-6
Vibration, operation	IEC 60068-2-64
Bump	IEC 60068-2-29
Shock	IEC 60068-2-27
Free fall	IEC 60068-2-32

Maintenance guidelines

Opening the display's housing voids the factory warranty.

LCD module

Caution

Prolonged exposure to direct intense sunlight can cause premature failure of the LCD module. This risk can be reduced by providing shading or mounting the display at an incline rather than the horizontal.

Caution

The protective glass will break if hit with a hard or heavy object. If the protective glass is broken, remove the display from your machine then return the display to Danfoss to be serviced.

Clean the display's housing and protective glass with a clean, soft, damp cloth, or mild dishwashing detergent because abrasive pads or solvents, including alcohol, benzene, and paint thinner can cause scratching and discoloration.

Installation

Dimensions

DP600, DP610, DP620 Series Displays dimensions in millimeter [inches]

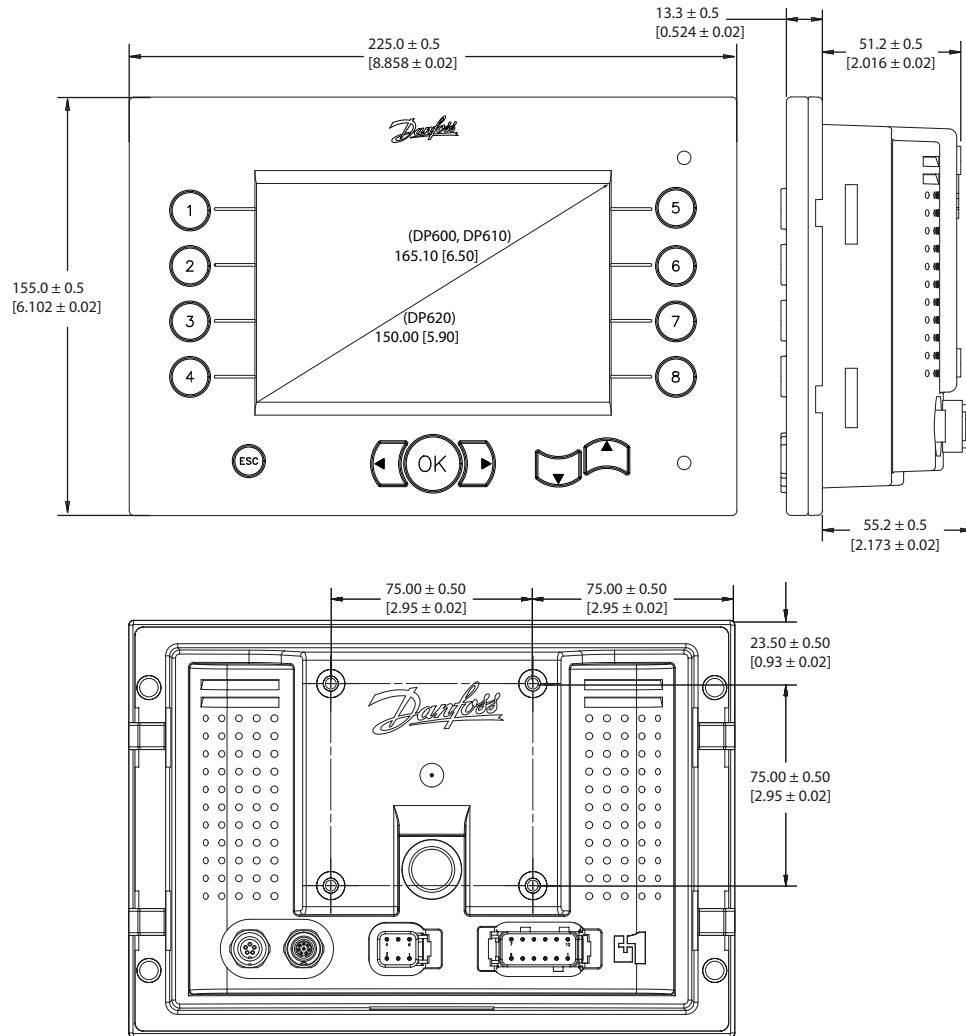

kwa1463500663772

Installation

Two mounting options

Flush mounted

Use the DP600 panel mounting spring clip to flush-mount display into a dashboard.

Panel cutout (mm [in]) and panel mounting spring clip

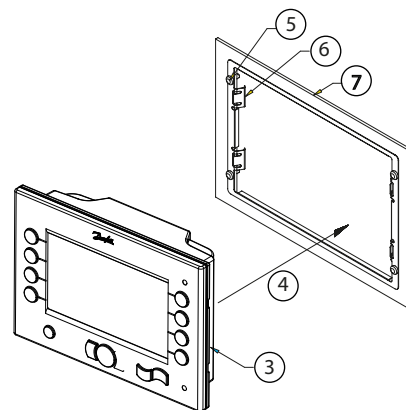
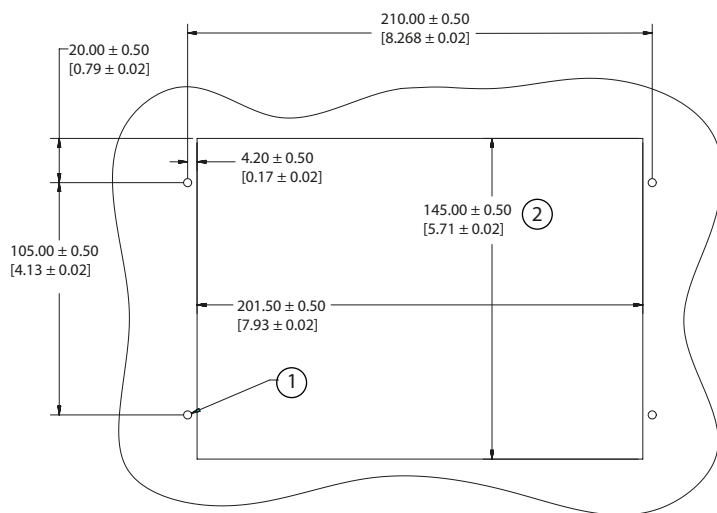

P200164

1. 4 x hole for M4 screw
2. Panel cutout
3. Display assembly
4. Snap in
5. 4 x M4 screw
6. Spring clip
7. Panel

Installation

Stand-alone on post

Mount according to VESA (Video Electronics Standards Association) Mount Standards The VESA hole pattern for this display is: 75.00 mm x 75.00 mm (02.95 in x 02.95 in).

Post mounting option (mm [in])

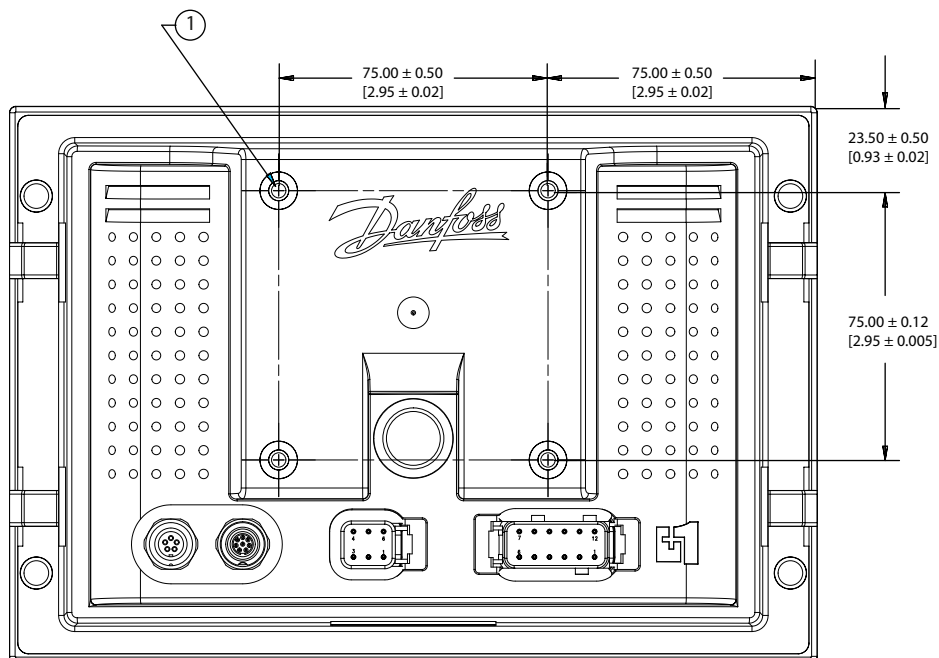

P200161

1. 4 x hole for M4 screw x 0.7 mm (0.03 in) x 11 mm (0.43 in) maximum depth

Disconnect your machine's battery power before connecting power and signal cables to the display.

Installation

Pin assignments

DP6XX series, pin assignments

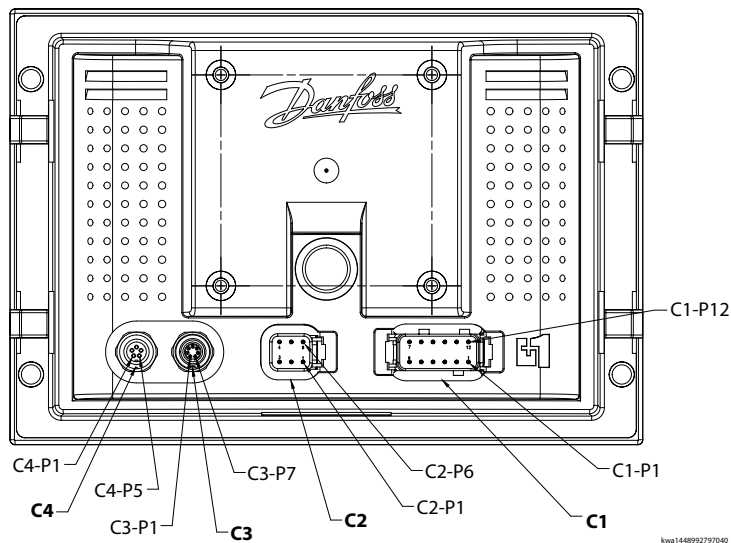

Pin connectors

C4



C3



C2

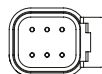

C1

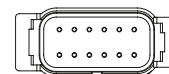

P200163

Pin assignments

Binder 702 series 5-pin		Binder 702 series 8-pin		DEUTSCH DTMO6 6-pin		DEUTSCH DTMO6 12-pin	
C4 pin	Function	C3 pin	Function	C2 pin	Function	C1 pin	Function
1	Video power ground	1	USB power bus	1	Redundant power ground	1	Main power ground
2	Video power 12/24 Vdc out	2	USB data -	2	Redundant power supply	2	Main power supply
3	Video input 1	3	USB data +	3	RedCAN left bus - CAN0 +	3	CAN bus - CAN1 +
4	Video ground	4	USB ground	4	RedCAN left bus - CAN0 -	4	CAN bus - CAN1 -
5	Video input 2	5	Ground	5	CAN shield	5	CAN shield
		6	RS-232 RxD	6	Analog in	6	RedCAN right bus - CAN0 +
		7	RS-232 TxD			7	RedCAN right bus - CAN0 -
						8	Encoder supply
						9	Encoder pulse A input
						10	Encoder pulse B input
						11	Encoder enter input
						12	Buzzer - ground

Installation

Pinout

DEUTSCH DTM06-12

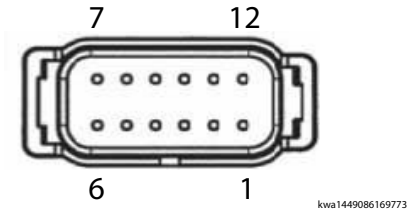

DEUTSCH DTM06-12 connector

Pin	DP600	DP610	DP620
1	Pwr Ground (-)	Pwr Ground (-)	Pwr Ground (-)
2	Pwr Supply (+)	Pwr Supply (+)	Pwr Supply (+)
3	CAN1 High	CAN0 High	CAN0 High
4	CAN0 Low	CAN0 Low	CAN0 Low
5	AIN/CAN Shield	AIN/CAN Shield	AIN/CAN Shield
6	CAN0 High	CAN0 High	CAN0 High
7	CAN0 Low	CAN0 Low	CAN0 Low
8	Sensor Supply	Sensor Supply	Sensor Supply
9	Multi Input*	Multi Input*	Multi Input*
10	Multi Input*	Multi Input*	Multi Input*
11	Digital/Analog In	Digital/Analog In	Digital/Analog In
12	Digital Out	Digital Out	Digital Out

* Multifunction inputs include the following software configurable inputs: Din/AIN/FreqIN, Rheo, 4–20 mA IN

DP600 Binder Series 702 8 pin USB and 5 pin connector



DP600 Binder Series

Pin	DP600 Binder Series 702 USB	Pin	DP600 Binder Series
	Connector 3 pinout		Connector 4 pinout
1	Vbus	1	Video Ground
2	Data -	2	Video Power
3	Data +	3	Video In
4	N/C	4	Video Ground
5	Ground	5	Video Input
6	N/C		
7	N/C		
8	N/C		

Installation

Machine wiring guidelines

- Protect wires from mechanical abuse, run wires in flexible metal or plastic conduits.
- Use 85° C (185° F) wire with abrasion resistant insulation and 105° C (221° F) wire should be considered near hot surfaces.
- Use a wire size that is appropriate for the module connector.
- Separate high current wires such as solenoids, lights, alternators or fuel pumps from sensor and other noise-sensitive input wires.
- Run wires along the inside of, or close to, metal machine surfaces where possible, this simulates a shield which will minimize the effects of EMI/RFI radiation.
- Do not run wires near sharp metal corners, consider running wires through a grommet when rounding a corner.
- Do not run wires near hot machine members.
- Provide strain relief for all wires.
- Avoid running wires near moving or vibrating components.
- Avoid long, unsupported wire spans.
- Ground electronic modules to a dedicated conductor of sufficient size that is connected to the battery (-).
- Power the sensors and valve drive circuits by their dedicated wired power sources and ground returns.
- Twist sensor lines about one turn every 10 cm (4 in).
- Use wire harness anchors that will allow wires to float with respect to the machine rather than rigid anchors.

 **Caution**

Unused pins on mating connectors may cause intermittent product performance or premature failure. Plug all pins on mating connectors.

 **Warning**

Unintended movement of the machine or mechanism may cause injury to the technician or bystanders. Improperly protected power input lines against over current conditions may cause damage to the hardware. Properly protect all power input lines against over-current conditions.

Machine welding guidelines

 **Warning**

High voltage from power and signal cables may cause fire or electrical shock, and cause an explosion if flammable gasses or chemicals are present. Disconnect all power and signal cables connected to the display before performing any electrical welding on a machine.

The following is recommended when welding on a machine equipped with electronic components:

- Turn the engine off.
- Remove electronic components from the machine before any arc welding.
- Disconnect the negative battery cable from the battery.
- Do not use electrical components to ground the welder.
- Clamp the ground cable for the welder to the component that will be welded as close as possible to the weld.

Products we offer:

- Bent Axis Motors
- Closed Circuit Axial Piston Pumps and Motors
- Displays
- Electrohydraulic Power Steering
- Electrohydraulics
- Hydraulic Power Steering
- Integrated Systems
- Joysticks and Control Handles
- Microcontrollers and Software
- Open Circuit Axial Piston Pumps
- Orbital Motors
- PLUS+1® GUIDE
- Proportional Valves
- Sensors
- Steering
- Transit Mixer Drives

Danfoss Power Solutions is a global manufacturer and supplier of high-quality hydraulic and electronic components. We specialize in providing state-of-the-art technology and solutions that excel in the harsh operating conditions of the mobile off-highway market. Building on our extensive applications expertise, we work closely with our customers to ensure exceptional performance for a broad range of off-highway vehicles.

We help OEMs around the world speed up system development, reduce costs and bring vehicles to market faster.

Danfoss – Your Strongest Partner in Mobile Hydraulics.

Go to www.powersolutions.danfoss.com for further product information.

Wherever off-highway vehicles are at work, so is Danfoss. We offer expert worldwide support for our customers, ensuring the best possible solutions for outstanding performance. And with an extensive network of Global Service Partners, we also provide comprehensive global service for all of our components.

Please contact the Danfoss Power Solution representative nearest you.

Comatrol

www.comatrol.com

Schwarzmueller-Inverter

www.schwarzmueller-inverter.com

Turolla

www.turollaocg.com

Hydro-Gear

www.hydro-gear.com

Daikin-Sauer-Danfoss

www.daikin-sauer-danfoss.com

Local address:

Danfoss Power Solutions (US) Company
2800 East 13th Street
Ames, IA 50010, USA
Phone: +1 515 239 6000

Danfoss Power Solutions GmbH & Co. OHG
Krokamp 35
D-24539 Neumünster, Germany
Phone: +49 4321 871 0

Danfoss Power Solutions ApS
Nordborgvej 81
DK-6430 Nordborg, Denmark
Phone: +45 7488 2222

Danfoss Power Solutions Trading (Shanghai) Co., Ltd.
Building #22, No. 1000 Jin Hai Rd
Jin Qiao, Pudong New District
Shanghai, China 201206
Phone: +86 21 3418 5200

Danfoss can accept no responsibility for possible errors in catalogues, brochures and other printed material. Danfoss reserves the right to alter its products without notice. This also applies to products already on order provided that such alterations can be made without changes being necessary in specifications already agreed. All trademarks in this material are property of the respective companies. Danfoss and the Danfoss logotype are trademarks of Danfoss A/S. All rights reserved.