

Technical Information

JS1000

Joystick Base



Revision history

Table of revisions

Date	Changed	Rev
May 2017	Minor layout correction	0703
April 2016	Updated to Engineering Tomorrow design	0702
Mar 2014	SAE J1939 Extended Joystick message transmission rate corrected; Danfoss layout-DITA CMS	HA
Nov 2010	PRO grip is only available in a top mount configuration; Supply voltage is 9 to 32 Vdc	GA
Mar 2010	Grip options; SAE J1939 CAN Message Specification; Electrical and Environmental Characteristics	FA
Mar 2010	Features; model code; dimension drawings	EA
Sep 2007	Standard CAN option information added; revised CAN Message Protocol section; and various specifications revised	DA
Dec 2005	Pro grip side switch color table; Repair section	CC
Nov 2005	Feature updates	BB
Jul 2005	First edition released Dec 2004; Jul 2005 Content revised	AA

Contents

Product overview

JS1000 Joystick Base.....	4
JS1000 Features and Options.....	4
JS1000 Theory of Operation.....	5

Product Configuration

JS1000 Product Configuration Model Code.....	6
JS1000 Base Model Code.....	6
JS1000 Grip Model Code	7

JS1000 CAN Messages and CAN Message Protocol

SAE J1939 CAN Option.....	11
SAE J1939 CAN message specification.....	11
SAE J1939 basic joystick message.....	11
SAE J1939 data field.....	11
Basic joystick message data field descriptions.....	11
SAE J1939 extended joystick message.....	15
SAE J1939 error (DM1) messages.....	16
PRO Grip Button and Proportional Roller CAN Naming Conventions.....	18
Joystick CANopen Object Dictionary.....	18

Product installation

Grip with Rocker Switch Dimensions and Mounting.....	19
Grip with Rocker Switch Connector Pin Assignments.....	19
Grip with Banana Switch Dimensions and Mounting.....	20
Grip with Banana Switch Connector Pin Assignments.....	20
Pro Grip Dimensions and Mounting	21
Pro Grip Connector Pin Assignments.....	21
Ball Grip Dimensions and Mounting.....	22
Ball Grip Connector Pin Assignments.....	22
Mating Connector Details.....	23
Mating Connector Deutsch® DTM06-6S.....	23
Machine wiring guidelines.....	23
Joystick safety critical functions.....	24

Specifications

Prof1 base mechanical specifications.....	25
Joystick Base Electrical.....	25
Joystick Base Environmental.....	25
Joysticks requiring repair.....	26

Product overview

JS1000 Joystick Base

Together with its family of associated grips, the JS1000 joystick base is a high-reliability operator input device for controlling mobile machine work functions. The joystick is available in single axis spring-centered and dual axis spring-centered configurations. Both versions are available with the standard ergonomic PRO grip, ball grip, grip with integral Hall effect sensor rocker switch, and grip with integrated hall effect banana switch. The JS1000 is ideally suited for low clearance and armrest mounting and it withstands the most punishing mobile machine applications.

High reliability is the product design goal for the JS1000. It is resistant to the extremes of temperature, shock, vibration and EMI/RFI typically found in mobile machine operating environments. The non-contact Hall effect technology and low part count eliminates many of the failure modes associated with traditional joystick technology. The JS1000 design has been tested to 10 million cycles per axis with no indication of bearing or boot wear and no degradation of electrical performance.

This technical manual describes the many features you can select to configure the right product for your application.

JS1000 with Ball Grip



JS1000 Features and Options

- Non-contacting Hall effect sensing
- Available redundant sensing per axis for CAN output configurations
- Single or dual axis
- X-Y axis guided
- Spring return-to-center
- Two centering spring options
- Operating life exceeding 10 million cycles per axis
- Three electrical output options:
 - CAN 2.0B, SAE J1939 message protocol
 - 5 to 4.5 Vdc (nominal)
 - CAN 2.0B, CANopen protocol
- IP-67 environmental rating above panel, grip dependent. IP-67 below panel with vent plug installed
- EMI/RFI protected to 100 V/m
- Stable null

Product overview

- Factory calibrated output range
- Low power consumption
- Multiple grip options:
 - Plain ball grip
 - Grip with rocker switch
 - Grip with banana switch
 - PRO grip

JS1000 Theory of Operation

The JS1000 base uses non-contacting Hall effect sensor technology to detect and transmit handle position. A spherical permanent magnet is attached to the base of the JS1000 shaft. This magnetic ball produces a magnetic field aligned with the Z-axis. Two programmable, temperature-compensated Hall effect sensors are positioned 90° from one another along the X and Y axes of the magnetic ball. They are aimed perpendicular to each other and the Z-axis. Movement of the joystick grip and the attached magnetic ball alters the magnetic field sensed by the Hall effect sensors, causing their electrical output to change. The output changes are proportional to changes in magnetic field caused by shaft movement. This electronic design yields a linear relationship between joystick shaft position and signal output, with no hysteresis and a stable null over the entire range of shaft displacement.

The programmable Hall effect sensors allow factory calibration of device null, gain, temperature coefficient and output voltage range. The joystick analog outputs are clamped to a nominal range of 0.5 Vdc to 4.5 Vdc. Any voltage outside that range can be assumed to be an invalid signal.

The two grip-with-switch options that are available with the JS1000 base feature a return to center Hall effect sensor rocker switch. The output range is nominally 23% to 77% of supply voltage. The output of the rocker switch can be used for state sensing (on-off) or for use as a proportional output.

Product Configuration

JS1000 Product Configuration Model Code

Use the JS1000 product configuration model code to specify particular features when ordering a JS1000 joystick. The model code begins with the product family name: JS1000. Fill in the remaining fields to configure the product with the desired features.

Product Configuration Model Code Example

J S 1 0 0 0 X Y A J 3 3 1 T P R O R 3 R L R Y Y N R N G N

Where:

XY	Multi-axis movement
A	Standard spring
J331	CAN output with SAE J1939 message protocol, 33 (hex) source address, 1000 counts output range
J33B	CAN output with SAE J1939 message protocol, 33 (hex) source address, 1000 counts output range, redundant sensor
TPRO	Top Mount, PRO Grip
R3RL	Right hand grip, 3 buttons, 1 Roller on the Left
RY	Right hand grip with Yellow side switch
YNRNG	Button 1 = Yellow Button 2 = None Button 3 = Red Button 4 = None Button 5 = Grey
N	No operator presence switch

JS1000 Base Model Code

JS1000 Product Configuration Model Code Example – Base Part - A, B, C, and D

A B C D E F G H J

J S 1 0 0 0 X Y A J 3 3 1 [] [] [] [] [] [] [] [] []

1 2 3 1 2

A Product Family

Code	Description
JS1000	JS1000 joystick base with Deutsch® connector, spring return-to-center

B Single or Dual Axis

Code	Description
XY	Dual axis function, forward and reverse with left and right, with guided axis (force increases in the corners)
NY	Single axis function, forward and reverse

C Center Return Spring

Code	Description
A	Standard spring
B	Heavy spring

Product Configuration

D1 Electrical Interface Options

Code	Description
J	CAN 2.0B, SAE J1939 message protocol
P	CAN 2.0B, CANopen protocol
S	Analog voltage output

D2 CAN Source Address*

Code	Description
NN	None—use with analog outputs when D1 = S
33	Source address = 0x 33
34	Source address = 0x 34
35	Source address = 0x 35
36	Source address = 0x 36

* Factory set CAN source addresses and node IDs can be changed using the PLUS+1® Service Tool.

D3 Joystick Output Type

Code	Description
N	None—use with analog output (when D1=S)
1	CAN full scale output = 1000 counts
B	CAN full scale output = 1000 counts, redundant sensor

JS1000 Grip Model Code

JS1000 Product Configuration Model Code Example – Base Part - E

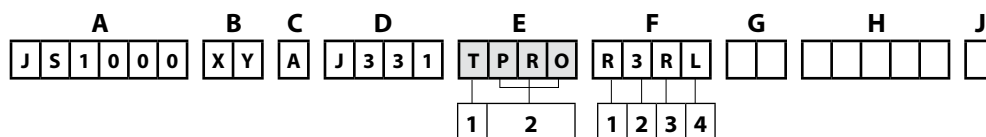

PRO grip is only available in a top mount configuration.

E1 Grip Mounting Options

Code	Description
B	Bottom mount (from below the panel, no boot retainer included, boot is captured between panel and housing) with IP-67 vent plug*
C	Bottom mount (from below the panel, no boot retainer included, boot is captured between panel and housing) without IP-67 vent plug*
T	Top mount (from above the panel, includes boot retainer for attaching boot to joystick housing) with IP-67 vent plug*
U	Top mount (from above the panel, includes boot retainer for attaching boot to joystick housing) without IP-67 vent plug*

*IP-67 vent plug is a Gor-Tex® moisture barrier. If the plug is not present, IP below the base is unrated.

Product Configuration

E2 Grip Mounting and Handle Options

Code	Description
PRO	PRO grip, CAN output. Complete section F, G, H, J
PR1	PRO grip, with no switch or proportional functions, CAN output
K01	Ball grip Do not complete F, G, H, J
LSW	Grip with rocker switch, 1.15 to 3.85 Vdc range (analog joystick) or On/Off switch (CAN joystick). Do not complete F, G, H, J
LSB	Grip with banana switch, 1.15 to 3.75 Vdc range (analog joystick) or On/Off switch (CAN joystick). Do not complete F, G, H, J
PSW	Grip with rocker switch CAN only. Proportional output representing voltage: 0 to 1000 CAN Counts = 0 to 5 Vdc. No fault checking available.
PSB	Grip with banana switch. CAN only. Proportional output representing voltage: 0 to 1000 CAN Counts = 0 to 5 Vdc. No fault checking available.

JS1000 Product Configuration Model Code Example – Base Part - F

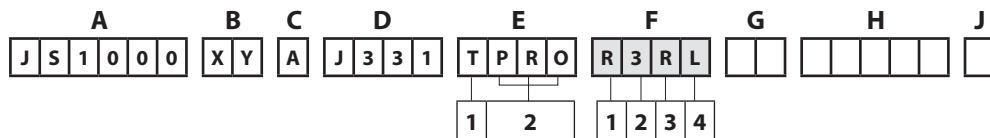

PRO grip available with CAN option only. Plain grip and grip-with-switch options are available with either analog or CAN output.

F1 PRO Grip Function Layout

Code	Description
R...	Right-handed grip
L...	Left-handed grip

F2 PRO Grip Function Layout

Code	Number of switches on the front plate
.0..	No switches
.1..	1 switch
.2..	2 switches
.3..	3 switches
.4..	4 switches
.5..	5 switches

F3 PRO grip function layout

Code	Type of proportional function
..R.	Roller or wheel, not sealed
..P.	Proportional grip function, sealed
..N.	None

Product Configuration

F4 PRO Grip Function Layout

Code	Position of proportional function
...N	No proportional function
...R	Vertical proportional function on the Right-hand side
...L	Vertical proportional function on the Left-hand side
...B	Horizontal proportional function on the Bottom
...D	Dual vertical proportional functions (on both the left and the right-hand sides)
...S	Stacked horizontal proportional functions as dual set on the top and the bottom
...T	Horizontal proportional function on Top

F Grip Function Layout Examples

Code	Description	Code	Description
R0NN	Right handed, 0 switches, No roller, No position	R2RL	Right handed, 2 switches, Roller, Left positioned
R1NN	Right handed, 1 switches, No roller, No position	R3RL	Right handed, 3 switches, Roller, Left positioned
R2NN	Right handed, 2 switches, No roller, No position	R0RB	Right handed, 0 switches, Roller, Bottom positioned
R3NN	Right handed, 3 switches, No roller, No position	R1RB	Right handed, 1 switches, Roller, Bottom positioned
R4NN	Right handed, 4 switches, No roller, No position	R2RB	Right handed, 2 switches, Roller, Bottom positioned
R5NN	Right handed, 5 switches, No roller, No position	R3RT	Right handed, 3 switches, Roller, Top positioned
R0RR	Right handed, 0 switches, Roller, Right positioned	R0RD	Right handed, 0 switches, 2 Roller, Dual positioned
R1RR	Right handed, 1 switches, Roller, Right positioned	R1RD	Right handed, 1 switches, 2 Roller, Dual positioned
R2RR	Right handed, 2 switches, Roller, Right positioned	R0RS	Right handed, 0 switches, 2 Roller, Stacked positioned
R3RR	Right handed, 3 switches, Roller, Right positioned	R1RS	Right handed, 1 switches, 2 Roller, Stacked positioned
R0RL	Right Handed, 0 switches, Roller, Left positioned	R2NR	Right handed, 2 switches, No roller, Right positioned
R1RL	Right Handed, 1 switches, Roller, Left positioned	R2NL	Right handed, 2 switches, No roller, Left positioned

JS1000 Product Configuration Model Code Example – Base Part - G, H, and J

A			B		C	D			E			F			G		H			J									
J	S	1	0	0	0	X	Y	A	J	3	3	1	T	P	R	O	R	3	R	L	R	Y	Y	N	R	R	N	G	N
																	1	2											

G1 PRO Grip Side Switch Orientation

Code	Description
R.	Right handed PRO Grip
L.	Left handed PRO Grip

G2 PRO Grip Side Switch Color

Code	Description
.R	Red side switch
.Y	Yellow side switch
.B	Black side switch
.G	Grey side switch
.N	No side switch

Product Configuration

H PRO Grip Front Plate Switch Color Selection Examples

Code	Description
NNNNN	No switches (diagram 0NN*)
RYBGR	Position 1 switch Red, position 2 switch Yellow, position 3 switch Black, position 4 switch Grey, position 5 switch Red (diagram 5NN*)
YYYYY	5 Yellow switches (diagram 5NN*)
RNNRB	Position 1 switch Red, No position 2 switch, No position 3 switch, position 4 switch Red, position 5 switch Black (diagram 3NN*)
YRNNN	Position 1 switch Yellow, Position 2 switch Red, No position 3 switch, No position 4 switch, No position 5 switch (diagram 2RL*)

* See *PRO Grip Button and Proportional Roller CAN Naming Conventions* on page 18. Number refers to button location on grip front panel. Select one color code for each switch.

J Operator Presence Switch Option (not available)

Code	Description
N	No: operator presence switch option not selected

JS1000 CAN Messages and CAN Message Protocol

SAE J1939 CAN Option

Joysticks with the SAE J1939 CAN output option, designated as model code CAN, broadcast two J1939 messages to communicate device information: Basic Joystick Message 1 (BJM1) and Extended Joystick Message 1 (EJM1).

SAE J1939 CAN message specification

SAE J1939 basic joystick message

This joystick uses the SAE J1939 basic joystick message to transfer information about the position on the X and Y axes of a joystick, the state of switches on the joystick grip, and the state of external digital inputs.

Basic joystick message structure

Basic message number	Priority	Base parameter Group number (PGN)		Protocol Data Unit (PDU) format		PDU specific		Source address		Data field
		Dec	hex	Dec	hex	Dec	hex	Dec	hex	
1	3	64982	FDD6	253	FD	214	D6	*	*	8 bytes

* Depends on position specified in master model code. This joystick does not support SAE J1939 dynamic addressing, since the joystick source addresses are hard-coded (static). However, this joystick is compliant with SAE J1939 address claiming protocol (in the unlikely event another node on the SAE J1939 bus claims an identical source address to this joystick, this joystick may cease communication on the bus, depending on the message priority of the other node).

Message transmission rate: 20 ms

CAN bus baud rate: 250kbps

CANopen bus baud rate selectable, default: 125kbps

The resulting SAE J1939 basic joystick message PGN on the CAN bus is: 0xCFDD6 

SAE J1939 data field

The data field contains the joystick's output information. SAE J1939 data fields contain 8 bytes of data.

Information in the data field

Byte#	0								1								2 and so on							
Bit#	1	2	3	4	5	6	7	8	1	2	3	4	5	6	7	8	1	2	3	4	5	6	7	8

Basic joystick message data field descriptions

Basic joystick message parameters and data field locations

Start position (byte/bit)	Length (bits)	Parameter name
0/1	2	Joystick X-axis neutral position status
0/3	2	Joystick X-axis lever left negative position status
0/5	2	Joystick X-axis lever right positive position status
0/7 through 1/1-8	10	Joystick X-axis position (Byte 0 Bit 7 is LSB*. Byte 1 Bit 8 is MSB**)
2/1	2	Joystick Y-axis neutral position status

JS1000 CAN Messages and CAN Message Protocol

Basic joystick message parameters and data field locations (continued)

Start position (byte/bit)	Length (bits)	Parameter name
2/3	2	Joystick Y-axis lever back negative position
2/5	2	Joystick Y-axis lever forward positive position
2/7 through 3/1-8	10	Joystick Y-axis position (Byte 2 Bit 7 is LSB*. Byte 3 Bit 8 is MSB**)
4/5	2	Joystick Y-axis detent position status
4/7	2	Joystick X-axis detent position status
5/1	2	Grip button 4 pressed status
5/3	2	Grip button 3 pressed status
5/5	2	Grip button 2 pressed status
5/7	2	Grip button 1 pressed status
6/1	2	Grip button 8 pressed status
6/3	2	Grip button 7 pressed status
6/5	2	Grip button 6 pressed status
6/7	2	Grip button 5 pressed status
7/1	2	Grip button 12 pressed status
7/3	2	Grip button 11 pressed status
7/5	2	Grip button 10 presses status
7/7	2	Grip button 9 pressed status

*Least Significant Bit **Most Significant Bit

Button naming convention: Refer to the illustrated naming conventions, for button and proportional input definitions.

Data field examples

Byte	0							
Bit	8	7	6	5	4	3	2	1
	The 2 LSB* of X-axis position		X-axis lever right positive status		X-axis lever left negative position status		X-axis neutral position status	

*Least Significant Bit

Byte	1							
Bit	8	7	6	5	4	3	2	1
	MSB** X-axis position							

**Most Significant Bit

Byte	2							
Bit	8	7	6	5	4	3	2	1
	The 2 LSB* of Y-axis position status		X-axis lever forward positive status		Y-axis lever back negative position status		Y-axis neutral position status	

*Least Significant Bit

Joystick X-axis neutral position status:

JS1000 CAN Messages and CAN Message Protocol

Reports when the current joystick position is in the neutral position for the X-axis of travel.

Information in the data field

Bit status	Remarks
00	Not in neutral position
01	In neutral position
10	Error indicator
11	Not available

Joystick X-axis handle left negative position status:

Reports when the current joystick position is on the negative travel side (back, left, counterclockwise, down) relative to the neutral position for the X-axis.

Information in the Data Field

Bit status	Remarks
00	Not on negative side of neutral
01	On negative side of neutral
10	Error indicator
11	Not available

Joystick X-axis handle right positive position status:

Reports when the current joystick position is on the positive travel side (forward, right, clockwise, up) relative to the neutral position for the X-axis.

Information in the data field

Bit status	Remarks
00	Not on positive side of neutral
01	On positive side of neutral
10	Error indicator
11	Not available

Joystick X-axis position status:

This is the position of the joystick in the relative motion of travel from the neutral position. The position value of 0 is always neutral. The output range of the joystick handle at the end of travel is factory set according to the option specified in the electrical interface options section of the master model code.

The master model code specifies that the full-scale output at the end of each linear zone will be 1000 counts.

Warning

Potential uncommanded machine movement. Per the SAE J1939-71 standard, if the JS1000 joystick internal diagnostics detect a shaft position measurement error, the joystick output will be set to a value of 1022 counts regardless of shaft position. Ensure application software recognizes this error condition to avoid the possibility of unintended machine motion.

JS1000 CAN Messages and CAN Message Protocol

Warning

Potential uncommanded machine movement. Per the SAE J1939-71 standard, if a specific joystick axis is not available, the basic joystick message for the unavailable axis will indicate an output value of 1023 counts. Ensure application software recognizes this condition to avoid the possibility of unintended machine motion.

Joystick Y-axis neutral position status:

Reports when the current joystick position is in the neutral position for the Y-axis of travel.

Information in the data field

Bit status	Remarks
00	Not in neutral position
01	In neutral position
10	Error indicator
11	Not available

Joystick Y-axis handle back negative position status:

Reports when the current joystick position is on the negative travel side (back, left, counterclockwise, down) relative to the neutral position for the Y-axis.

Information in the data field

Bit status	Remarks
00	Not on negative side of neutral
01	On negative side of neutral
10	Error indicator
11	Not available

Joystick Y-axis handle forward positive position status:

Reports when the current joystick position is on the positive travel side (forward, right, clockwise, up) relative to the neutral position for the Y-axis.

Information in the data field

Bit status	Remarks
00	Not on positive side of neutral
01	On positive side of neutral
10	Error indicator
11	Not available

Joystick Y-axis position status:

This is the position of the joystick in the relative motion of travel from the neutral position. The position value of 0 is always neutral. The output range of the joystick handle at the end of travel is factory set according to the option specified in the electrical interface options section of the master model code.

[The master model code specifies that the full-scale output at the end of each linear zone is 1000 counts.](#)

JS1000 CAN Messages and CAN Message Protocol

Warning

Potential uncommanded machine movement. Per the SAE J1939-71 standard, if the joystick internal diagnostics detect a shaft position measurement error, the joystick output will be set to a value of 1022 counts regardless of shaft position. Ensure application software recognizes this error condition to avoid the possibility of unintended machine motion.

Warning

Potential uncommanded machine movement. Per the SAE J1939-71 standard, if a specific joystick axis is not available, the basic joystick message for the unavailable axis will indicate an output value of 1023 counts. Ensure application software recognizes this condition to avoid the possibility of unintended machine motion.

Joystick button 1-8 pressed status

Bit status	Remarks
00	Button not pressed
01	Button pressed
10	Error indicator
11	Not available (no button installed)

SAE J1939 extended joystick message

This joystick uses the SAE J1939 extended joystick message to transfer information about the measured status of two additional proportional input functions on the joystick grip. The joystick base X and Y-axis information is available in the basic joystick message. The extended joystick message structure is as follows:

Extended joystick message structure

Extended message number	Priority	Base PGN		PDU format		PDU specific		Source address		Data field
		Dec	hex	Dec	hex	Dec	hex	Dec	hex	
1	3	64983	FDD7	253	FD	215	D7	*	*	8 bytes

* Depends on position specified in master model code. This joystick does not support SAE J1939 dynamic addressing, since the joystick source addresses are hard-coded (static). However, this joystick is compliant with SAE J1939 address claiming protocol (in the unlikely event another node on the SAE J1939 bus claims an identical source address to this joystick, this joystick may cease communication on the bus, depending on the message priority of the other node).

Message transmission rate: 20 ms

CAN bus baud rate: 250kbps

The resulting SAE J1939 basic joystick message PGN on the CAN bus is: 0xCFDD7

* = joystick source address (hex)

Extended joystick message parameters and data field locations

Start position (Byte/Bit)	Length (Bits)	Parameter name
1/1	2	Grip X-axis neutral position status
1/3	2	Grip X-axis lever left negative position status

JS1000 CAN Messages and CAN Message Protocol

Extended joystick message parameters and data field locations (continued)

Start position (Byte/Bit)	Length (Bits)	Parameter name
1/5	2	Grip X-axis lever right positive position status
1/7 through 2/1-8	10	Grip X-axis position
3/1	2	Grip Y-axis neutral position status
3/3	2	Grip Y-axis lever back negative position
3/5	2	Grip Y-axis lever forward positive position
3/7 through 4/1-8	10	Grip Y-axis position
7/5	2	Grip Y-axis detent position status-not available
7/7	2	Grip X-axis detent position status-not available

Data field descriptions and output ranges for extended joystick messages are similar to those for base X and Y-axis basic joystick messages.

PRO grip proportional input naming convention

Proportional input location	Extended joystick message designation
Horizontal orientation, top	X-axis
Horizontal orientation, bottom	Y-axis
Vertical orientation, left side	X-axis
Vertical orientation, right side	Y-axis

Grip-with-switch naming convention: The top switch is designated as the grip X-axis in the SAE J1939 extended joystick message. Moving the switch in either direction from null results in an immediate CAN output of 1000 counts.

SAE J1939 error (DM1) messages

SAE J1939 DM1 error messages are supported by JS1000 software.

See the tables below for Suspect Parameter Number (SPN) and Failure Mode Identifier (FMI) information.

Failure: Voltage too high

Message	Axis	SPN	FMI
BJM1	X	2660	3
BJM1	Y	2661	3
BJM1	Grip X	2662	3
BJM1	Grip Y	2663	3
BJM1	Grip Theta	2664	3

Failure: Voltage too low

Message	Axis	SPN	FMI
BJM1	X	2660	4
BJM1	Y	2661	4
BJM1	Grip X	2662	4
BJM1	Grip Y	2663	4
BJM1	Grip Theta	2664	4

JS1000 CAN Messages and CAN Message Protocol

Failure: Input not calibrated

Message	Axis	SPN	FMI
BJM1	X	2660	13
BJM1	Y	2661	13
BJM1	Grip X	2662	13
BJM1	Grip Y	2663	13
BJM1	Grip Theta	2664	13

Failure: Redundant input failure

Message	Axis	SPN	FMI
BJM1	X	2660	14
BJM1	Y	2661	14
BJM1	Grip X	2662	14
BJM1	Grip Y	2663	14
BJM1	Grip Theta	2664	14

This joystick does not support SAE J1939 dynamic addressing, since the joystick source addresses are hard-coded (static). However, this joystick is compliant with SAE J1939 address claiming protocol (in the unlikely event another node on the SAE J1939 bus claims an identical source address to this joystick, this joystick may cease communication on the bus, depending on the message priority of the other node).

JS1000 CAN Messages and CAN Message Protocol

PRO Grip Button and Proportional Roller CAN Naming Conventions

Illustrated Naming Conventions

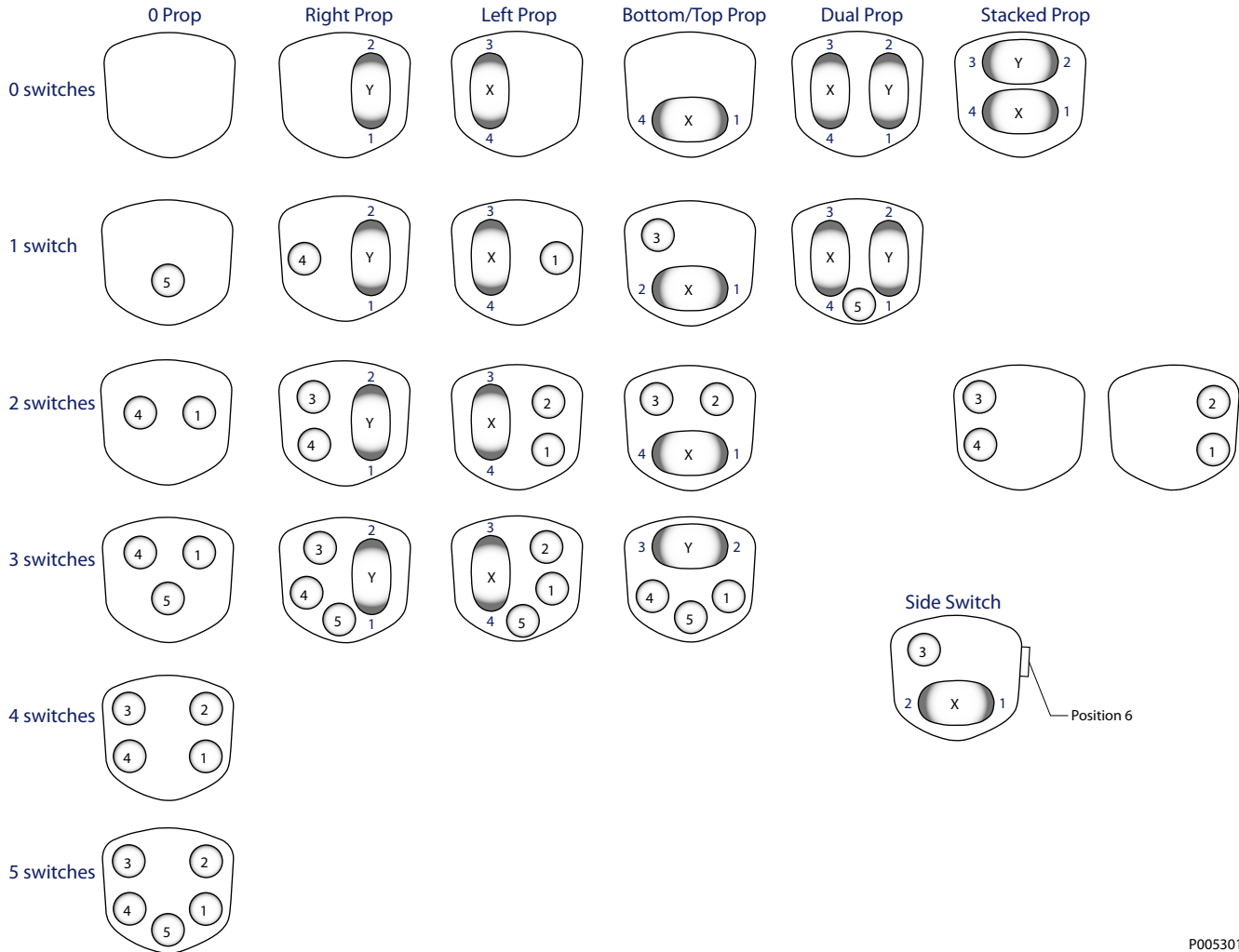

P005301F

Joystick CANopen Object Dictionary

CANopen Object Dictionary is on line at <http://www.powersolutions.danfoss.com>
 Access the dictionary in PDF format under Joysticks, CANopen EDS.

Product installation

Grip with Rocker Switch Dimensions and Mounting

Millimeters [Inches]

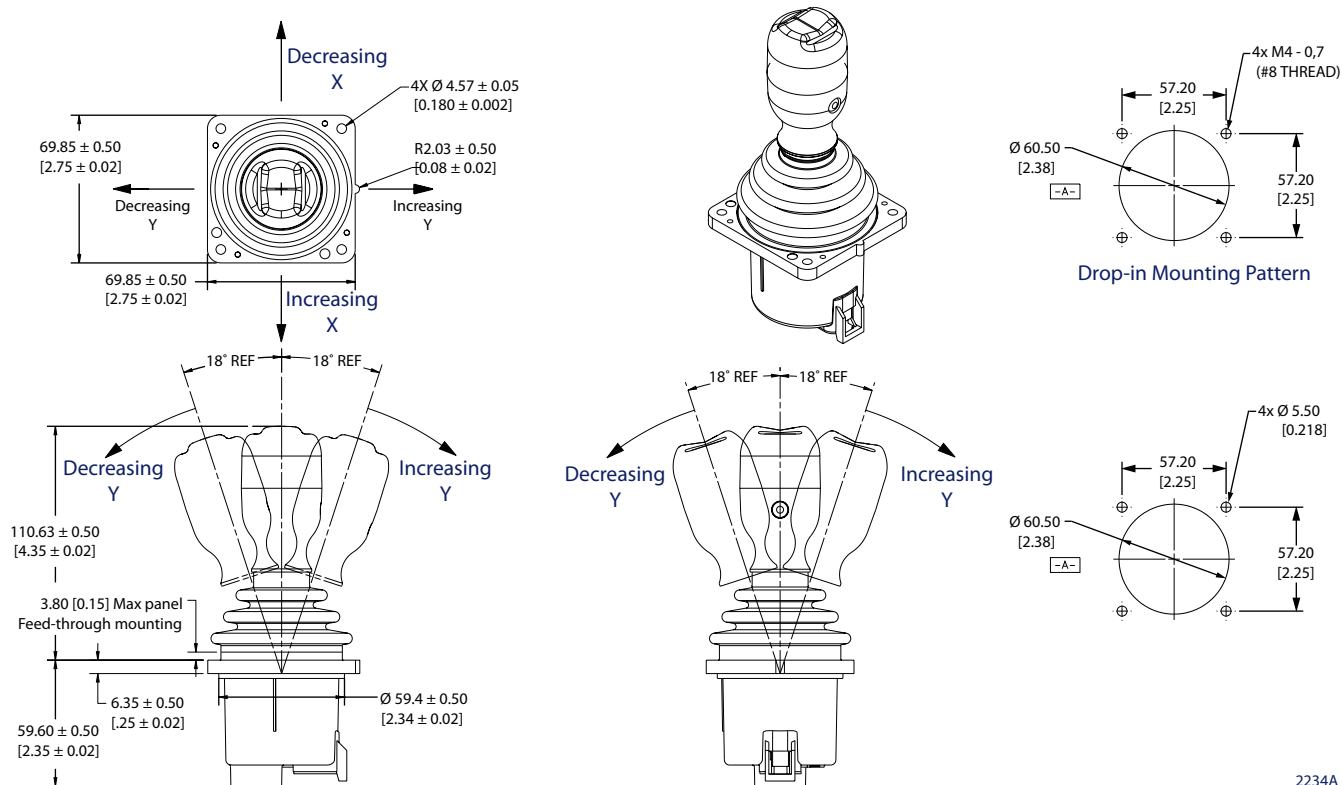

2234A

Grip with Rocker Switch Connector Pin Assignments

6 Pin Connector

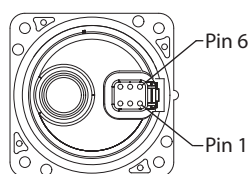

2242

Grip with Rocker Switch Connector Pin Assignments

Pin	Analog option	CAN option
1	Ground -	Ground
2	5 Vdc Power +	Power
3	X output signal	CAN +
4	Y output signal	CAN -
5	Rocker switch	CAN Shield
6	No connection	No connection

Product installation

Grip with Banana Switch Dimensions and Mounting

Millimeters [Inches]

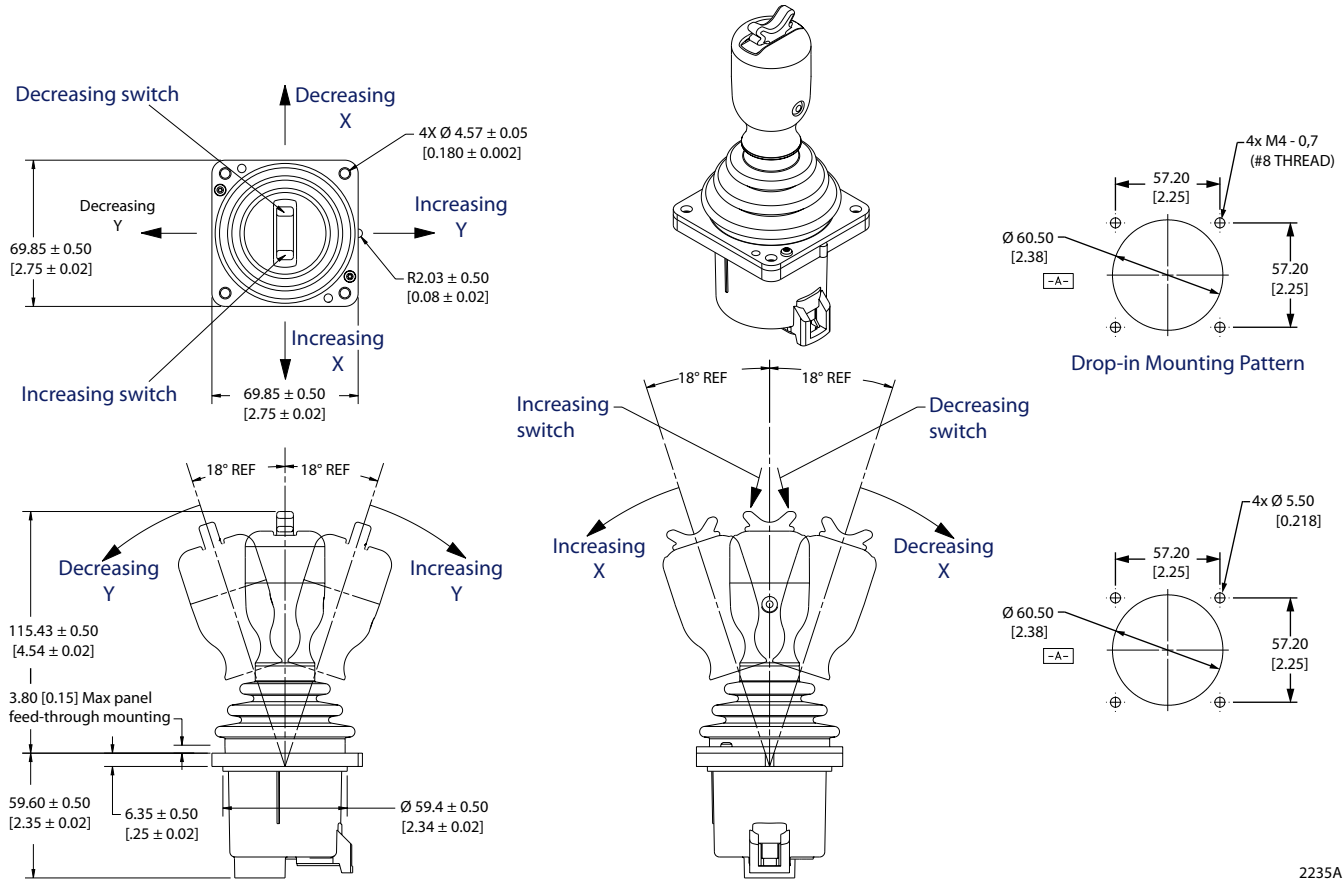

2235A

Grip with Banana Switch Connector Pin Assignments

6 Pin Connector

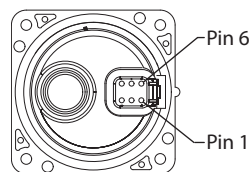

2242

Grip with Banana Switch Connector Pin Assignments

Pin	Analog option	CAN option
1	Ground -	Ground
2	5 Vdc Power +	Power
3	X output signal	CAN +
4	Y output signal	CAN -
5	Rocker switch	CAN Shield
6	No connection	No connection

Product installation

Pro Grip Dimensions and Mounting

Millimeters [Inches]

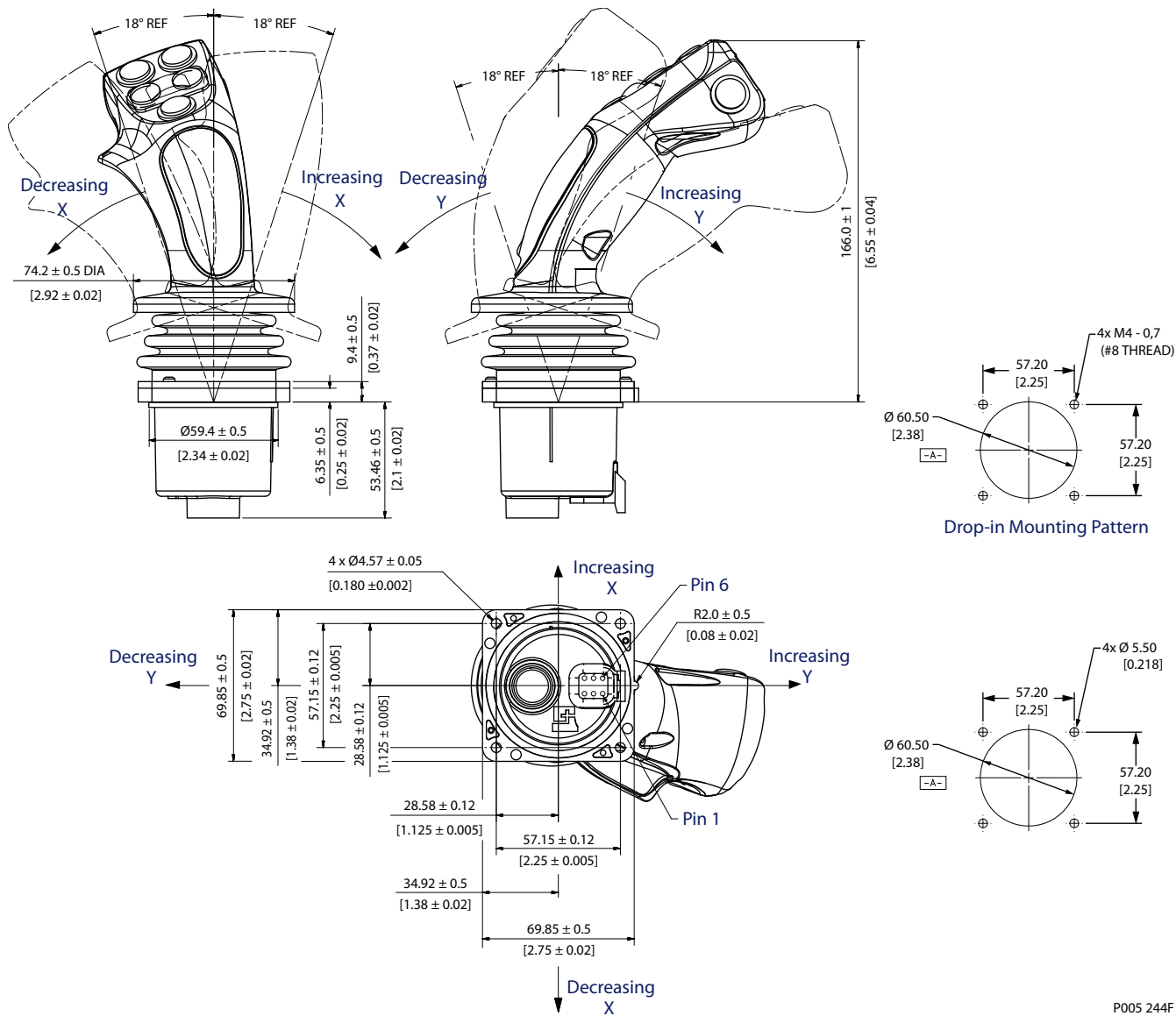

P005 244F

Pro Grip Connector Pin Assignments

6 Pin Connector

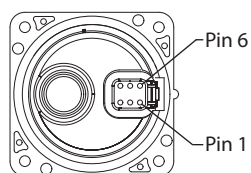

2242

Product installation

Pro Grip Connector Pin Assignments

Pin	CAN option
1	Ground
2	Power
3	CAN high
4	CAN low
5	CAN shield
6	No connection

Ball Grip Dimensions and Mounting

Millimeters [Inches]

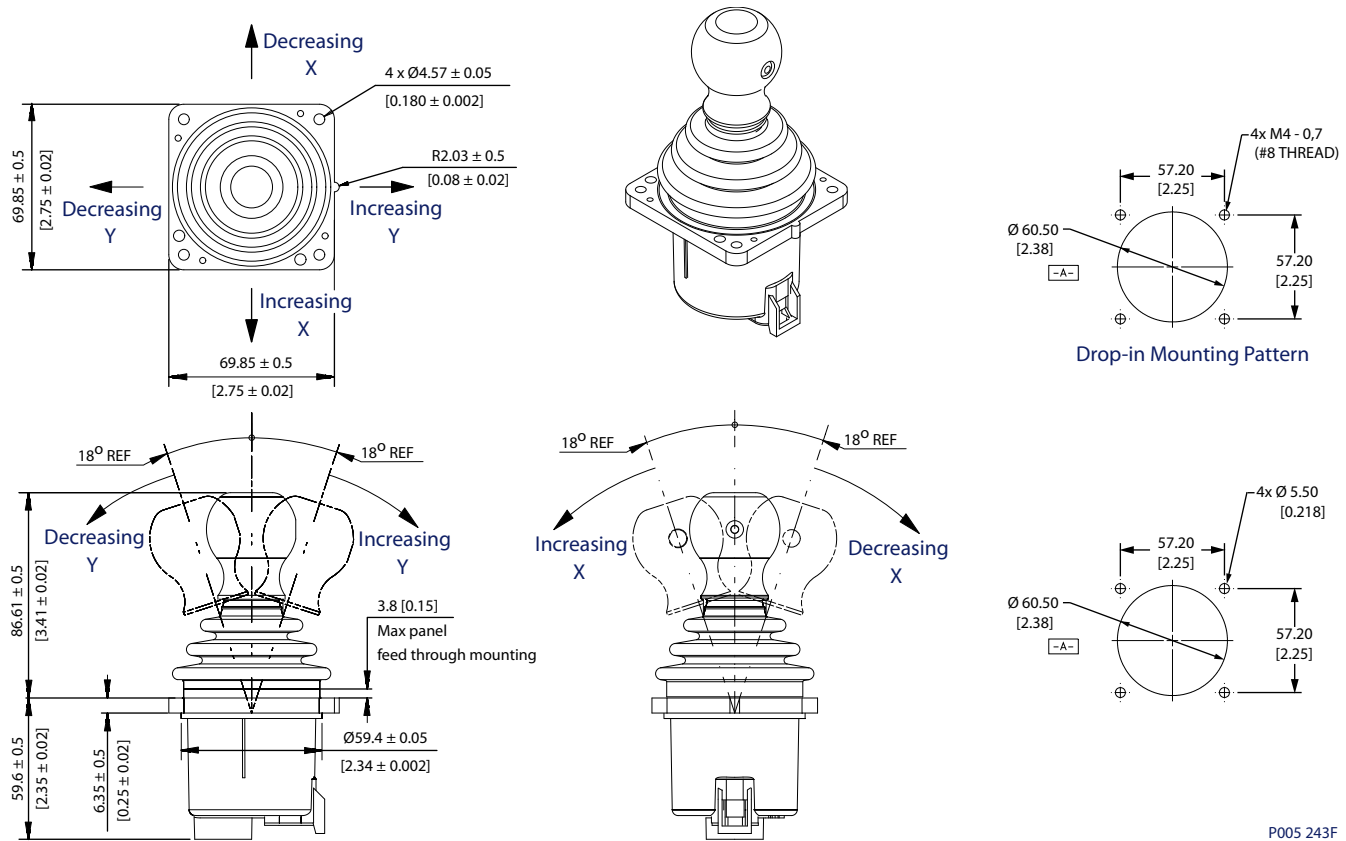

P005 243F

Ball Grip Connector Pin Assignments

6 Pin Connector

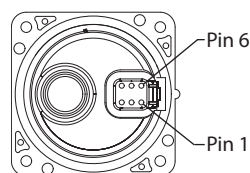

2242

Product installation

Ball Grip Connector Pin Assignments

Pin	Analog option	CAN option
1	Ground -	Ground
2	5 Vdc Power +	Power
3	X output signal	CAN +
4	Y output signal	CAN -
5	No connection	CAN Shield
6	No connection	No connection

Mating Connector Details

Mating Connector Deutsch® DTM06-6S

Danfoss provides mating connector kits (bag assemblies) for JS1000 joysticks. The bag assembly contains loose parts you must assemble. The connector with ribbon cable features a fully assembled connector with an unterminated wire harness.

Mating Connector Assemblies

Type	Danfoss ordering number
Connector bag assembly	10101551
Connector with 400 mm [15.75 in] Wire Harness	10101557

Machine wiring guidelines

- Protect wires from mechanical abuse, run wires in flexible metal or plastic conduits.
- Use 85° C (185° F) wire with abrasion resistant insulation and 105° C (221° F) wire should be considered near hot surfaces.
- Use a wire size that is appropriate for the module connector.
- Separate high current wires such as solenoids, lights, alternators or fuel pumps from sensor and other noise-sensitive input wires.
- Run wires along the inside of, or close to, metal machine surfaces where possible, this simulates a shield which will minimize the effects of EMI/RFI radiation.
- Do not run wires near sharp metal corners, consider running wires through a grommet when rounding a corner.
- Do not run wires near hot machine members.
- Provide strain relief for all wires.
- Avoid running wires near moving or vibrating components.
- Avoid long, unsupported wire spans.
- Ground electronic modules to a dedicated conductor of sufficient size that is connected to the battery (-).
- Power the sensors and valve drive circuits by their dedicated wired power sources and ground returns.
- Twist sensor lines about one turn every 10 cm (4 in).
- Use wire harness anchors that will allow wires to float with respect to the machine rather than rigid anchors.

Product installation

Joystick safety critical functions

For a system to operate safely it must be able to differentiate between commanded and uncommanded inputs. Take steps to detect and manage joystick and system failures that may cause an erroneous output.

For safety critical functions Danfoss recommends you use an independent momentary action system enable switch. You can incorporate this switch into the joystick as an operator presence switch or can be a separate foot or hand operated momentary switch. Disable all joystick functions that the joystick controls when this switch is released.

Ensure the control system looks for the appropriate system enable switch input before the joystick is displaced from its neutral position. Enable functions only after receiving this input.

Applications using CAN joysticks should continuously monitor for the presence of the CAN messages on periodic basis. Messages are to be checked frequently enough for the system or operator to react if the CAN messages lose priority or are no longer received.

Specifications

Prof1 base mechanical specifications

Base mechanical

Operating life	10 million cycles per axis
Handle travel	On-axis: 18° Corners: 24.7°
Spring centering forces	Standard Spring: Breakout: 12 N [2.69 lbf] / On axis end of travel: 18 N [4.0 lbf] / At end of stroke at corners: 20 N [4.49 lbf] Heavy Spring: Breakout: 20 N [4.49 lbf] / On-axis end of travel: 29 N [6.51 lbf] / At end of stroke at corners 32 N [7.19 lbf]
Shaft forces	Force to bend shaft: 97.8 N.m [866 lbf.in] at 55 mm [2.165 in] Maximum shaft torque: 25.42 N.m [255 lbf.in] Maximum downward force: > 4.45 kN [1000 lbf]
Weight (base without grip)	0.38 kg [0.838 lbf]

Joystick Base Electrical

Analog Option

Supply voltage	5.0 ± 0.5 Vdc
Maximum current draw	Base with no grip: 15 mA Base with rocker switch grip: 25 mA
Output parameters, joystick base	Null shift over rated temperature: 2% of supply voltage Span shift over rated temperature: 2% of supply voltage Linearity: 1% maximum deviation of voltage vs. shaft angle Output at maximum displacement: 92% ± 4% of supply voltage Output at Null: 50% ± 2% of supply voltage Output at minimum displacement: 8% ± 4% of supply voltage Maximum output current for each axis channel: 2 mA Maximum output current for each switch: 2 mA
Output parameters, rocker switch	Output at maximum displacement: 77% ± 7% of supply voltage Output at Null: 50% ± 8% of supply voltage Output at minimum displacement: 23% ± 7% of supply voltage

CAN Option

Supports CAN 2.0B with SAE J1939 message protocol	
Supply voltage	9 to 32 Vdc
Maximum current draw	150 mA—base with PRO grip

Joystick Base Environmental

Environmental Characteristics

Base operating temperature	-40°C to +80°C [-40°F to +175°F]
Base storage temperature	-55°C to +85°C [-67°F to +180°F]
Ingress protection rating	
Above panel (Depends on grip and base options):	IP-67
Below panel (Depends on grip and base options):	IP-67
PRO grip:	IP-43
PRO grip with proportional roller function):	IP-40

Specifications

Environmental Characteristics (continued)

EMI/RFI rating	100 V/m
Vibration	Meets IEC 60068-2-64
Shock	Meets IEC 60068-2-27 test Ea

Joysticks requiring repair

Return joystick along with information describing the product fault to:

MPS CQAR Administrator

Danfoss Power Solutions

3500 Annapolis Lane North,

Minneapolis, Minnesota 55447-5312, USA

Products we offer:

- Bent Axis Motors
- Closed Circuit Axial Piston Pumps and Motors
- Displays
- Electrohydraulic Power Steering
- Electrohydraulics
- Hydraulic Power Steering
- Integrated Systems
- Joysticks and Control Handles
- Microcontrollers and Software
- Open Circuit Axial Piston Pumps
- Orbital Motors
- PLUS+1® GUIDE
- Proportional Valves
- Sensors
- Steering
- Transit Mixer Drives

Danfoss Power Solutions is a global manufacturer and supplier of high-quality hydraulic and electronic components. We specialize in providing state-of-the-art technology and solutions that excel in the harsh operating conditions of the mobile off-highway market. Building on our extensive applications expertise, we work closely with our customers to ensure exceptional performance for a broad range of off-highway vehicles.

We help OEMs around the world speed up system development, reduce costs and bring vehicles to market faster.

Danfoss – Your Strongest Partner in Mobile Hydraulics.

Go to www.powersolutions.danfoss.com for further product information.

Wherever off-highway vehicles are at work, so is Danfoss. We offer expert worldwide support for our customers, ensuring the best possible solutions for outstanding performance. And with an extensive network of Global Service Partners, we also provide comprehensive global service for all of our components.

Please contact the Danfoss Power Solution representative nearest you.

Comatrol

www.comatrol.com

Turolla

www.turollaocg.com

Hydro-Gear

www.hydro-gear.com

Daikin-Sauer-Danfoss

www.daikin-sauer-danfoss.com

Local address:

**Danfoss
Power Solutions (US) Company**
2800 East 13th Street
Ames, IA 50010, USA
Phone: +1 515 239 6000

**Danfoss
Power Solutions GmbH & Co. OHG**
Krokamp 35
D-24539 Neumünster, Germany
Phone: +49 4321 871 0

**Danfoss
Power Solutions ApS**
Nordborgvej 81
DK-6430 Nordborg, Denmark
Phone: +45 7488 2222

**Danfoss
Power Solutions Trading
(Shanghai) Co., Ltd.**
Building #22, No. 1000 Jin Hai Rd
Jin Qiao, Pudong New District
Shanghai, China 201206
Phone: +86 21 3418 5200

Danfoss can accept no responsibility for possible errors in catalogues, brochures and other printed material. Danfoss reserves the right to alter its products without notice. This also applies to products already on order provided that such alterations can be made without changes being necessary in specifications already agreed. All trademarks in this material are property of the respective companies. Danfoss and the Danfoss logotype are trademarks of Danfoss A/S. All rights reserved.