

Technical Information

# Orbital Motors

TMT, TMTU, TMTW, TMT FL and TMTW FL



**Revision history***Table of revisions*

<b>Date</b>	<b>Changed</b>	<b>Rev</b>
March 2016	Engineering Tomorrow	0402
November 2014	Converted to Danfoss layout - DITA CMS	DA
July 2008		CA
January 2004		BA

**Contents**

**A wide range of Orbital Motors**

Characteristic, features and application areas of Orbital Motors.....	4
Characteristic features of Danfoss Orbital Motors.....	4
Technical features of Danfoss Orbital Motor.....	4
Survey of literature with technical data on Danfoss Orbital Motors.....	5

**Data survey**

Speed and torque.....	6
-----------------------	---

**Versions**

Versions and code numbers.....	7
Features available (options).....	8
Code numbers.....	9

**Technical data**

Technical data for TMT, TMTU, TMTW and TMT FL.....	10
Technical data for brake motor TMT FL and TMTW FL.....	11
Maximal permissible shaft seal pressure.....	11
Pressure drop in motor.....	12
Oil flow in drain line.....	12
Direction of shaft rotation.....	13
Permissible radial shaft load.....	13
Permissible shaft load for TMT and TMT FL.....	14
Permissible radial shaft load for TMTW.....	15
Permissible radial shaft load for TMTW FL.....	16

**Function diagrams**

Function diagrams.....	17
------------------------	----

**Shaft version**

TMT shaft, European versions.....	20
TMT shaft, US versions.....	21

**Technical data**

Port thread versions.....	23
---------------------------	----

**Dimensions – attached component**

Dimensions of the attached component for TMTU (bearing less).....	24
Internal spline data for the component to be attached.....	24

**Dimensions**

Drain connection on TMTU or attached component.....	26
Blank shaft.....	26
TMT dimensions.....	27
TMTU dimensions.....	32
TMT FL dimensions.....	35
TMTW dimensions.....	42
TMTW FL dimensions.....	45

**Weight of motors**

Weight of TMT, TMTU, TMTW, TMT FL and TMTW FL orbital motors.....	47
---	----

## A wide range of Orbital Motors

### Characteristic, features and application areas of Orbital Motors

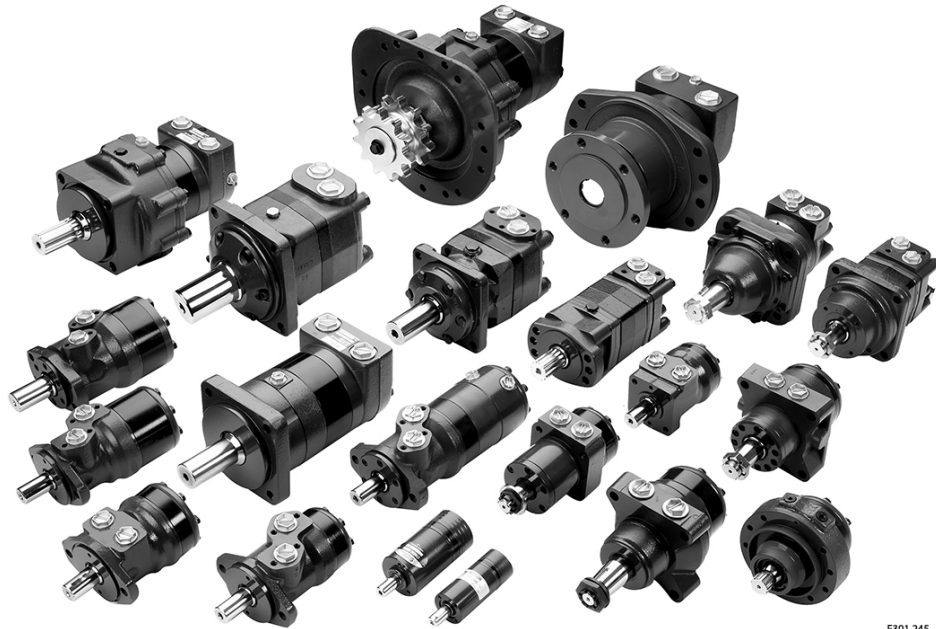

F301 245

Danfoss is a world leader within production of low speed orbital motors with high torque. We can offer more than 3,000 different orbital motors, categorised in types, variants and sizes (including different shaft versions).

The motors vary in size (rated displacement) from 8 cm<sup>3</sup> [0.50 in<sup>3</sup>] to 800 cm<sup>3</sup> [48.9 in<sup>3</sup>] per revolution.

Speeds range up to approximate 2,500 min<sup>-1</sup> (rpm) for the smallest type and up to approximate 600 min<sup>-1</sup> (rpm) for the largest type.

Maximum operating torques vary from 13 N·m [115 lbf·in] to 2,700 N·m [24,000 lbf·in] (peak) and maximum outputs are from 2.0 kW [2.7 hp] to 70 kW [95 hp].

### Characteristic features of Danfoss Orbital Motors

- Smooth running over the entire speed range
- Constant operating torque over a wide speed range
- High starting torque
- High return pressure without the use of drain line (High pressure shaft seal)
- High efficiency
- Long life under extreme operating conditions
- Robust and compact design
- High radial and axial bearing capacity
- For applications in both open and closed loop hydraulic systems
- Suitable for a wide variety of hydraulics fluids

### Technical features of Danfoss Orbital Motor

The programme is characterised by technical features appealing to a large number of applications and a part of the programme is characterised by motors that can be adapted to a given application. Adaptions comprise the following variants among others:

- Motors with corrosion resistant parts

**A wide range of Orbital Motors**

- Wheel motors with recessed mounting flange
- OMP, OMR- motors with needle bearing
- OMR motor in low leakage version
- OMR motors in a super low leakage version
- Short motors without bearings
- Ultra short motors
- Motors with integrated positive holding brake
- Motors with integrated negative holding brake
- Motors with integrated flushing valve
- Motors with speed sensor
- Motors with tacho connection
- All motors are available with black finish paint

**Survey of literature with technical data on Danfoss Orbital Motors**

Detailed data on all Danfoss Orbital Motors can be found in our motor catalogue, which is divided into more individual subcatalogues:

- General information on Danfoss Orbital Motors: function, use, selection of orbital motor, hydraulic systems, etc.
- Technical data on small motors: OML and OMM
- Technical data on medium sized motors: OMP, OMR, OMH
- Technical data on medium sized motors: DH and DS
- Technical data on medium sized motors: OMEW
- Technical data on medium sized motors: VMP
- Technical data on medium sized motors: VMR
- Technical data on large motors: OMS, OMT and OMV
- Technical data on large motors: TMK
- Technical data on large motors: TMT
- Technical data on large motors: TMTHW
- Technical data on large motors: TMVW

A general survey brochure on Danfoss Orbital Motors gives a quick motor reference based on power, torque, speed and capabilities.

Data survey

Speed and torque

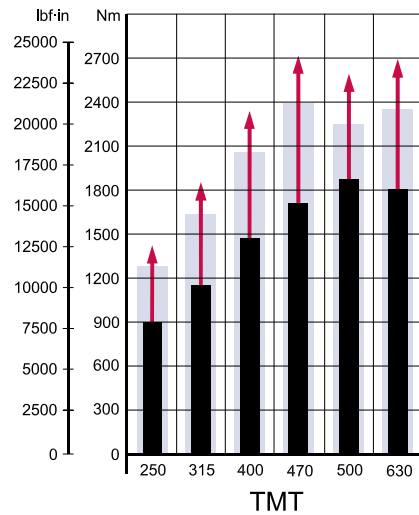
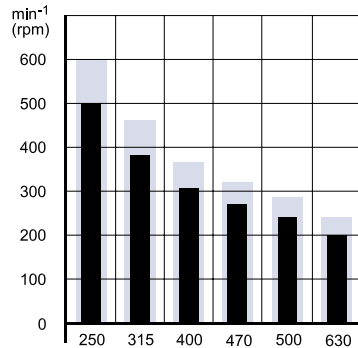

TMT

↑ (Red Arrow) □ (Light Blue) ■ (Black)

151-1975.10

Peak values, Intermittend values, Continuous values

The bar diagrams above are useful for a quick selection of relevant motor size for the application. The final motor size can be determined by using the function diagram for each motor size.

- TMT can be found in [Function diagrams](#) on page 17

The function diagrams are based on actual tests on a representative number of motors from our production. The diagrams apply to a return pressure between 5 and 10 bar [75 and 150 psi] when using mineral based hydraulic oil with a viscosity of 35 mm<sup>2</sup>/s [165 SUS] and a temperature of 50°C [120°F]. For further explanation concerning how to read and use the function diagrams, please consult the paragraph "Selection of motor size" in the *Technical Information General - 520L0232*.

**Versions**
**Versions and code numbers**
*TMT versions*

Mounting flange	4-Bolt								
Spigot diameter	Ø 160 mm	Ø 125 mm	Ø 5 in	Ø 160 mm	Ø 125 mm	Ø 5 in	Ø 160 mm	Ø 125 mm	Ø 5 in
Bolt circle diameter (BC)	Ø 200 mm	Ø 160 mm	Ø 6.37 in	Ø 200 mm	Ø 160 mm	Ø 6.37 in	Ø 200 mm	Ø 160 mm	Ø 6.37 in
Shaft	Cyl 40 mm	Cyl 40 mm	Cyl 1.5 in	Splined 1.5 in	Splined 1.5 in	Splined 1.5 in	Tap. 45 mm	Tap. 45 mm	Tap. 1 3/4 in
Port size	G 3/4	G 3/4	1 1/16 - 12 UN	G 3/4	G 3/4	1 1/16 - 12 UN	G 3/4	G 3/4	1 1/16 - 12 UN
European version	●	●		●	●		●	●	
US version			●			●			●
Side port version	●	●	●	●	●	●	●	●	●
Standard shaft seal	●	●	●	●	●	●	●	●	●
Drain connection	Yes	Yes	Yes	Yes	Yes	Yes	Yes	Yes	Yes
Check valve	No	No	No	No	No	No	No	No	No
<b>Code numbers</b>									
TMT 250	151Z3010	151Z3016	151Z3060	151Z3020	151Z3026	151Z3070	151Z3030	151Z3036	151Z3080
TMT 315	151Z3011	151Z3017	151Z3061	151Z3021	151Z3027	151Z3071	151Z3031	151Z3037	151Z3081
TMT 400	151Z3012	151Z3018	151Z3062	151Z3022	151Z3028	151Z3072	151Z3032	151Z3038	151Z3082
TMT 470	151Z3013	-	151Z3063	151Z3023	-	151Z3073	151Z3033	-	151Z3083
TMT 500	151Z3014	-	151Z3064	151Z3024	-	151Z3074	151Z3034	-	151Z3084
TMT 630	151Z3015	-	151Z3065	151Z3025	-	151Z3075	151Z3035	-	151Z3085

*TMT U versions*

Mounting flange	4-Bolt	
Spigot diameter	-	-
Bolt circle diameter (BC)	-	-
Shaft	-	-
Port size	G 3/4	1 1/16 - 12 UN
European version	●	
US version		●
Side port version	●	●
Standard shaft seal		
Drain connection	Yes	Yes
Check valve	No	No
<b>Code numbers</b>		
TMT U 250	151Z3000	151Z3100
TMT U 315	151Z3001	151Z3101
TMT U 400	151Z3002	151Z3102
TMT U 470	151Z3003	151Z3103
TMT U 500	151Z3004	151Z3104
TMT U 630	151Z3005	151Z3105

**Versions**
*TMT FL versions*

Mounting flange	4-Bolt					
	Spigot diameter	Ø 125 mm	Ø 125 mm	Ø 5 in	Ø 180 mm	Ø 180 mm
Bolt circle diameter (BC)	Ø 160 mm	Ø 160 mm	Ø 6.37 in	Ø 224 mm	Ø 224 mm	Ø 8.82 in
Shaft	Splined 1.5 in	Tap. 45 mm	Splined 1.5 in	Splined 1.5 in	Tap. 45 mm	Splined 1.5 in
Port size	G 3/4	G 3/4	1 1/16 - 12 UN	G 3/4	G 3/4	1 1/16 - 12 UN
European version	●	●		●	●	
US version			●			●
Side port version	●	●	●	●	●	●
Standard shaft seal	●	●	●	●	●	●
Drain connection	Yes	Yes	Yes	Yes	Yes	Yes
Check valve	No	No	No	No	No	No
<b>Code numbers</b>						
TMT FL 250	151Z3040	151Z3050	151Z3090	151Z3110	151Z3120	151Z3130
TMT FL 315	151Z3041	151Z3051	151Z3091	151Z3111	151Z3121	151Z3131
TMT FL 400	151Z3042	151Z3052	151Z3092	151Z3112	151Z3122	151Z3132
TMT FL 470	151Z3043	151Z3053	151Z3093	151Z3113	151Z3123	151Z3133
TMT FL 500	151Z3044	151Z3054	151Z3094	151Z3114	151Z3124	151Z3134
TMT FL 630	151Z3045	151Z3055	151Z3095	151Z3115	151Z3125	151Z3135

*TMTW / TMTW FL versions*

Mounting flange	Wheel		
	TMTW		TMTW FL
Spigot diameter	Ø 180 mm	Ø 180 mm	Ø 160 mm
Bolt circle diameter (BC)	Ø 210 mm	Ø 210 mm	Ø 194 mm
Shaft	Thread hole fl.	Thread hole fl.	Tap. 45 mm
Port size	G 3/4	1 1/16 - 12 UN	1 1/16 - 12 UN
European version	●		
US version		●	●
Side port version	●	●	●
Standard shaft seal	●	●	●
Drain connection	Yes	Yes	Yes
Check valve	No	No	No
<b>Code numbers</b>			
250	151Z3229	151Z3273	-
315	151Z3230	151Z3274	-
400	151Z3231	151Z3275	-
470	151Z3232	151Z3276	-
500	151Z3233	151Z3277	11033926
630	151Z3234	151Z3278	11033927

**Features available (options)**

- Flushing valve with different flushing flow
- Brake with higher holding torque capacity



## Versions

- Painted

## Code numbers

Displacement [cm <sup>3</sup> ]					
250	315	400	470	500	630
151Z3010	151Z3011	151Z3012	151Z3013	151Z3014	151Z3015
151Z3016	151Z3017	151Z3018	-	-	-
151Z3060	151Z3061	151Z3062	151Z3063	151Z3064	151Z3065
151Z3020	151Z3021	151Z3022	151Z3023	151Z3024	151Z3025
151Z3026	151Z3027	151Z3028	-	-	-
151Z3070	151Z3071	151Z3072	151Z3073	151Z3074	151Z3075
151Z3030	151Z3031	151Z3032	151Z3033	151Z3034	151Z3035
151Z3036	151Z3037	151Z3038	-	-	-
151Z3080	151Z3081	151Z3082	151Z3083	151Z3084	151Z3085
151Z3000	151Z3001	151Z3002	151Z3003	151Z3004	151Z3005
151Z3100	151Z3101	151Z3102	151Z3103	151Z3104	151Z3105
151Z3040	151Z3041	151Z3042	151Z3043	151Z3044	151Z3045
151Z3050	151Z3051	151Z3052	151Z3053	151Z3054	151Z3055
151Z3090	151Z3091	151Z3092	151Z3093	151Z3094	151Z3095
151Z3110	151Z3111	151Z3112	151Z3113	151Z3114	151Z3115
151Z3120	151Z3121	151Z3122	151Z3123	151Z3124	151Z3125
151Z3130	151Z3131	151Z3132	151Z3133	151Z3134	151Z3135
151Z3229	151Z3230	151Z3231	151Z3232	151Z3233	151Z3234
151Z3273	151Z3274	151Z3275	151Z3276	151Z3277	151Z3278
11033922	11033923	11033924		11033926	11033927
15	15	16	16	17	17

**Technical data**
**Technical data for TMT, TMTU, TMTW and TMT FL**
*Technical data for TMT, TMTU, TMTW and TMT FL*

Type Motor size			TMT 250	TMT 315	TMT 400	TMT 470	TMT 500	TMT 630
Geometric displacement	cm <sup>3</sup>		251.8	326.3	410.9	477.3	494.8	629.1
	[in <sup>3</sup> ]		[15.37]	[19.91]	[25.07]	[29.13]	[30.19]	[38.39]
Maximum speed	min <sup>-1</sup>	cont.	500	380	305	270	250	200
	[rpm]	int. <sup>(1)</sup>	600	460	360	320	300	240
Maximum torque	N·m [lbf·in]	cont.	940	1,230	1,520	1,760	1,770	1,830
		int. <sup>(1)</sup>	1,290	1,660	2,120	2,420	2,240	2,290
		peak <sup>(2)</sup>	1,440	1,865	2,355	2,735	2,390	2,740
Maximum output	kW [hp]	cont.	35	35	37	37	35	27
		int. <sup>(1)</sup>	47	47	51	49	42	33
Maximum pressure drop	bar [psi]	cont.	250	250	250	250	250	200
		int. <sup>(1)</sup>	350	350	350	350	325	250
		peak <sup>(2)</sup>	400	400	400	400	375	300
Maximum oil flow	l/min [US gal/min]	cont.	125	125	125	125	125	125
		int. <sup>(1)</sup>	150	150	150	150	150	150
Maximum starting pressure with unloaded shaft	bar [psi]		6	6	6	6	6	6
Minimum starting torque	at maximum pressure drop cont.		780	1,060	1,360	1,500	1,530	1,600
	at maximum pressure drop int. <sup>(1)</sup>		1,080	1,520	1,930	2,050	1,820	1,980
	N·m [lbf·in]		[6,690]	[9,380]	[12,040]	[13,280]	[13,540]	[14,160]
	N·m [lbf·in]		[9,560]	[13,450]	[17,080]	[18,140]	[16,100]	[17,500]

<sup>(1)</sup> Intermittent operation: the permissible values may occur for maximum 10% of every minute

<sup>(2)</sup> Peak load: the permissible value may occur for maximum 1% of every minute

Type		Max. inlet pressure		Max. return pressure with drain line	
		bar	[psi]	bar	[psi]
TMT 250 - 630	cont.	270	[3915]	140	[2030]
	int. <sup>(1)</sup>	370	[5365]	175	[2540]
	peak <sup>(2)</sup>	420	[6090]	210	[3045]

For max. permissible combination of flow and pressure, see function diagram for actual motor

**Technical data**

**Technical data for brake motor TMT FL and TMTW FL**

Technical data for brake motor TMT FL and TMTW FL				
Holding torque <sup>1)</sup>	N·m	2,000	[lbf·in]	[17,700]
Min. release pressure <sup>2)</sup>	bar	13	[psi]	[190]
Max. release pressure cont.	bar	20	[psi]	[365]
Max. release pressure peak	bar	40	[psi]	[580]

<sup>1)</sup> Brakes with higher holding torque available, please contact Danfoss.

<sup>2)</sup> The release pressure is the difference between the pressure in the brake line and the pressure in the drain line.

Bleed off from brake release chamber to drain line is 0.65 l/min [0.172 US gal/min] at 13 bar [188 psi] release pressure.

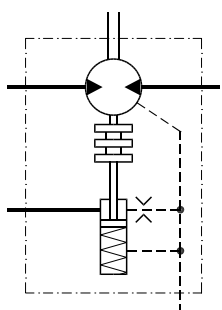

151-1931.10

**Maximal permissible shaft seal pressure**

TMT with standard shaft seal and drain connection.

The pressure on shaft seal equals the pressure in the drain line.

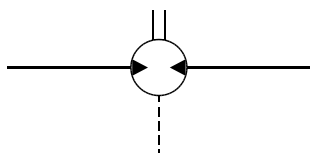

151-1983.10

TMT FL and TMTW FL with standard shaft seal.

The pressure on shaft seal equals the pressure in release port.

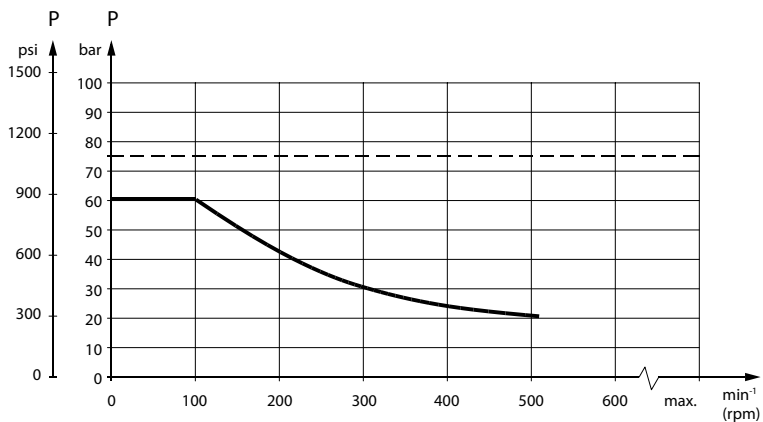

151-1673.10

**Technical data**

---- Intermittent operation: The permissible values may occur for max. 10% of every minute.

\_\_\_\_\_ Continuous operation

**Warning**

**Drain line should always be used.**

**Pressure drop in motor**

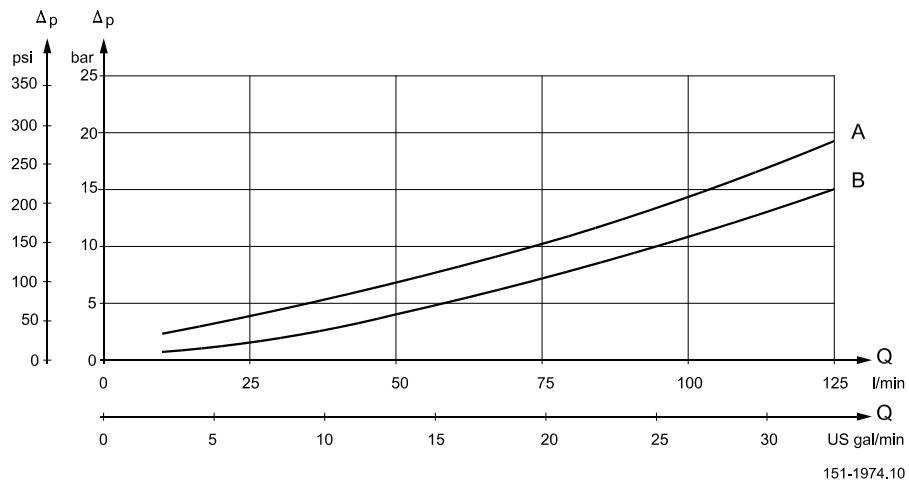

The curve applies to an unloaded motor shaft and an oil viscosity of 35 mm<sup>2</sup>/s [165 SUS].

**A:** TMT 250, 315

**B:** TMT 400, 470, 500 and 630

**Oil flow in drain line**

The table below shows the max. oil flow in the drain line at a return pressure less than 5-10 bar [75-150 psi].

Pressure drop		Viscosity		Oil flow in drain line	
bar	[psi]	mm <sup>2</sup> /s	[SUS]	l/min	[US gal/min]
200	[2900]	20	[100]	2.5	[0.66]
		35	[165]	1.5	[0.40]
275	[3990]	20	[100]	4.0	[1.10]
		35	[165]	2.5	[0.66]

**Technical data**

**Direction of shaft rotation**

*TMTW*

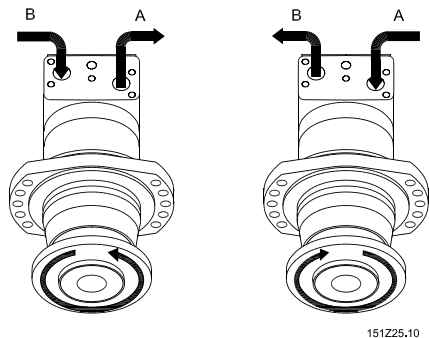

*TMT*

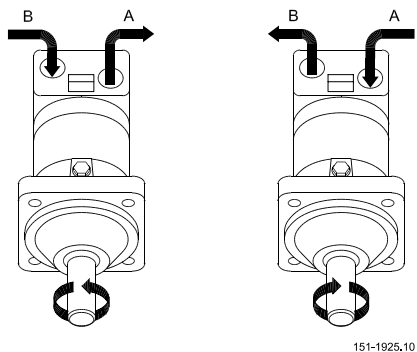

*TMT FL*

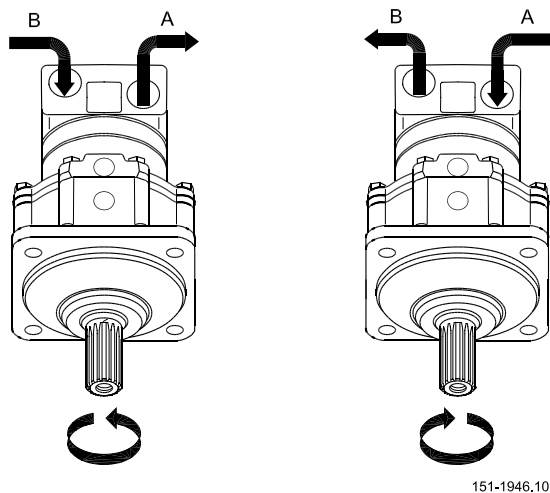

**Permissible radial shaft load**

The output shaft runs in tapered roller bearings that permit high axial and radial forces.

The permissible radial load on the shaft is shown for an axial load of 0 N as a function of the distance from the mounting flange to the point of load application.

**Technical data**

The curve is based on B10 Bearing life (2,000 hours or 12,000,000 shaft revolutions at 100 min<sup>-1</sup>) at rated output torque, when mineral-based hydraulic oil with a sufficient content of anti-wear additives, is used.

The dash curve **A** shows max. radial shaft load. Any shaft load exceeding the values shown in the curve will involve a risk of breakage.

**Permissible shaft load for TMT and TMT FL**

Spigot diameter Ø160 mm [6.3 in] TMT and Ø180 mm [7.1 in] TMT FL

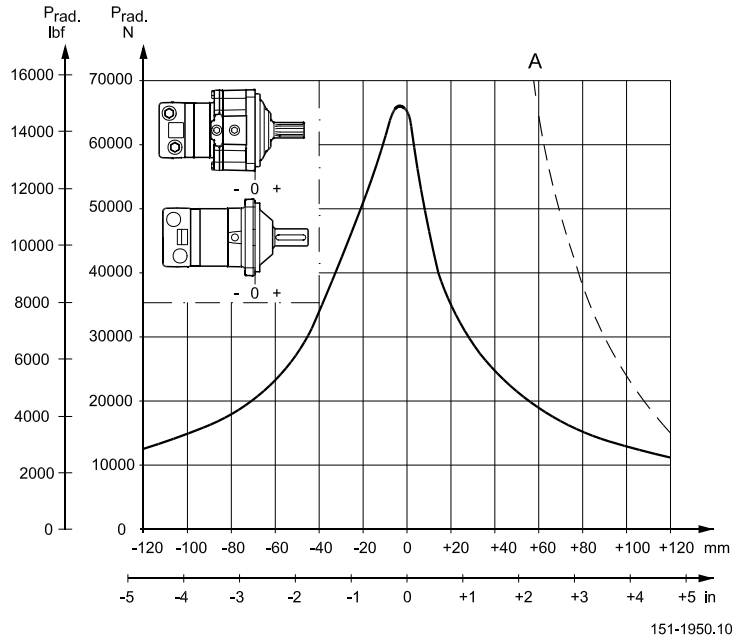

Spigot diameter Ø125 mm [4.92 in] TMT and TMT FL

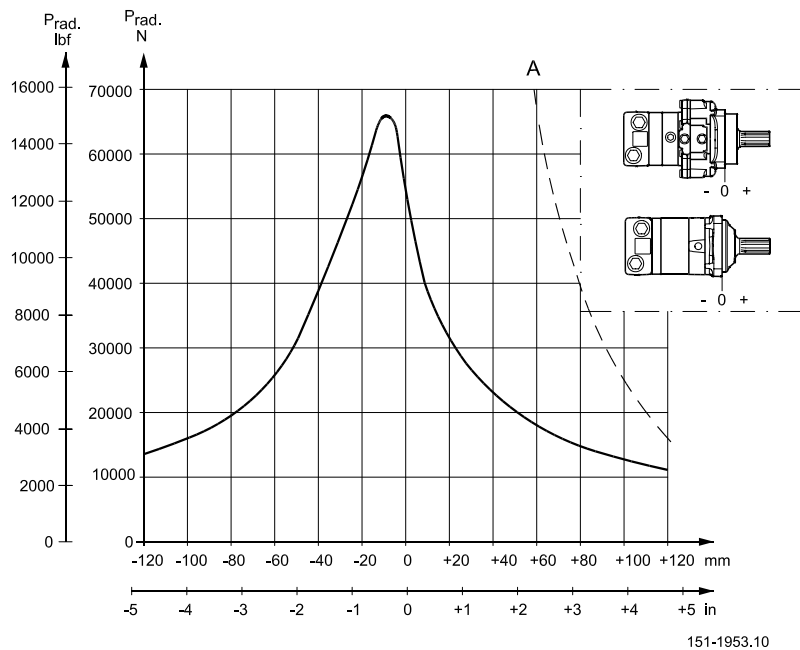

**Technical data**

*Spigot diameter Ø 127 mm [5.0 in] TMT and TMT FL*

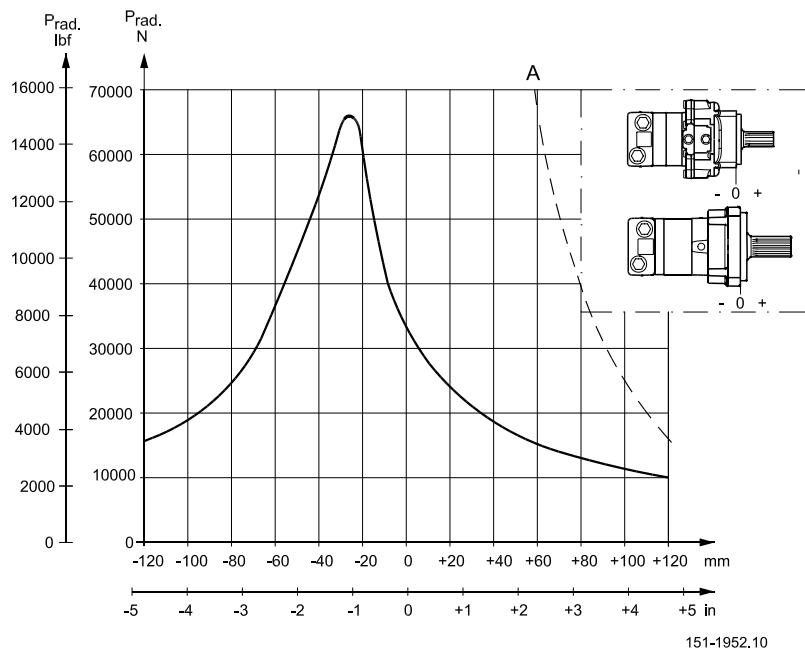

**Permissible radial shaft load for TMTW**

*Permissible Shaft Load for TMTW*

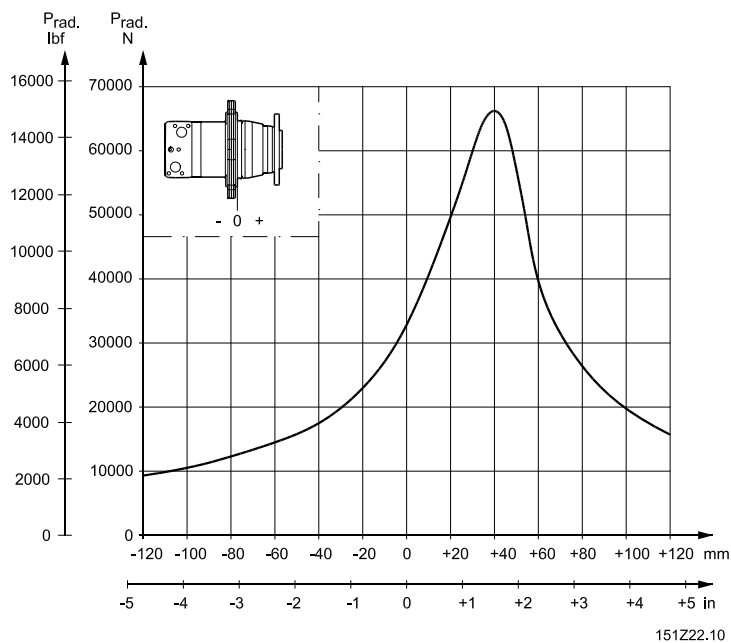

**Technical data**

**Permissible radial shaft load for TMTW FL**

*Permissible Shaft Load for TMTW FL*

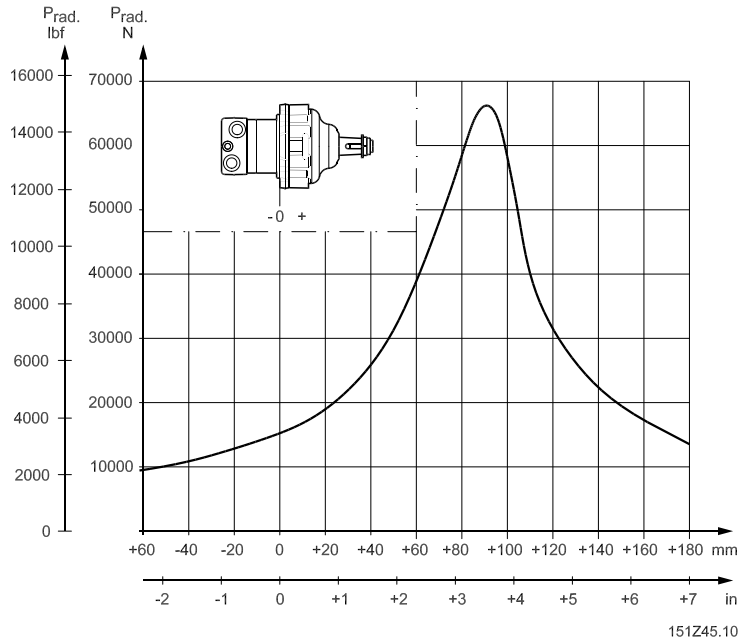



**Function diagrams**

**Function diagrams**

Explanation of function diagram use, basis and conditions can be found in [Speed and torque](#) on page 6.

**Blue:** Continuous range

**Red:** Intermittent range (max. 10% operation every minute)

Intermittent pressure drop and oil flow must not occur simultaneously.

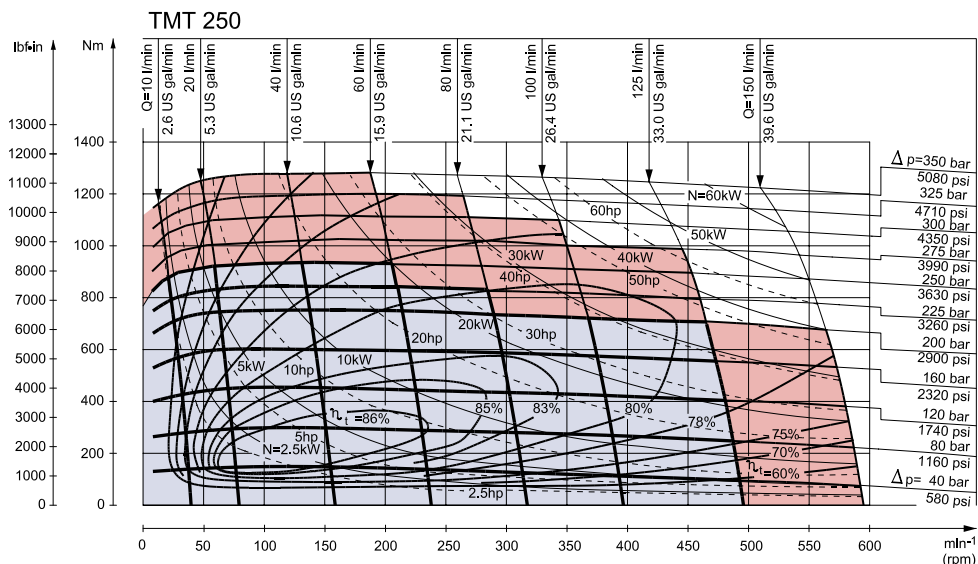

151-1988.11

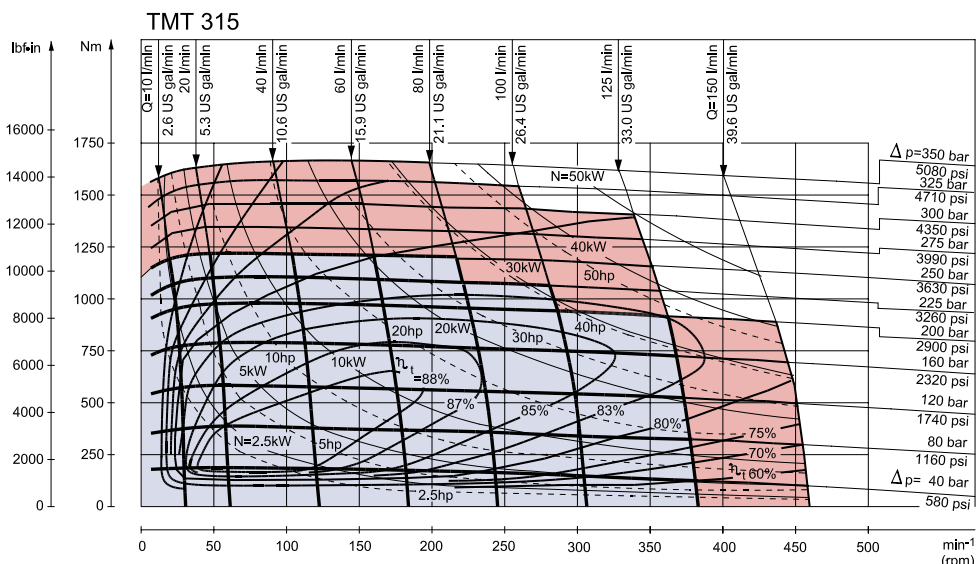

151-1989.11

**Function diagrams**

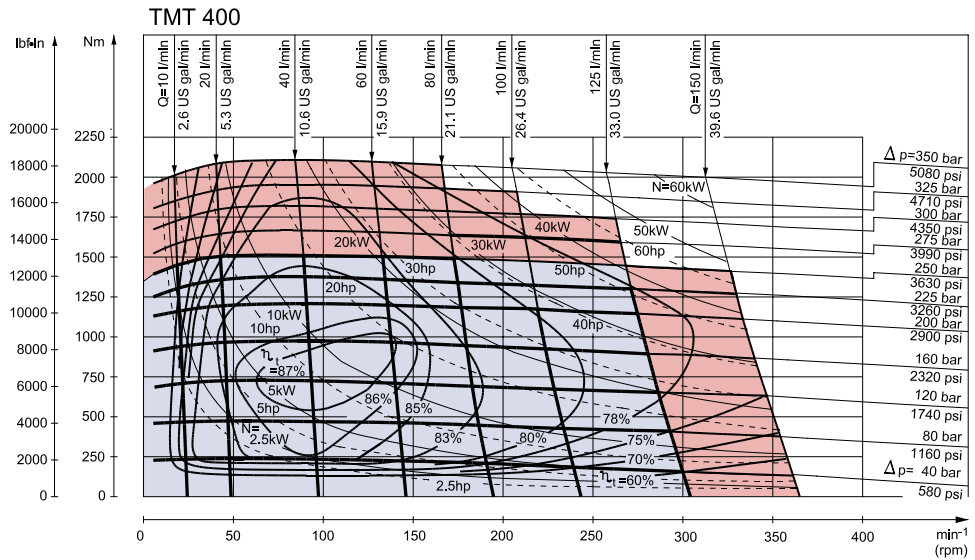

151-1987.11

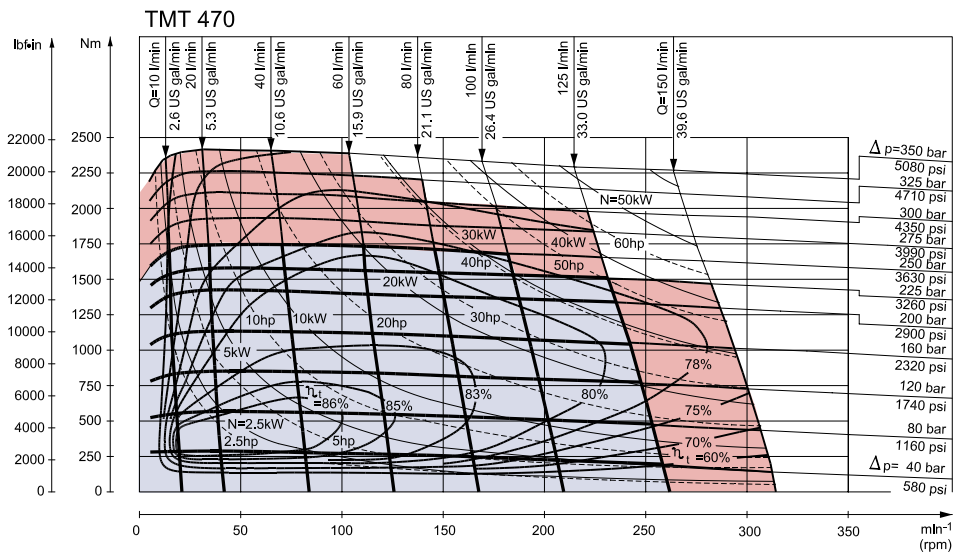

151-1986.12

**Function diagrams**

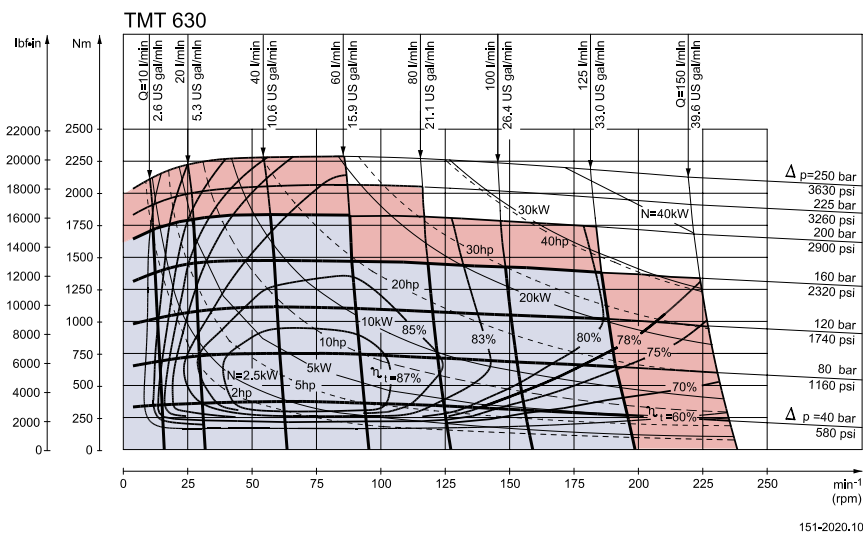
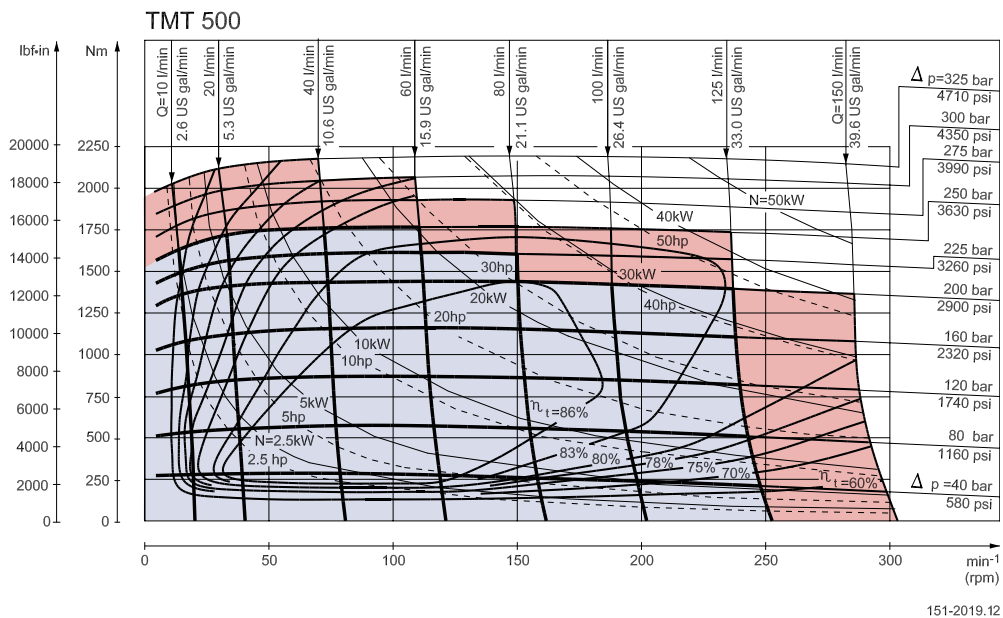

**Shaft version**

**TMT shaft, European versions**

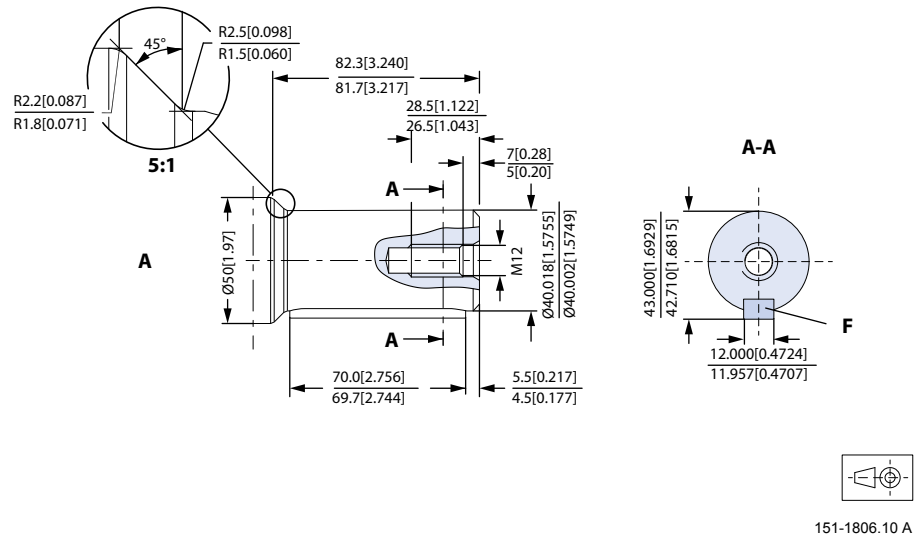

- A:** Cylindrical shaft  $\varnothing$  40 mm
- F:** Parallel key, A12 x 8 x 70, DIN 6885

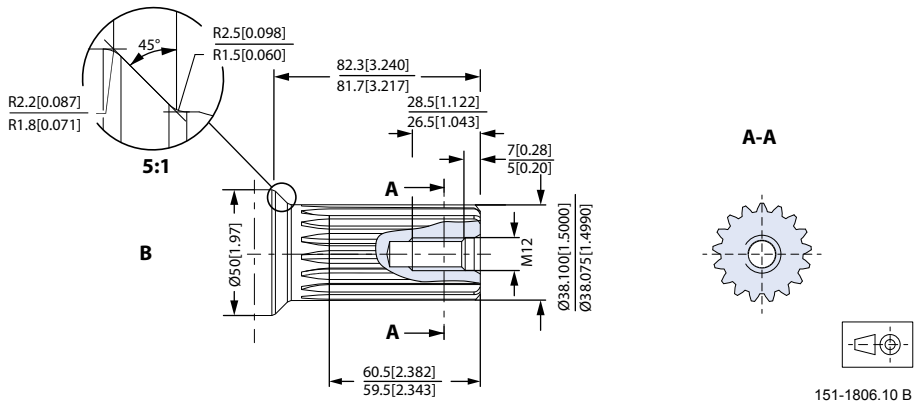

- B:** Involute splined shaft ANS B92.1 - 1970 standard, Flat root side fit, Pitch 12/24, Teeth 17, Major diameter 1.50 inch, Pressure angle 30°

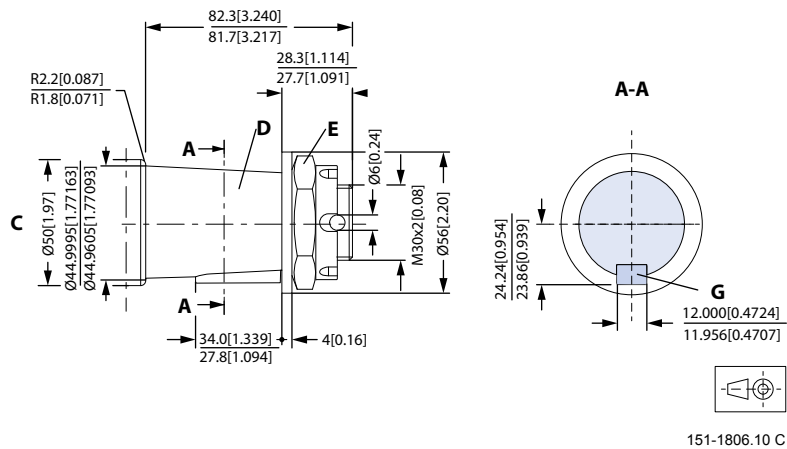

**Shaft version**

- C:** Tapered shaft  $\varnothing$  45 mm, (ISO/R775)
- E:** DIN 937, Across flats: 46 mm, Tightening torque:  $500 \pm 30$  N•m [ $4425 \pm 265$  lbf•in]
- D:** Taper 1 : 10
- G:** Parallel key, B12 x 8 x 28

**TMT shaft, US versions**

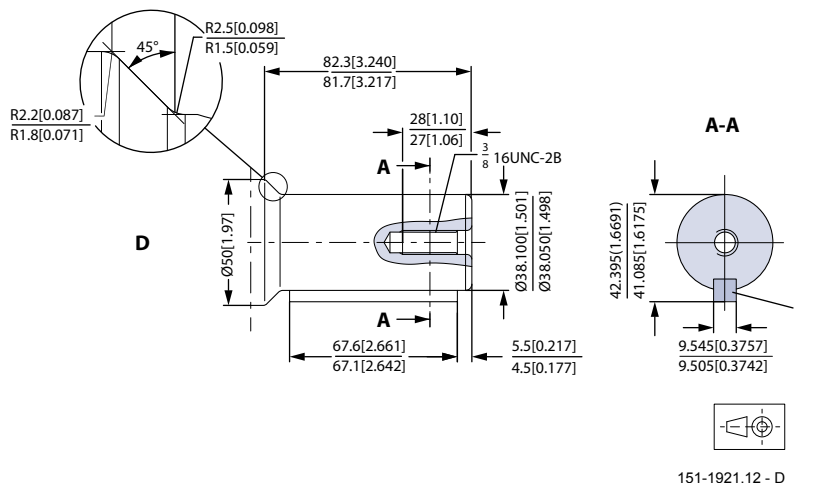

151-1921.12 - D

- D:** Cylindrical shaft,  $\varnothing$  1 1/2 inch
- I:** Parallel key, 3/8 x 3/8 x 2 1/4 inch, B.S. 46

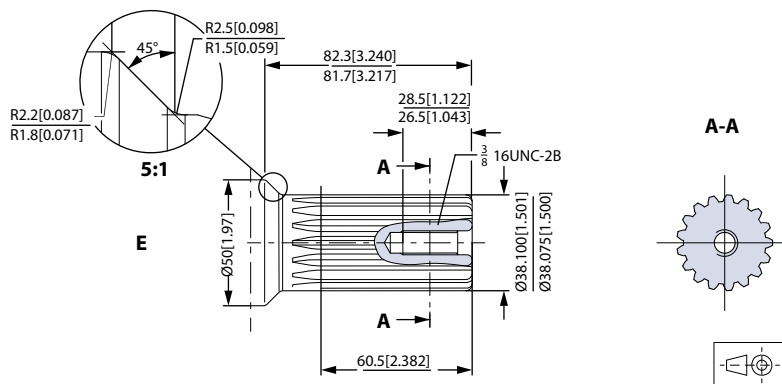

151-1921.12 - E

- E:** Involute splined shaft ANS B92.1 - 1970 standard, Flat root side fit, Pitch 12/24, Teeth 17, Major diameter 1.50 inch, Pressure angle 30°

Shaft version

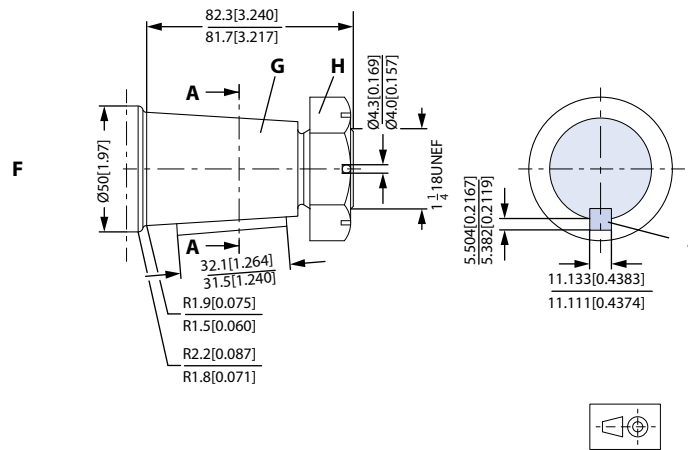

151-1921.12 - F

**F:** Tapered shaft 1 3/4 in

**G:** Cone 1 : 8, SAE J501

**H:** 1 1/4 - 18 UNEF across flats: 2 3/16 inch, Tightening torque: 4425 ± 265 lbf.in [500 ± 30 N•m]

**J:** Parallel key, 7/16 x 7/16 x 1 1/4 inch, B.S. 46

## Technical data

### Port thread versions

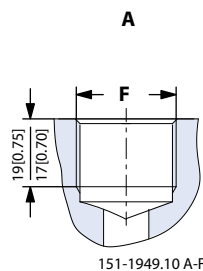

**A:** G Main port  
**F:** ISO 228/1 – G 3/4

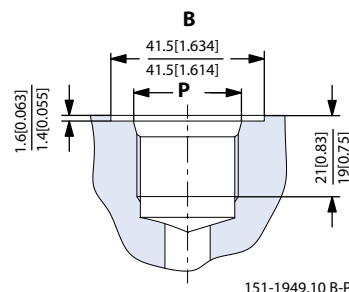

**B:** UNF Main port  
**P:** 1 1/16 – 12 UN

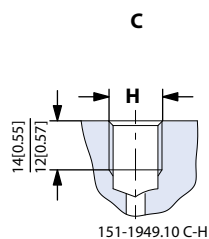

**C:** G Drain/release port  
**H:** ISO 228/1 – G 1/4

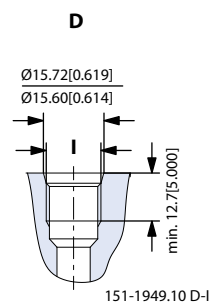

**D:** UNF Drain port  
**I:** 9/16 – 18 UNF O-ring boss port

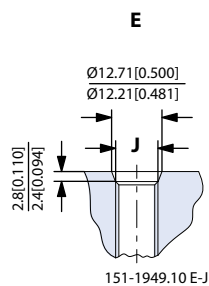

**E:** UNF Release port  
**J:** 7/16 – 20 UNF O-ring boss port

**Dimensions – attached component**

**Dimensions of the attached component for TMTU (bearing less)**

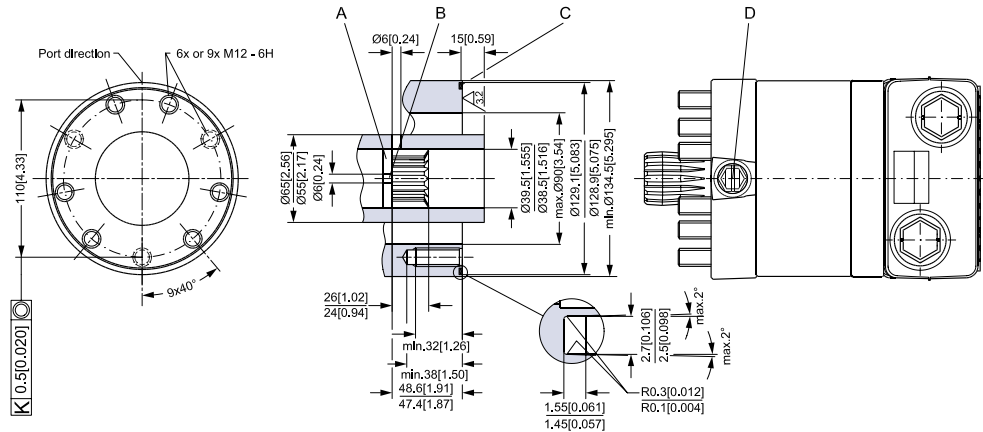

151-1920,10

- A:** Hardened stop plate
- B:** Oil circulation hole
- C:** O-ring 125 x 2 mm [0.08 in]
- D:** Drain connection

**Internal spline data for the component to be attached**

The attached component must have internal splines corresponding to the external splines on the motor cardan shaft, please see drawings.

Material:

Case hardening steel with a tensile strength corresponding at least to 20 MoCr4 (90 daN/mm<sup>2</sup>). See also SAE 8620 for further information on steel material.

Hardening specification:

- on the surface: HV = 750 ±50
- 0.7 ±0.2 mm under the surface: HV = 560

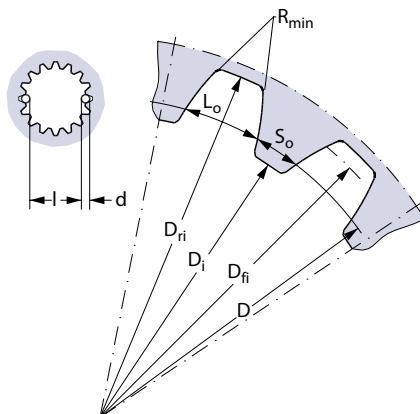

151-455.10



**Dimensions – attached component**

<b>Standard ANS B92.1 - 1970, class 5 (corrected m . x = 1; m = 2.1166)</b>			
<b>Flat root side fit</b>		<b>mm</b>	<b>[inch]</b>
Number of teeth	z	16	
Pitch DP		12/24	
Pressure angle		30°	
Pitch diameter	D	33.8656	[1.3333]
Major diameter	D <sub>n</sub>	38.4 +0.4/0	[1.5118 +0.0157/0]
Form diameter (minimum)	D <sub>fi</sub>	37.6	[1.4803]
Minor diameter	D <sub>i</sub>	32.15 +0.04/0	[1.2657 +0.00157/0]
Space width (circular)	Lo	4.516 ±0.037	[0.1777 ±0.0014]
Tooth thickness (circulator)	S <sub>o</sub>	2.170	[0.0854]
Fillet radius	R <sub>min.</sub>	0.5	[0.02]
Maximum measurement between pins*	l	26.9 +0.1/0	[1.059 +0.004/0]
Pin diameter	d	4.843 ±0.001	[0.1903 ±0.00004]

\* Finished dimensions (when hardened)

## Dimensions

### Drain connection on TMTU or attached component

A drain line should always be used.

The drain line can be connected at two different points:

- at the motor drain connection
- at the drain connection of the attached component

If a drain is fitted to the attached component, it must be possible for oil to flow freely between motor and the attached component.

The drain line must be led to the tank in such a way that there is no risk of the motor and the attached component being drained of oil when at rest.

The maximum pressure in the drain line is limited by the attached component and its shaft seal.

### Blank shaft

A blank shaft is available for TMTU motor, please contact Danfoss Sales Organisation.

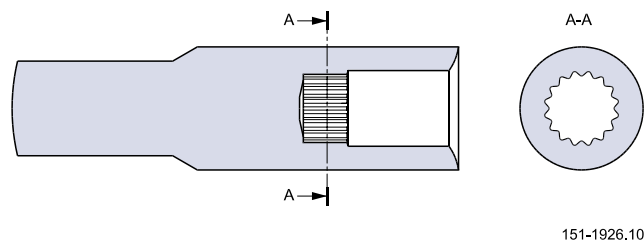

After machining the blank shaft must be hardened according to Danfoss specification in [Internal spline data for the component to be attached](#) on page 24.

## Dimensions

### TMT dimensions

#### European version

4-Bolt flange-spigot diameter  $\varnothing 160$  mm - BC  $\varnothing 200$  mm

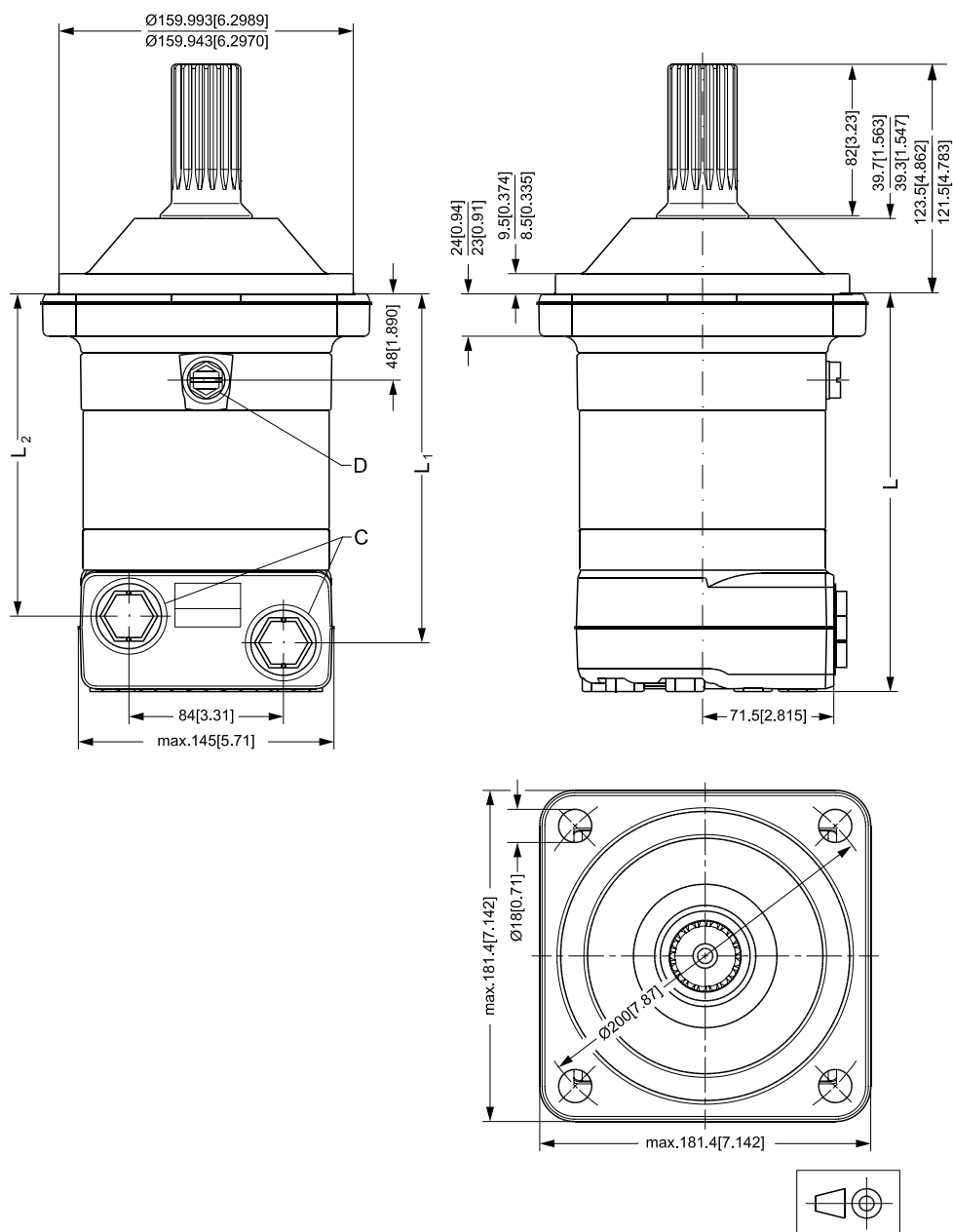

- C:** G 3/4 ; 17 mm [0.67 in] deep
- D:** Drain connection G 1/4 ; 12 mm [0.47 in] deep

**Dimensions**

*4-Bolt flange-spigot diameter Ø160 mm - BC Ø200 mm*

Type	L		L <sub>1</sub>		L <sub>2</sub>	
	mm	[in]	mm	[in]	mm	[in]
TMT 250	191.5	[7.54]	165.0	[6.50]	150.5	[5.93]
TMT 315	200.8	[7.91]	174.3	[6.86]	158.9	[6.26]
TMT400	211.3	[8.32]	184.8	[7.28]	170.3	[6.70]
TMT 470	219.5	[8.64]	193.0	[7.60]	178.5	[7.03]
TMT 500	211.3	[8.32]	184.8	[7.28]	170.3	[6.70]
TMT 630	225.3	[8.87]	198.8	[7.83]	184.3	[7.26]

**Dimensions**

4-bolt flange-spigot diameter  $\varnothing 125$  mm - BC  $\varnothing 160$  mm

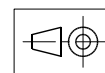
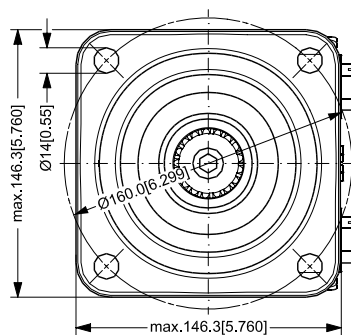
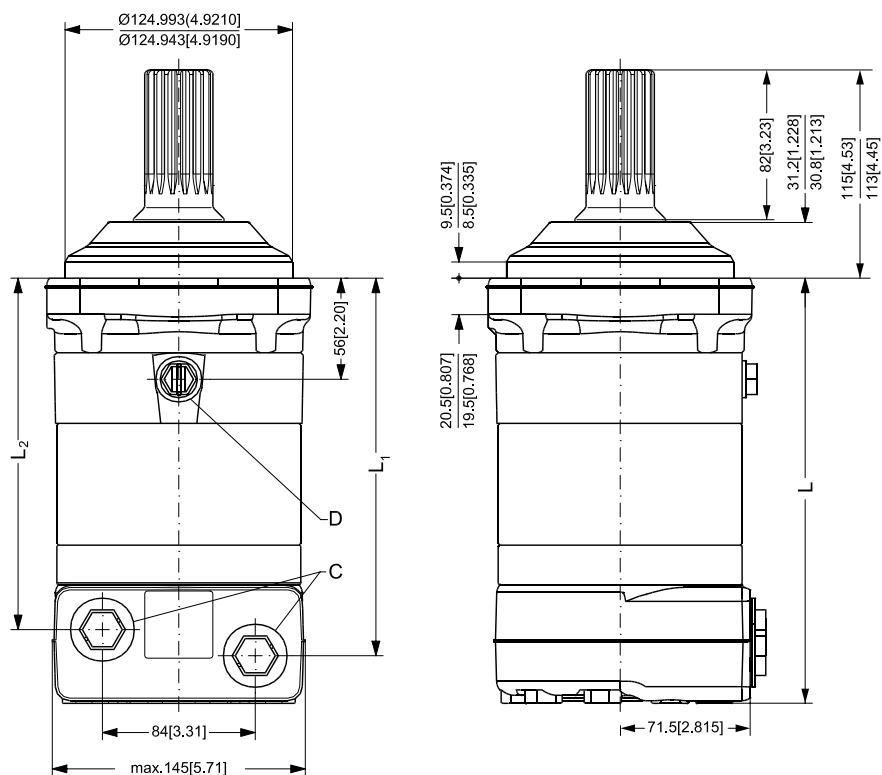

151-1929.12

- C:** G 3/4 ; 17 mm [0.67] deep
- D:** Drain connection G 1/4 ; 12 mm [0.47 in] deep

**Dimensions**

*4-bolt flange-spigot diameter Ø125 mm - BC Ø160 mm*

Type	L		L <sub>1</sub>		L <sub>2</sub>	
	mm	[in]	mm	[in]	mm	[in]
TMT 250	200.0	[7.87]	173.5	[6.83]	159.0	[6.26]
TMT 315	209.3	[8.24]	182.8	[7.20]	168.3	[6.63]
TMT400	219.8	[8.65]	193.3	[7.61]	178.8	[7.04]
TMT 470	228.0	[8.98]	201.5	[7.93]	187.0	[7.36]
TMT 500	219.8	[8.65]	193.3	[7.61]	178.8	[7.04]
TMT 630	233.8	[9.20]	207.3	[8.16]	192.8	[7.59]

## Dimensions

### US version

4-bolt flange-spigot diameter Ø5 in, SAE C mounting flange - BC Ø6.37 in

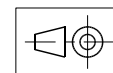
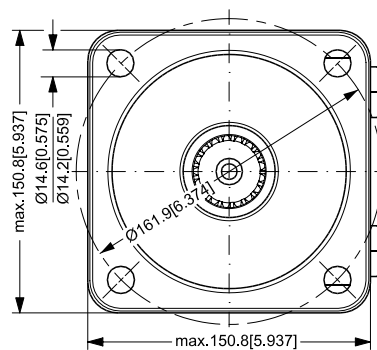
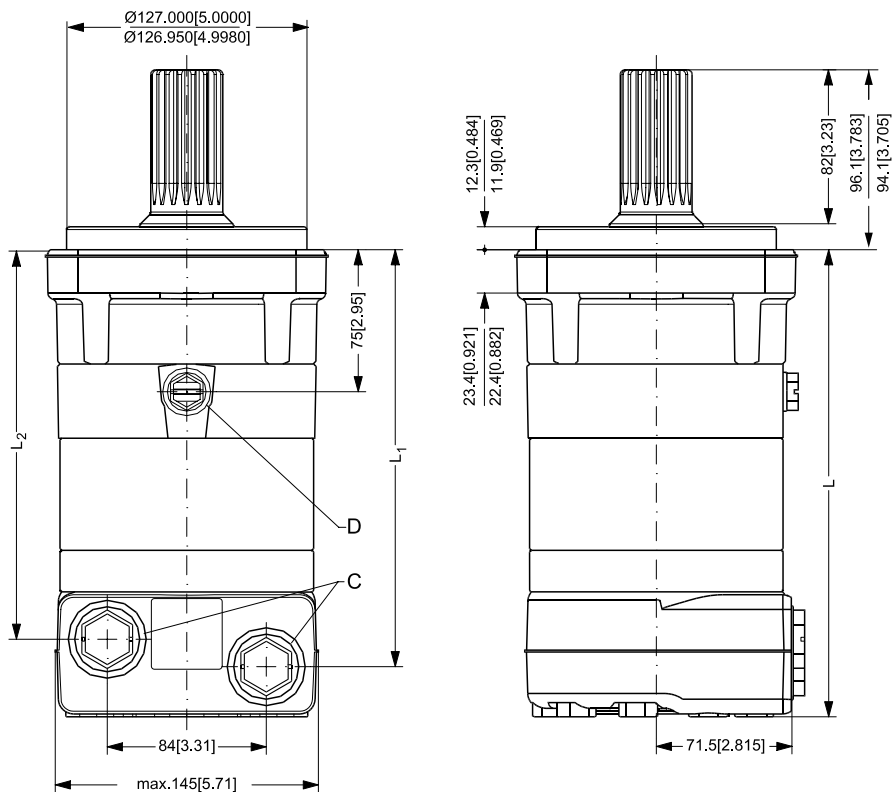

151-1932.12

**C:** 1 1/16 - 12 UN O-ring boss port; 19 mm [0.75 in] deep

**D:** Drain connection 9/16 - 18 UNF O-ring boss port; 12.7 mm [0.5 in] deep

Dimensions

4-bolt flange-spigot diameter Ø5 in, SAE C mounting flange - BC Ø6.37 in

Type	L		L <sub>1</sub>		L <sub>2</sub>	
	mm	[in]	mm	[in]	mm	[in]
TMT 250	218.7	[8.61]	192.4	[7.57]	177.9	[7.00]
TMT 315	227.9	[8.97]	201.7	[7.94]	187.2	[7.37]
TMT400	238.4	[9.39]	212.2	[8.35]	197.7	[7.78]
TMT 470	246.7	[9.71]	220.4	[8.68]	205.9	[8.11]
TMT 500	238.4	[9.39]	212.2	[8.35]	197.7	[7.78]
TMT 630	252.4	[9.94]	226.2	[8.91]	211.7	[8.33]

TMTU dimensions

European version

Bearing less

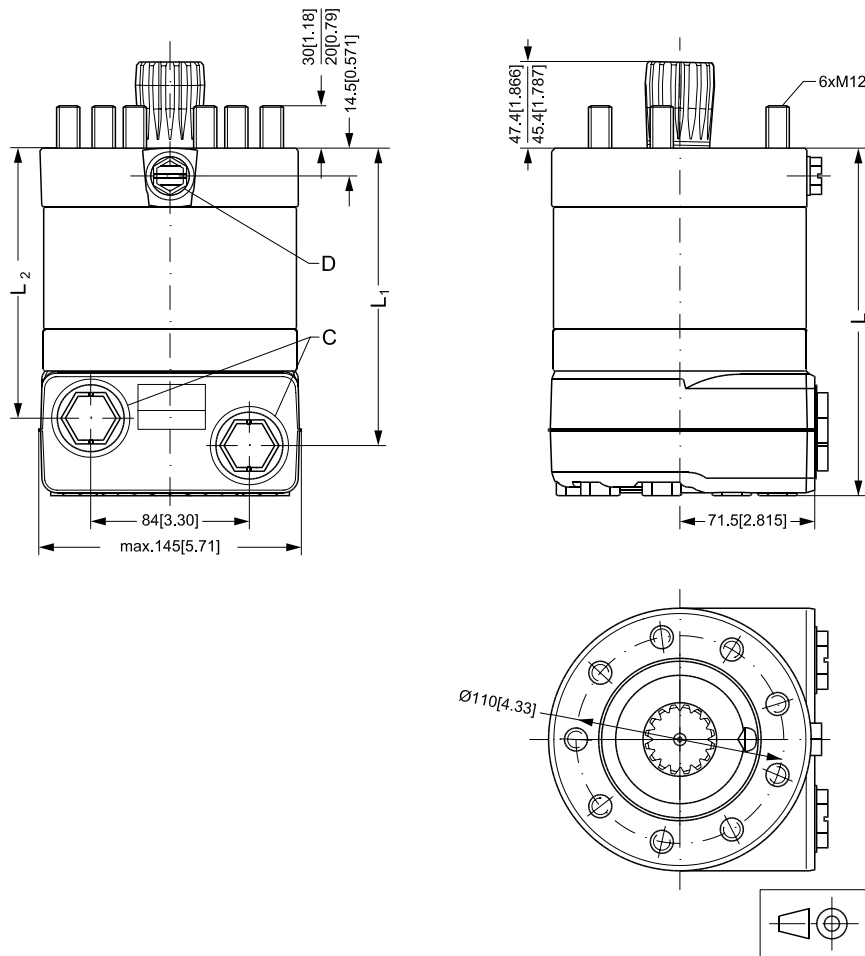

151-1800.11

**C:** G 3/4 ; 17 mm [0.67 in] deep



## Dimensions

### Bearing less

Type	L		L <sub>1</sub>		L <sub>2</sub>	
	mm	[in]	mm	[in]	mm	[in]
TMTU 250	158.5	[6.24]	131.0	[5.16]	117.5	[4.63]
TMTU 315	168.8	[6.65]	141.3	[5.56]	126.8	[4.99]
TMTU 400	178.3	[7.02]	151.8	[5.98]	137.3	[5.41]
TMTU 470	186.5	[7.32]	160.0	[6.26]	145.5	[5.73]
TMTU 500	178.3	[7.02]	151.8	[5.98]	137.3	[5.41]
TMTU 630	192.3	[7.57]	165.8	[6.53]	151.3	[5.96]

### US version

#### Bearing less

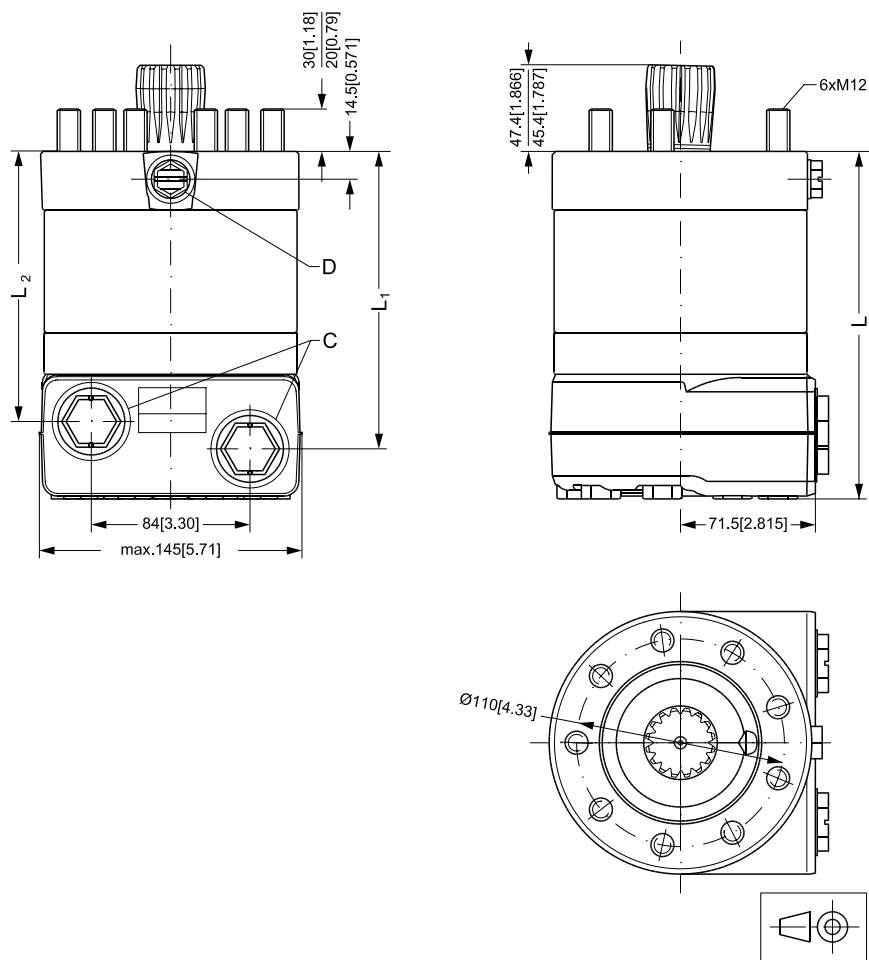

151-1800.11

**C:** 1 1/16 - 12 UN O-ring boss port; 19 mm [0.75 in] deep

**D:** Drain connection 9/16 - 18 UNF O-ring boss port; 12.7 mm [0.5 in] deep

**Dimensions**

*Bearing less*

Type	L		L <sub>1</sub>		L <sub>2</sub>	
	mm	[in]	mm	[in]	mm	[in]
TMTU 250	158.5	[6.24]	131.0	[5.16]	117.5	[4.63]
TMTU 315	168.8	[6.65]	141.3	[5.56]	126.8	[4.99]
TMTU 400	178.3	[7.02]	151.8	[5.98]	137.3	[5.41]
TMTU 470	186.5	[7.32]	160.0	[6.26]	145.5	[5.73]
TMTU 500	178.3	[7.02]	151.8	[5.98]	137.3	[5.41]
TMTU 630	192.3	[7.57]	165.8	[6.53]	151.3	[5.96]

**Dimensions**

**TMT FL dimensions**

**European version**

4-bolt flange-spigot diameter  $\varnothing 125$  mm - BC  $\varnothing 160$  mm

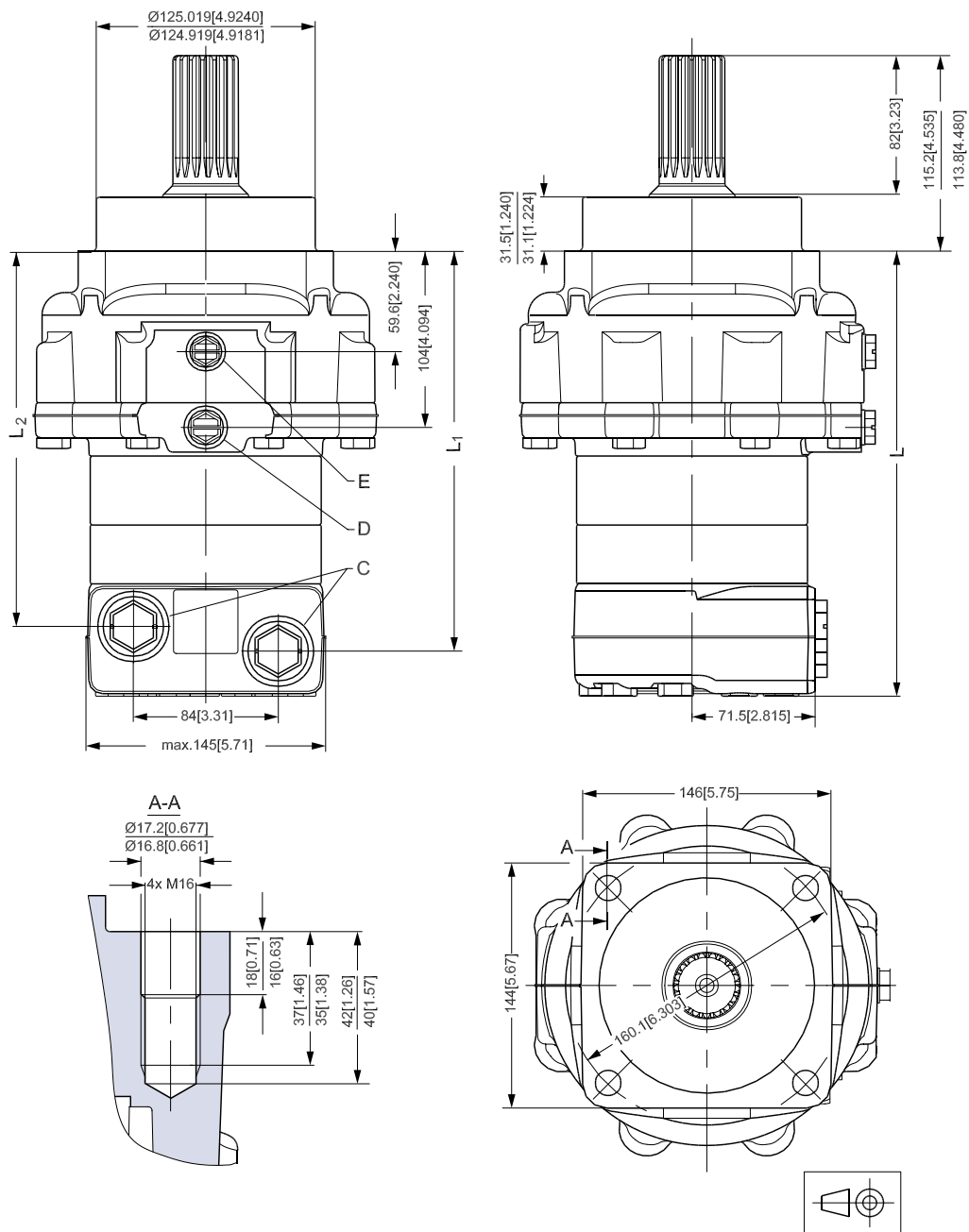

- C:** G 3/4; 17 mm [0.67 in] deep
- D:** Drain connection G 1/4; 12 mm [0.47 in] deep

**Dimensions**

*4-bolt flange-spigot diameter Ø125 mm - BC Ø160 mm*

Type	L		L <sub>1</sub>		L <sub>2</sub>	
	mm	[in]	mm	[in]	mm	[in]
TMT 250 FL	240.1	[9.45]	213.6	[8.41]	199.1	[7.84]
TMT 315 FL	249.4	[9.82]	222.9	[8.78]	208.4	[8.20]
TMT 400 FL	259.9	[10.23]	233.4	[9.19]	218.9	[8.62]
TMT 470 FL	268.2	[10.56]	241.7	[9.52]	227.2	[8.94]
TMT 500 FL	259.9	[10.23]	233.4	[9.19]	218.9	[8.62]
TMT 630 FL	273.9	[10.78]	247.4	[9.74]	232.9	[9.17]

**Dimensions**

4-Bolt flange-spigot diameter  $\varnothing 180$  mm - BC  $\varnothing 224$  mm

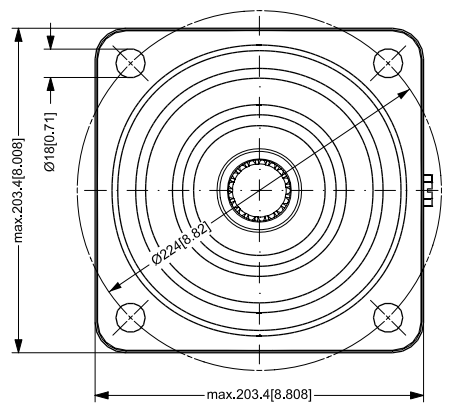
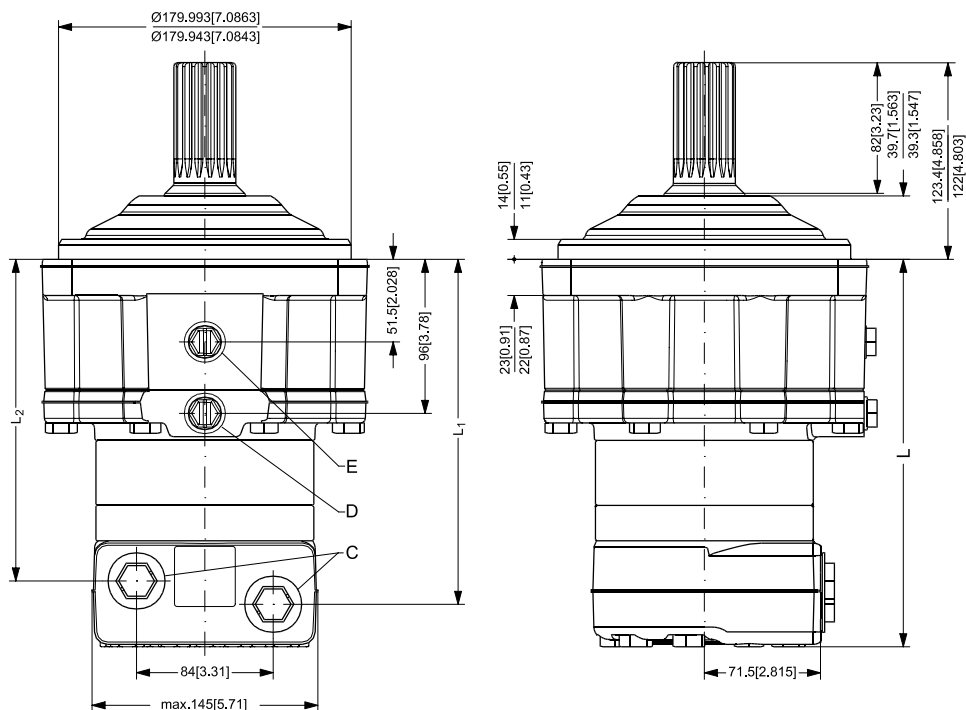

151-1928.12

- C:** G 3/4; 17 mm [0.67 in] deep
- D:** Drain connection G 1/4; 12 mm [0.47 in] deep
- E:** Release port G 1/4; 12 mm [0.47 in] deep

## Dimensions

4-Bolt flange-spigot diameter Ø180 mm - BC Ø224 mm

Type	L		L <sub>1</sub>		L <sub>2</sub>	
	mm	[in]	mm	[in]	mm	[in]
TMT 250 FL	232.0	[9.13]	205.5	[8.09]	191.0	[7.52]
TMT 315 FL	224.1.2	[9.50]	214.7	[8.45]	200.2	[7.88]
TMT 400 FL	251.7	[9.91]	225.2	[8.87]	210.7	[8.30]
TMT470 FL	260.0	[10.24]	233.5	[9.19]	219.0	[8.62]
TMT 500 FL	251.7	[9.91]	225.2	[8.87]	210.7	[8.30]
TMT 630 FL	265.7	[10.46]	239.2	[9.42]	224.7	[8.85]

## US version

4-bolt flange-spigot diameter Ø5 in, SAE C mounting flange - BC Ø6.37 in

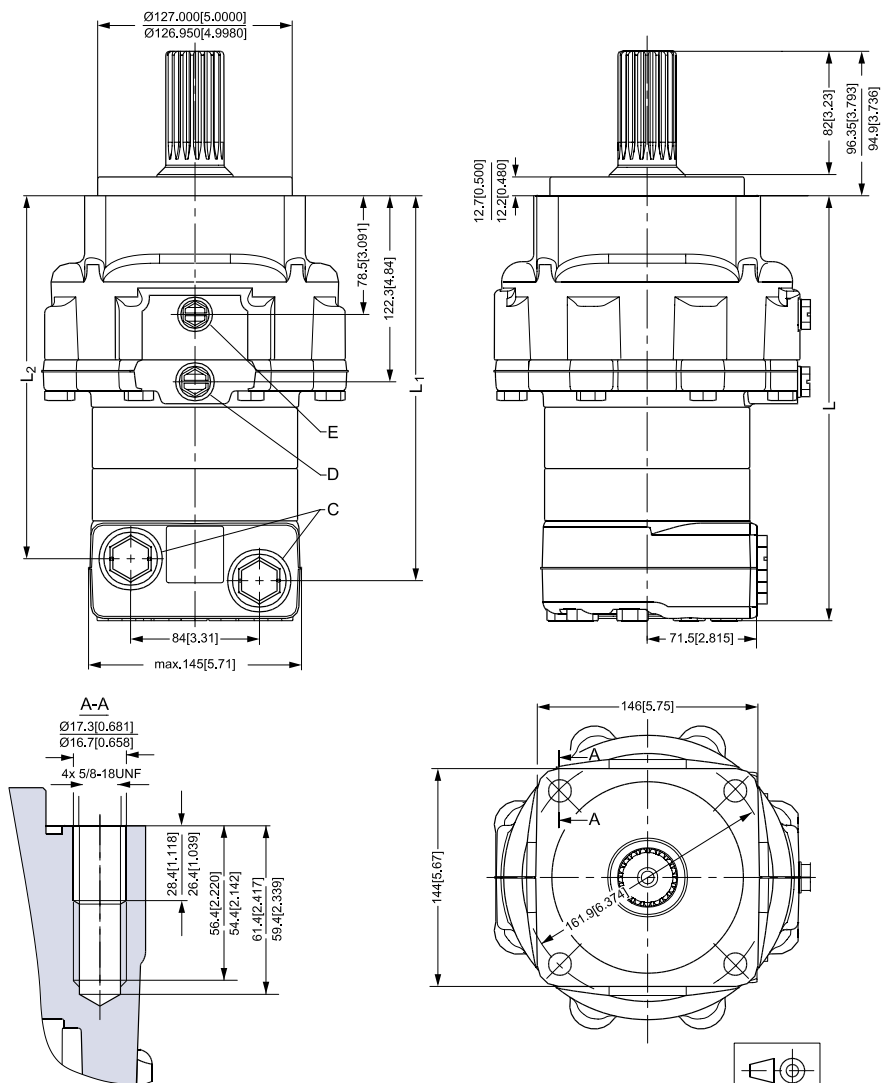

151-1941.13.22

**Dimensions**

**C:** 1 1/16 - 12 UN O-ring boss port; 19 mm [0.75 in] deep

**D:** Drain connection 9/16 - 18 UNF O-ring boss port; 12.7 mm [0.5 in] deep

**E:** Release port 7/16 - 20 UNF O-ring boss port; 12.7 mm [0.5 in] deep

*4-bolt flange-spigot diameter Ø5 in, SAE C mounting flange - BC Ø6.37 in*

Type	L		L <sub>1</sub>		L <sub>2</sub>	
	mm	[in]	mm	[in]	mm	[in]
TMT 250 FL	259.0	[10.20]	232.5	[9.15]	218.0	[8.58]
TMT 315 FL	268.3	[10.56]	241.8	[9.52]	227.3	[8.95]
TMT 400 FL	278.8	[10.98]	252.3	[9.93]	237.8	[9.36]
TMT 470 FL	287.0	[11.30]	260.5	[10.26]	246.0	[9.69]
TMT 500 FL	278.8	[10.98]	252.3	[9.93]	237.8	[9.36]
TMT 630 FL	292.8	[11.53]	266.3	[10.48]	251.8	[9.91]

**Dimensions**

4-bolt flange-spigot diameter  $\varnothing 7.08$  in - BC  $\varnothing 8.82$  in

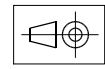
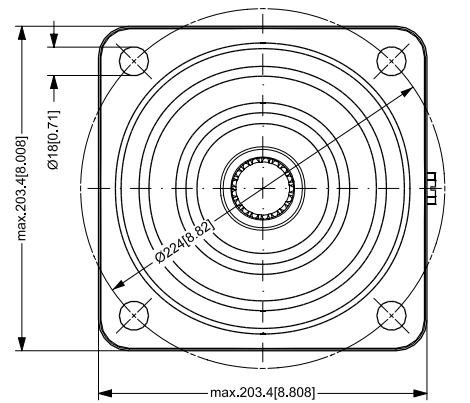
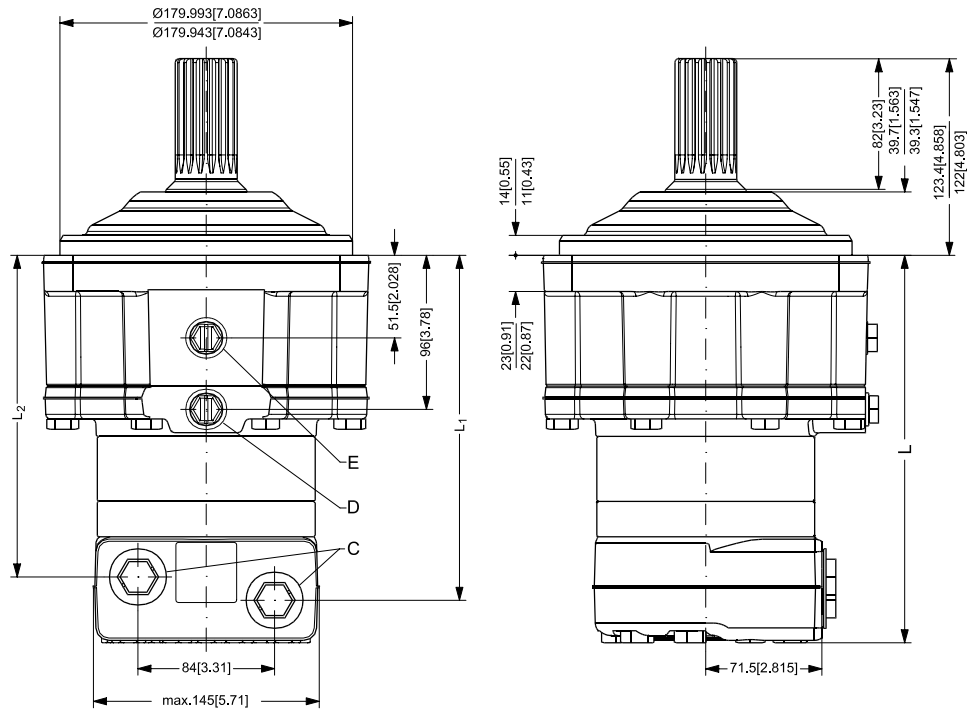

151-1928.12

- C:** 1 1/16 - 12 UN O-ring boss port; 19 mm [0.75 in] deep
- D:** Drain connection 9/16 - 18 UNF O-ring boss port; 12.7 mm [0.5 in] deep
- E:** Release port 7/16 - 20 UNF O-ring boss port; 12.7 mm [0.5 in] deep



**Dimensions**

*4-bolt flange-spigot diameter Ø7.08 in - BC Ø8.82 in*

Type	L		L <sub>1</sub>		L <sub>2</sub>	
	mm	[in]	mm	[in]	mm	[in]
TMT 250 FL	232.0	[9.13]	205.5	[8.09]	191.0	[7.52]
TMT 315 FL	241.2	[9.50]	214.7	[8.45]	200.2	[7.88]
TMT 400 FL	251.7	[9.91]	225.2	[8.87]	210.7	[8.30]
TMT470 FL	260.0	[10.24]	233.5	[9.19]	219.0	[8.62]
TMT 500 FL	251.7	[9.91]	225.2	[8.87]	210.7	[8.30]
TMT 630 FL	265.7	[10.46]	239.2	[9.42]	224.7	[8.85]

**Dimensions**

**TMTW dimensions**

**European version**

Wheel - Spigot diameter  $\varnothing 180$  mm - BC  $\varnothing 210$  mm

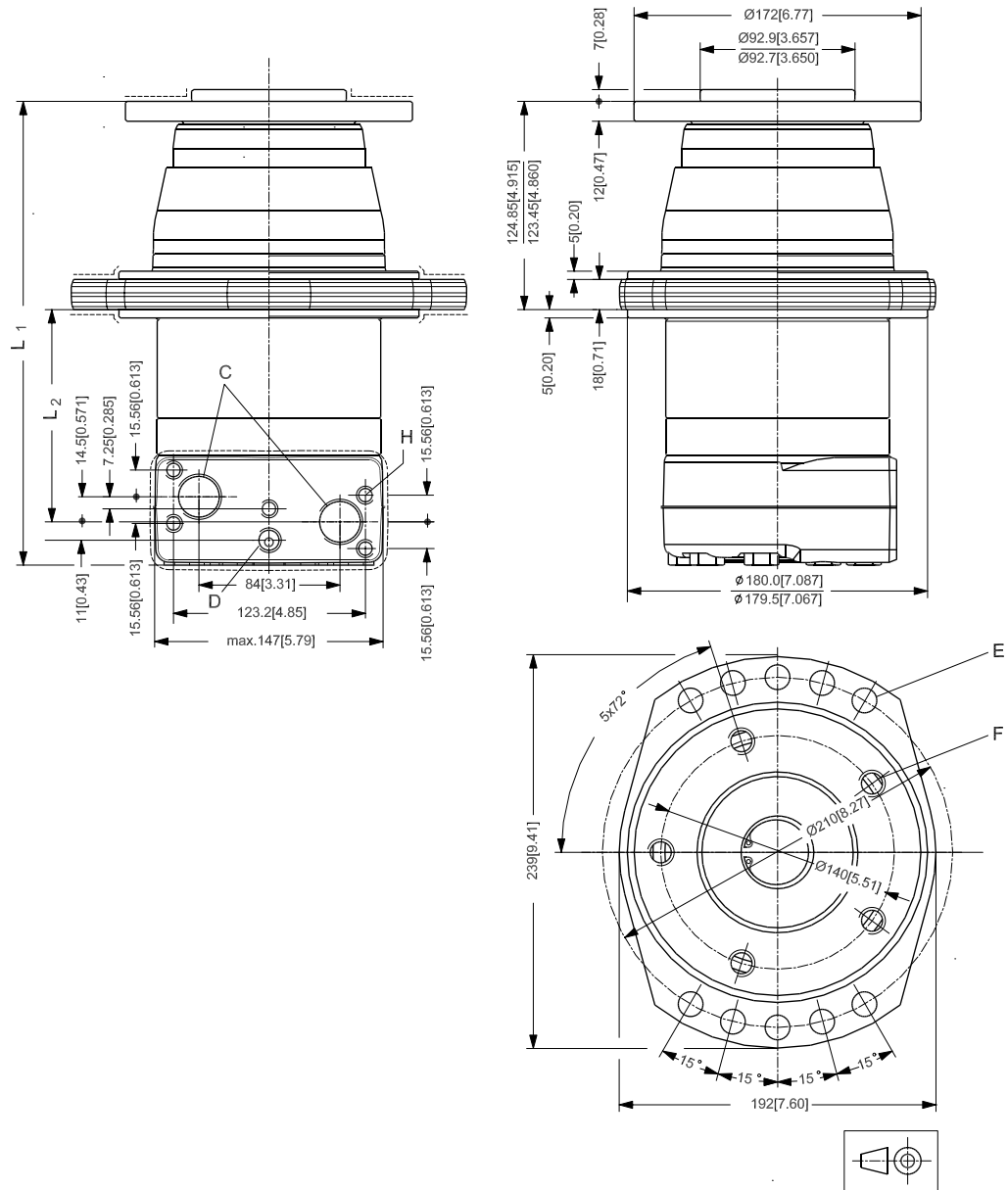

151Z08.16

- C:** G 3/4; 17 mm [0.67 in] deep
- D:** Drain connection G 1/4; 12 mm [0.47 in] deep
- E:**  $\varnothing 14.1$
- F:** 5 x M14 • 1.5
- H:** M10, 17 mm [0.67 in] deep
- not painted

## Dimensions

Wheel - Spigot diameter  $\varnothing 180$  mm - BC  $\varnothing 210$  mm

Type		TMTW 250	TMTW 315	TMTW 400	TMTW 470	TMTW 500	TMTW 630
L <sub>1</sub>	mm	250.1	259.4	269.9	278.1	269.9	283.9
	[in]	[9.85]	[10.21]	[10.63]	[10.95]	[10.63]	[11.18]
L <sub>2</sub>	mm	99.0	108.3	118.8	127.0	118.8	132.8
	[in]	[3.90]	[4.26]	[4.68]	[5.00]	[4.68]	[5.23]

### US version

Wheel - Spigot diameter  $\varnothing 180$  mm - BC  $\varnothing 210$  mm

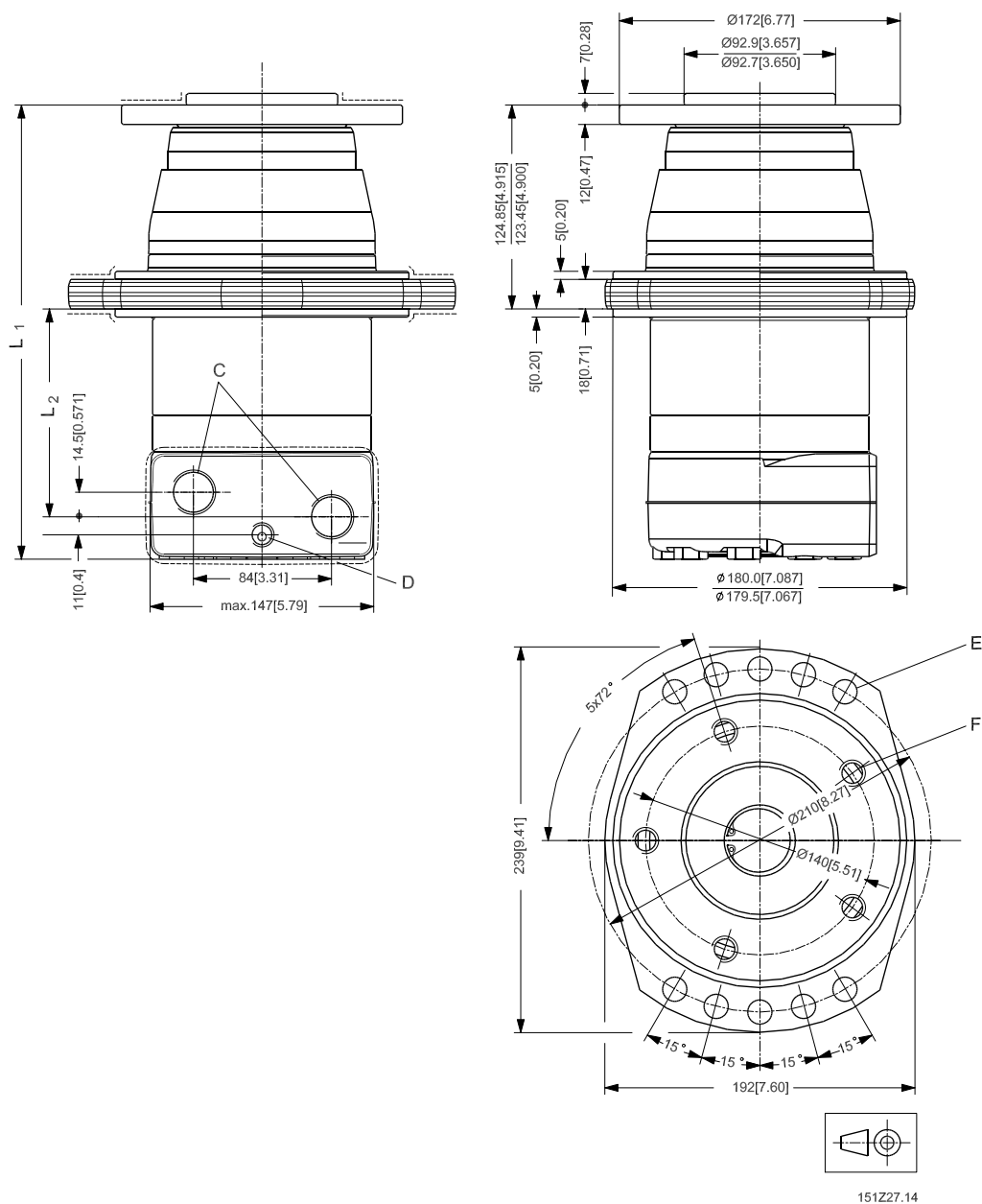

**C:** 1 1/16 - 12 UN O-ring boss port; 19 mm [0.75 in] deep

151Z27.14

**Dimensions**

**D:** Drain connection 9/16 - 18 UNF O-ring boss port; 12.7 mm [0.5 in] deep

**E:** Ø 14.1

**F:** 5 x M14 • 1.5

---- not painted

*Wheel - Spigot diameter Ø180 mm - BC Ø210 mm*

Type		TMTW 250	TMTW 315	TMTW 400	TMTW 470	TMTW 500	TMTW 630
L <sub>1</sub>	mm	250.1	259.4	269.9	278.1	269.9	283.9
	[in]	[9.85]	[10.21]	[10.63]	[10.95]	[10.63]	[11.18]
L <sub>2</sub>	mm	99.0	108.3	118.8	127.0	118.8	132.8
	[in]	[3.90]	[4.26]	[4.68]	[5.00]	[4.68]	[5.23]

**Dimensions**

**TMTW FL dimensions**

**US version**

Wheel - Spigot diameter  $\varnothing 160$  mm - BC  $\varnothing 194$  mm

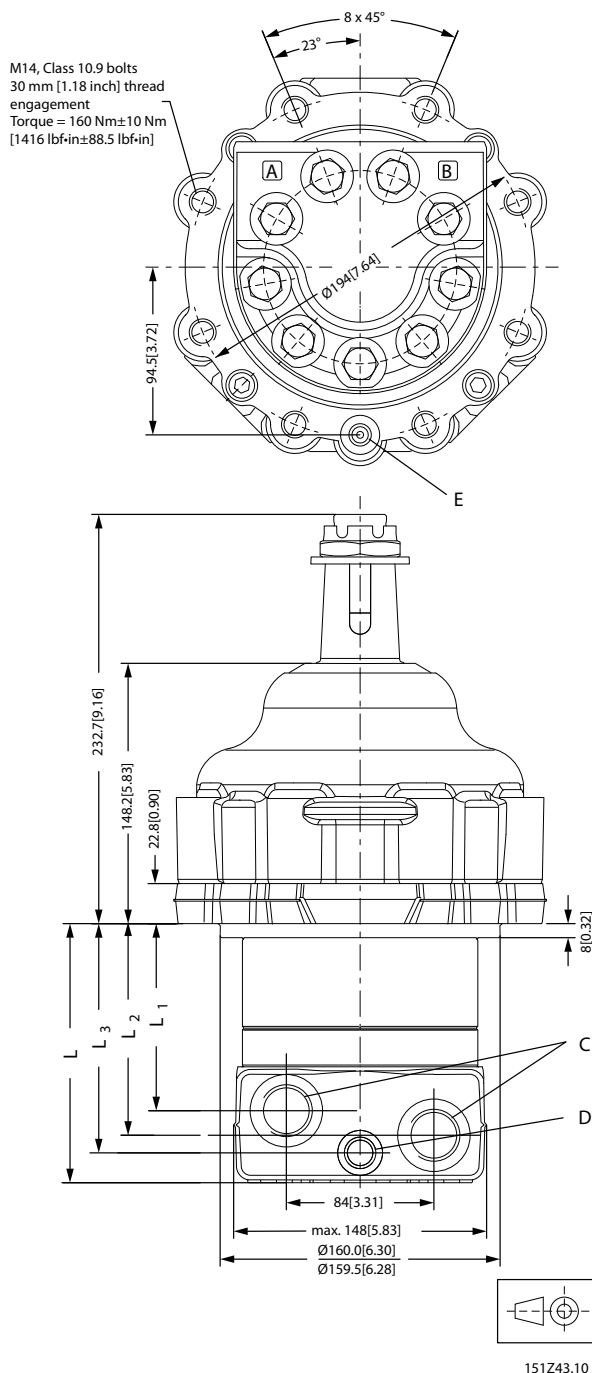

- C:** 1 1/16 - 12 UN O-ring boss port; 19 mm [0.75 in] deep
- D:** Drain connection 9/16 - 18 UNF O-ring boss port; 12.7 mm [0.5 in] deep
- E:** Release port; 7/16 - 20 UNF, 13 mm [0.51 in] deep

**Dimensions**

*Wheel - Spigot diameter Ø160 mm - BC Ø194 mm*

<b>Type</b>		<b>TMTW 250 FL</b>	<b>TMTW 315 FL</b>	<b>TMTW 400 FL</b>	<b>TMTW 500 FL</b>	<b>TMTW 630 FL</b>
L	mm	131.0	140.2	150.7	150.7	164.7
	[in]	[5.16]	[5.52]	[5.93]	[5.93]	[6.48]
L <sub>1</sub>	mm	86.8	96.0	106.5	106.5	120.5
	[in]	[3.42]	[3.78]	[4.19]	[4.19]	[4.74]
L <sub>2</sub>	mm	101.3	110.5	121.0	121.0	135.0
	[in]	[3.99]	[4.35]	[4.76]	[4.76]	[5.31]
L <sub>3</sub>	mm	[4.35]	120.0	130.5	130.5	144.5
	[in]	[4.36]	[4.72]	[5.14]	[5.14]	[5.69]

## Weight of motors

### Weight of TMT, TMTU, TMTW, TMT FL and TMTW FL orbital motors

Code number	Weight	
	kg	[lb]
151Z3000	16.1	[35.49]
151Z3001	16.9	[37.26]
151Z3002	17.8	[39.24]
151Z3003	18.5	[40.79]
151Z3004	19.0	[41.89]
151Z3005	19.0	[41.89]
151Z3010	25.2	[55.56]
151Z3011	26.1	[57.54]
151Z3012	27.1	[59.75]
151Z3013	27.8	[61.29]
151Z3014	28.4	[62.61]
151Z3015	28.4	[62.61]
151Z3016	22.5	[49.60]
151Z3017	23.3	[51.37]
151Z3018	24.3	[53.57]
151Z3020	25.2	[55.56]
151Z3021	26.1	[57.54]
151Z3022	27.1	[59.75]
151Z3023	27.8	[61.29]
151Z3024	28.4	[62.61]
151Z3025	28.4	[62.61]
151Z3026	22.5	[49.60]
151Z3027	23.3	[51.37]
151Z3028	24.3	[53.57]
151Z3030	25.2	[55.56]
151Z3031	26.1	[57.54]
151Z3032	27.1	[59.75]
151Z3033	27.8	[61.29]
151Z3034	28.4	[62.61]
151Z3035	28.4	[62.61]
151Z3036	22.5	[49.60]
151Z3037	23.3	[51.37]
151Z3038	24.3	[53.57]
151Z3040	35.3	[77.82]
151Z3041	36.2	[79.81]
151Z3042	37.2	[82.01]
1513Z043	38.0	[83.78]
151Z3044	38.5	[84.88]
151Z3045	38.5	[84.88]
151Z3050	35.3	[77.82]

**Weight of motors**

Code number	Weight	
	kg	[lb]
151Z3051	36.2	[79.81]
151Z3052	37.2	[82.01]
151Z3053	38.0	[83.78]
151Z3054	38.5	[84.88]
151Z3055	38.5	[84.88]
151Z3060	23.9	[52.69]
151Z3061	24.7	[54.45]
151Z3062	25.7	[56.66]
151Z3063	26.5	[58.42]
151Z3064	27.0	[59.52]
151Z3065	27.0	[59.52]
151Z3070	23.9	[52.69]
151Z3071	24.7	[54.43]
151Z3072	25.7	[56.66]
151Z3073	26.5	[58.42]
151Z3074	27.0	[59.52]
151Z3075	27.0	[59.52]
151Z3080	23.9	[52.69]
151Z3081	24.7	[54.45]
151Z3082	25.7	[56.66]
151Z3083	26.5	[58.42]
151Z3084	27.0	[59.52]
151Z3085	27.0	[59.52]
151Z3090	36.7	[80.91]
151Z3091	37.6	[82.89]
151Z3092	38.6	[85.10]
151Z3093	39.4	[86.86]
151Z3094	39.9	[87.96]
151Z3095	39.9	[87.96]
151Z3100	16.1	[35.49]
151Z3101	16.9	[37.26]
151Z3102	17.8	[39.24]
151Z3103	18.5	[40.79]
151Z3104	19.0	[41.89]
151Z3105	19.0	[41.89]
151Z3110	39.5	[87.08]
151Z3111	40.4	[89.07]
151Z3112	41.4	[91.27]
151Z3113	42.2	[93.03]
151Z3114	42.7	[94.14]
151Z3115	42.7	[94.14]
151Z3120	39.5	[87.08]



**Weight of motors**

Code number	Weight	
	kg	[lb]
151Z3121	40.4	[89.07]
151Z3122	41.4	[91.27]
151Z3123	42.2	[93.03]
151Z3124	42.7	[94.14]
151Z3125	42.7	[94.14]
151Z3130	39.5	[87.08]
151Z3131	40.4	[89.07]
151Z3132	41.4	[91.27]
151Z3133	42.2	[93.03]
151Z3134	42.7	[94.14]
151Z3135	42.7	[94.14]
151Z3229	27.6	[60.85]
151Z3230	28.4	[62.61]
151Z3231	29.3	[64.60]
151Z3232	30.0	[66.14]
151Z3233	30.5	[67.24]
151Z3234	30.5	[67.24]
151Z3273	27.6	[60.85]
151Z3274	28.4	[62.61]
151Z3275	29.3	[64.60]
151Z3276	30.0	[66.14]
151Z3277	30.5	[67.24]
151Z3278	30.5	[67.24]
11033926	41.2	[90.83]
11033927	41.2	[90.83]





#### Products we offer:

- Bent Axis Motors
- Closed Circuit Axial Piston Pumps and Motors
- Displays
- Electrohydraulic Power Steering
- Electrohydraulics
- Hydraulic Power Steering
- Integrated Systems
- Joysticks and Control Handles
- Microcontrollers and Software
- Open Circuit Axial Piston Pumps
- Orbital Motors
- PLUS+1® GUIDE
- Proportional Valves
- Sensors
- Steering
- Transit Mixer Drives

**Danfoss Power Solutions** is a global manufacturer and supplier of high-quality hydraulic and electronic components. We specialize in providing state-of-the-art technology and solutions that excel in the harsh operating conditions of the mobile off-highway market. Building on our extensive applications expertise, we work closely with our customers to ensure exceptional performance for a broad range of off-highway vehicles.

We help OEMs around the world speed up system development, reduce costs and bring vehicles to market faster.

Danfoss – Your Strongest Partner in Mobile Hydraulics.

**Go to [www.powersolutions.danfoss.com](http://www.powersolutions.danfoss.com) for further product information.**

Wherever off-highway vehicles are at work, so is Danfoss. We offer expert worldwide support for our customers, ensuring the best possible solutions for outstanding performance. And with an extensive network of Global Service Partners, we also provide comprehensive global service for all of our components.

Please contact the Danfoss Power Solution representative nearest you.

#### Comatrol

[www.comatrol.com](http://www.comatrol.com)

#### Schwarzmueller-Inverter

[www.schwarzmueller-inverter.com](http://www.schwarzmueller-inverter.com)

#### Turolla

[www.turollaocg.com](http://www.turollaocg.com)

#### Hydro-Gear

[www.hydro-gear.com](http://www.hydro-gear.com)

#### Daikin-Sauer-Danfoss

[www.daikin-sauer-danfoss.com](http://www.daikin-sauer-danfoss.com)

Local address:

**Danfoss Power Solutions (US) Company**  
2800 East 13th Street  
Ames, IA 50010, USA  
Phone: +1 515 239 6000

**Danfoss Power Solutions GmbH & Co. OHG**  
Krokamp 35  
D-24539 Neumünster, Germany  
Phone: +49 4321 871 0

**Danfoss Power Solutions ApS**  
Nordborgvej 81  
DK-6430 Nordborg, Denmark  
Phone: +45 7488 2222

**Danfoss Power Solutions Trading (Shanghai) Co., Ltd.**  
Building #22, No. 1000 Jin Hai Rd  
Jin Qiao, Pudong New District  
Shanghai, China 201206  
Phone: +86 21 3418 5200

Danfoss can accept no responsibility for possible errors in catalogues, brochures and other printed material. Danfoss reserves the right to alter its products without notice. This also applies to products already on order provided that such alterations can be made without changes being necessary in specifications already agreed. All trademarks in this material are property of the respective companies. Danfoss and the Danfoss logotype are trademarks of Danfoss A/S. All rights reserved.