

MG11 MGE11

STEERABLE WHEEL MOTOR

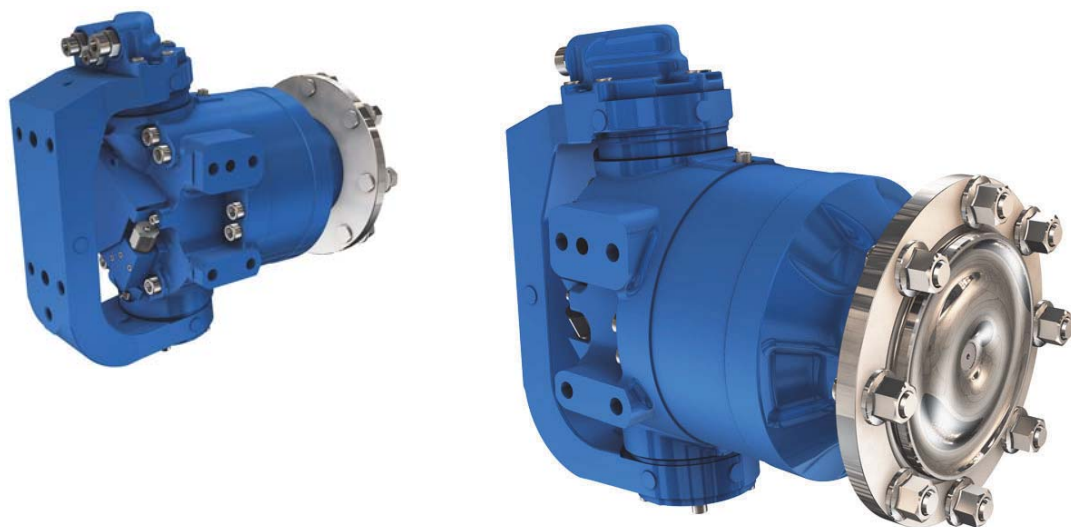

T E C H N I C A L C A T A L O G

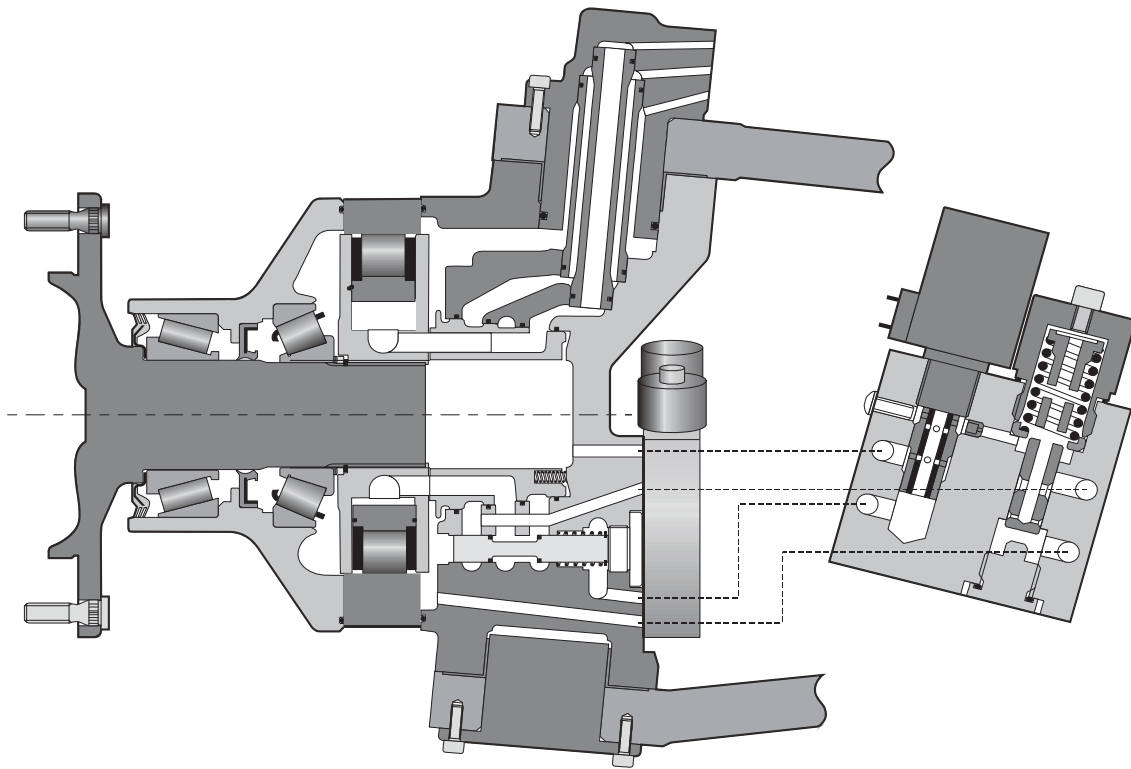

Motor Inertia : 0.05 kg.m²

	Displacement		Theoretical torque		Max.power			Max. speed		Max. pressure	
	①	②	①		①	②		①	②		
	cm ³ /tr [cu.in./rev.]	cm ³ /tr [cu.in./rev.]	at 100 bar Nm	at 1000 PSI [lb.ft]	kW [HP]	preferred kW [HP]	non-preferred kW [HP]	tr/min	[RPM]		
Cams with equal lobes	MG11	7	730 [44,5]	365 [22,3]	1 161	[590]			200		
		8	837 [51,0]	419 [25,5]	1 331	[677]			195		
		9	943 [57,5]	472 [28,8]	1 499	[762]			190		
		0	1 048 [63,9]	524 [32,0]	1 666	[847]			185	450 [6 530]	
		1	1 147 [70,0]	574 [35,0]	1 824	[927]	50 [67]	33 [44]	25 [34]	180	
		2	1 259 [76,8]	630 [38,4]	2 002	[1 018]				170 175	
	MGE11	9	1 263 [77,0]	632 [38,5]	2 008	[1 021]				170 190	
		0	1 404 [85,6]	702 [42,8]	2 232	[1 135]				155 185	400 [5 800]
		1	1 536 [93,7]	768 [46,8]	2 442	[1 242]				140 180	
		2	1 687 [102,9]	844 [51,4]	2 682	[1 364]				130 165	
Cams with unequal lobes	MG11	A	1 048 [63,9]	629 [38,4]	1 666	[847]	50 [67]	33 [44]	25 [34]	170	450 [6 530]
			419 [25,6]								
	MGE11	A	1 404 [85,6]	843 [51,4]	2 232	[1 135]				120	400 [5 800]
			561 [34,2]								

- ① First displacement
- ② Second displacement



CONTENT

MODEL CODE **5**

Model code

CHARACTERISTICS **6**

Standard (1910) single displacement motor with built-in exchange	6
Standard (1910) 2 displacement motor with built-in exchange	7
Exchange	7
Load curves	8
Efficiency	9
Wheel rim mountings	10
Chassis mounting	10
Steering attachment	11
Steering angle	11
Hydraulic connections	12

Characteristics

OPTIONS **13**

Options



Methodology :

This document is intended for manufacturers of machines that incorporate Poclairn Hydraulics products. It describes the technical characteristics of Poclairn Hydraulics products and specifies installation conditions that will ensure optimum operation. This document includes important comments concerning safety. They are indicated in the following way:



Safety comment.

This document also includes essential operating instructions for the product and general information. These are indicated in the following way:



Essential instructions.



General information .



Information on the model number.Information on the model code.



Weight of component without oil.



Volume of oil.



Units.



Tightening torque.



Screws.



Information intended for Poclairn-Hydraulics personnel.

The views in this document are created using metric standards.

The dimensional data is given in mm and in inches (inches are between brackets and italic)





MODEL CODE

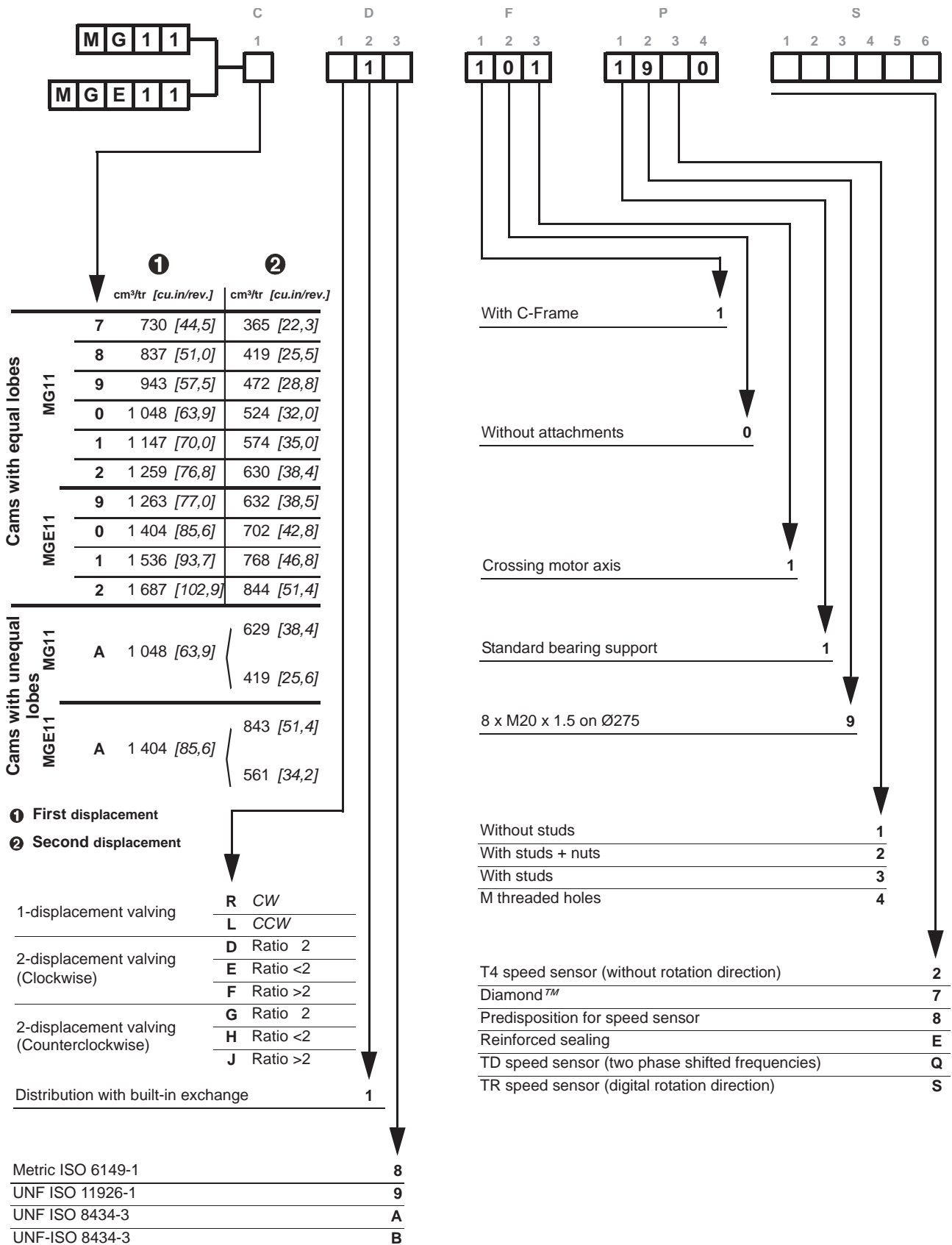



CHARACTERISTICS

Standard (1910) single displacement motor with built-in exchange

	210 kg [462 lb]
	1,00 L [60 cu.in]

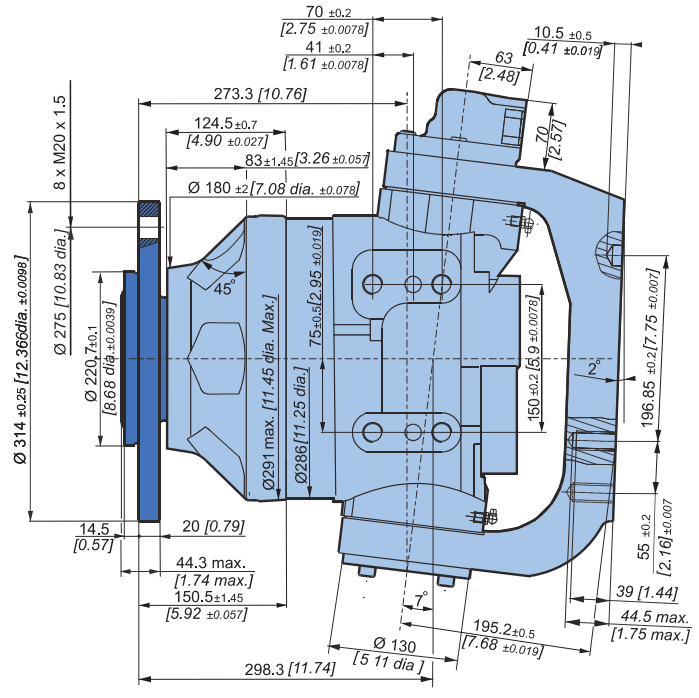
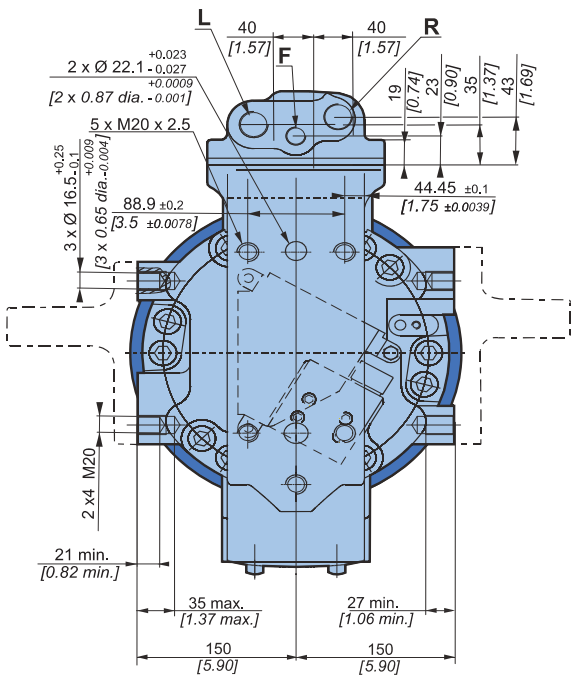



Standard (1910) 2 displacement motor with built-in exchange

	210 kg [462 lb]
	1,00 L [60 cu.in]

Model code

Characteristics

Options

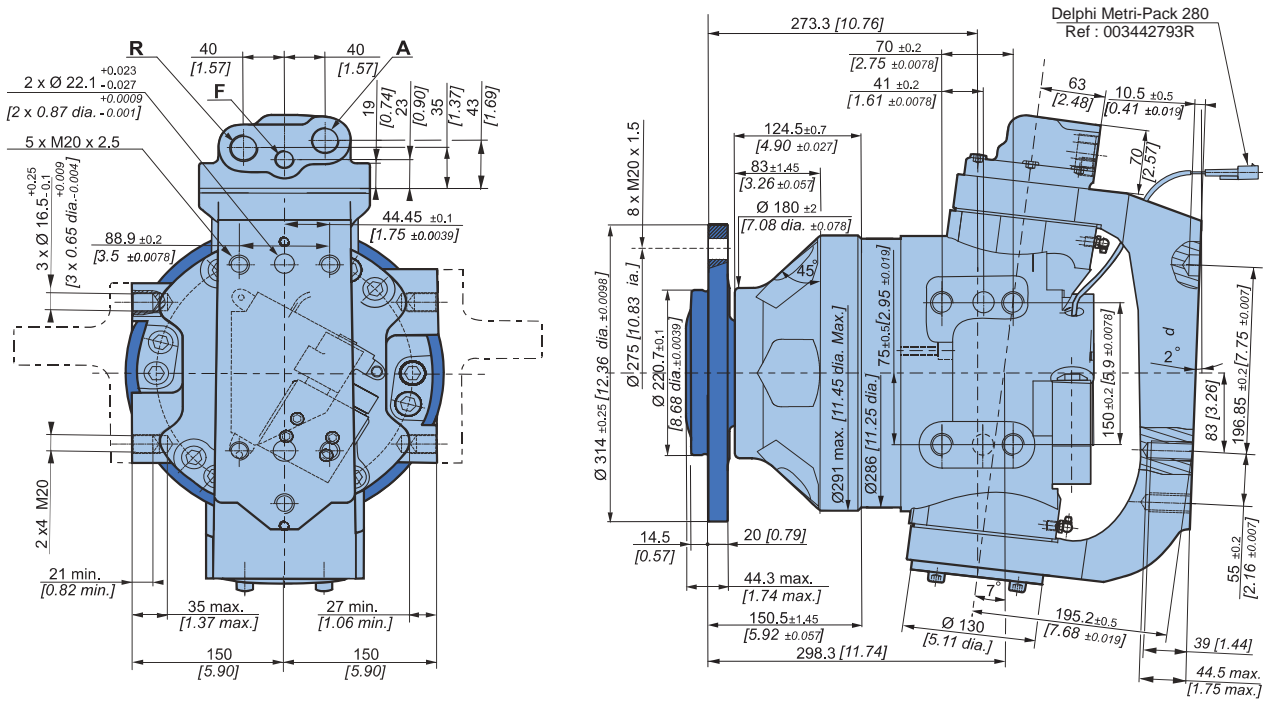

Exchange

When a coding request is made, you must specify information on the threshold of the selector and the valve.

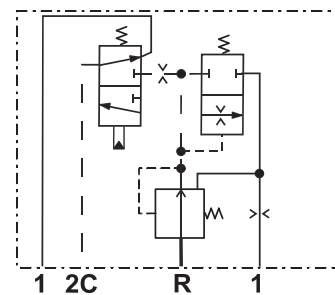
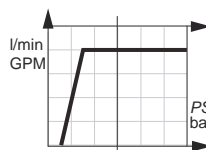
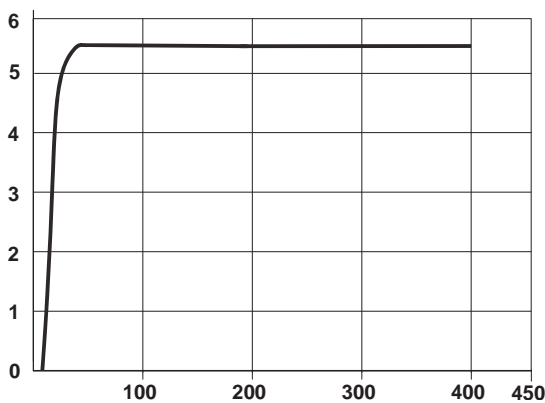

The exchange flow rate indicated on the basis of the supply pressure (P = 50 bar [725 PSI]) is constant (Q = 5.5 l/min [1.45 GPM]).



Load curves



The given load curves correspond to the conditions specified below. For load curves corresponding to your specifications, contact a Poclair Hydraulics engineer.

Permissible radial loads

Test conditions :

Static :

- 150 bar [2175 PSI], code 9 displacement
- Max. axial stress = 15% of Fr
- Load radius = 719 mm [28.31 in]

Dynamic :

- 450 bar [6527 PSI], code 9 displacement
- Max. axial stress = 15% of Fr
- Load radius = 719 mm [28.31 in]

MG11

Service life of bearings

Test conditions :

L : Millions B10 revolutions at 150 bars (average pressure), with 25 cSt fluid, code 2 displacement, without axial load.

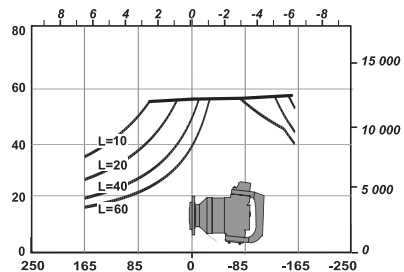
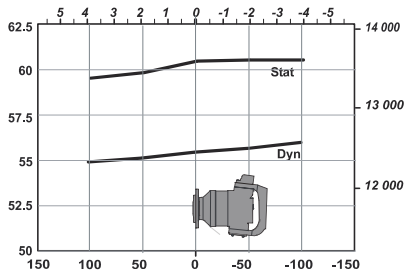
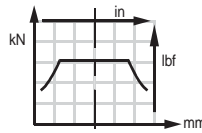

Permissible radial loads

Test conditions :

Static :

- 150 bar [2175 PSI], code 9 displacement
- Max. axial stress = 15% of Fr
- Load radius = 719 mm [28.31 in]

Dynamic :

- 450 bar [6527 PSI], code 9 displacement
- Max. axial stress = 15% of Fr
- Load radius = 719 mm [28.31 in]

MGE11

Service life of bearings

Test conditions :

L : Millions B10 revolutions at 150 bars (average pressure), with 25 cSt fluid, code 0 displacement, without axial load.

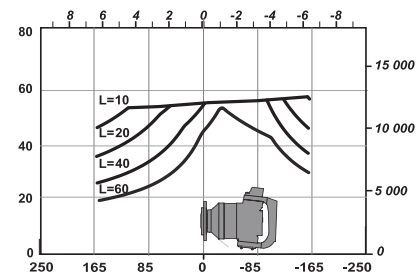
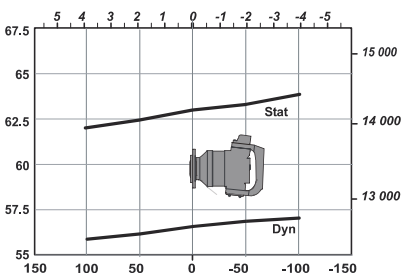
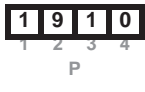
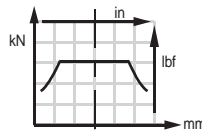

The service life of the components is influenced by the pressure. You must check that the combination of forces applied (Axial load / Radial load) is compatible with the permissible loads for the components, and that the resulting service lives of these components complies with the application's specifications. For an accurate calculation, consult your Poclair Hydraulics application engineer.

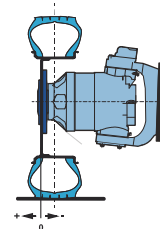



Efficiency

Overall efficiency

Average values given for guidance for code 0 displacement after 100 hours of operation with HV46 hydraulic fluid at 50°C [122°F].

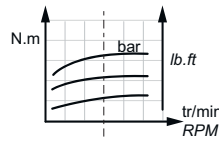
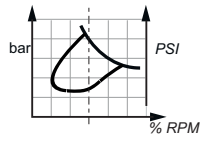

Actual output torque

MG11

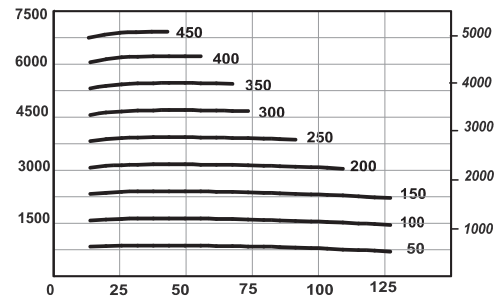
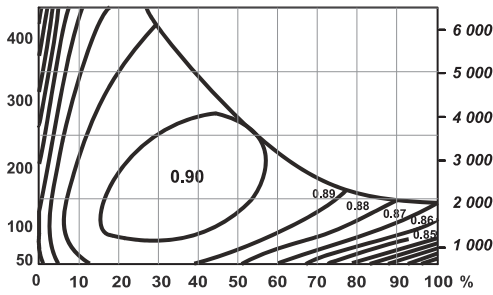

MGE11

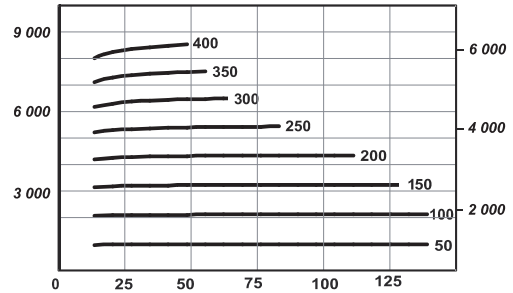
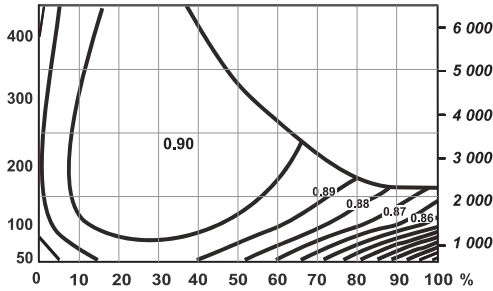

For a precise calculation, consult your Poclain Hydraulics application engineer.

Model code

Characteristics

Options



Wheel rim mountings

	Class
8xM20x1.5	12,9



See generic installation motors N°801478197L.

Chassis mounting

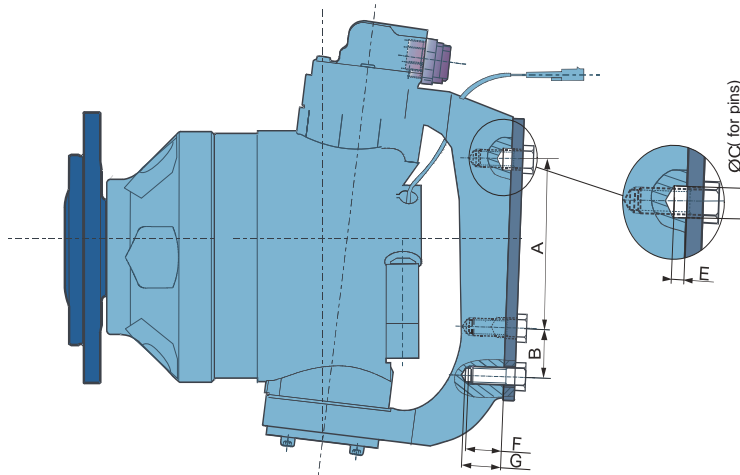

Take care over the immediate environment of the connections.

A (1) mm [in]	B (1) mm [in]	2xØC (2) mm [in]	E (3) mm [in]	F max. mm [in]	G (4) mm [in]
196,85 [7,75]	55 [2,17]	22,1 [0,87]	10,5 [0,41]	39 [1,54]	44,5 [1,75]

	Class	 (*)
5xM20x2.5	12.9	N.m [lb.ft] 690 [509]

- (1) + 0.2 [+0.0078]
- 0.2 [- 0.0078]
- (2) + 0.023 [+0.0009]
- 0.0027 [- 0.0010]
- (3) + 0.5 [+0.019]
- 0.5 [- 0.019]

(*) The tightening torques are given for the indicated loads.



Pins are used to take tangential stress.



Steering attachment

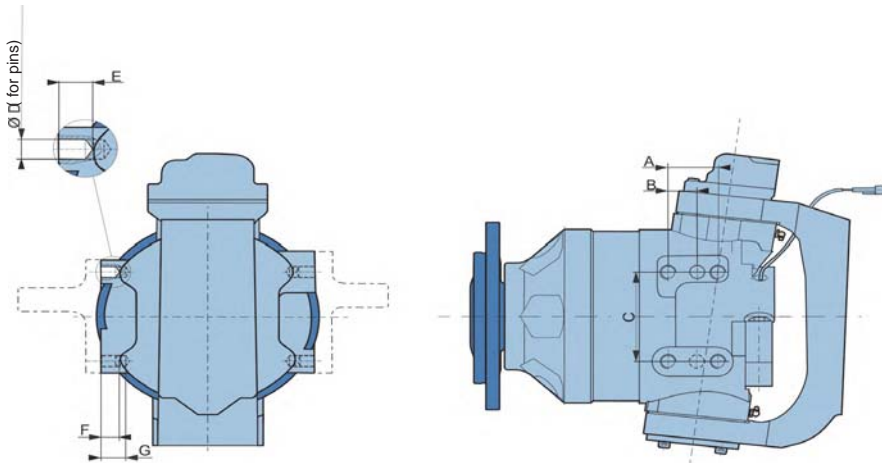

A (1) mm [in]	B (1) mm [in]	C (1) mm [in]	3x ØD (2) mm [in]	E mm [in]	F mm [in]	G mm [in]
70 [2,76]	41 [1,61]	150 [5,91]	16,5 [0,65]	27 [1,06]	21 [0,83]	35 [1,38]

Class	(*)	
	N.m	[lb.ft]
8x M20x2.5	12,9	690 [509]
(1) + 0.2 [+0.0078] - 0.2 [- 0.0078]	(2) + 0.25 [+0.0098] - 0.1 [- 0.0039]	

(*) The tightening torques are given for the indicated loads.



Pins are used to take tangential stress.

Steering angle

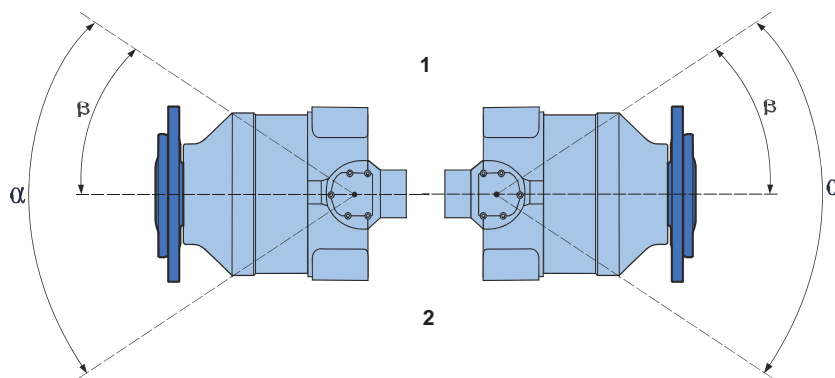

Attachment(s)	α	β
	Max.	Min.
1	80 °	40 °
2	74 °	37 °

Model code

Characteristics

Options



Hydraulic connections

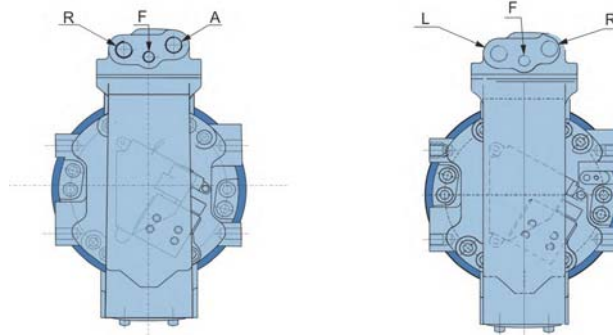

	Standards	Power supply		Case drain
		Single displacement motor R,L	Double displacement motor A,R	F
A	ISO 11926-1	1" 1/16 12 UNF	1" 1/16 12 UNF	3/4" 16 UNF
8	ISO 6149-1	-	M27 x 2	M18 x 1.5



You are strongly advised to use the fluids specified in brochure "Installation guide" N° 801478197L.



To find the connections' tightening torques, see the brochure "Installation guide" N° 801478197L.



OPTIONS

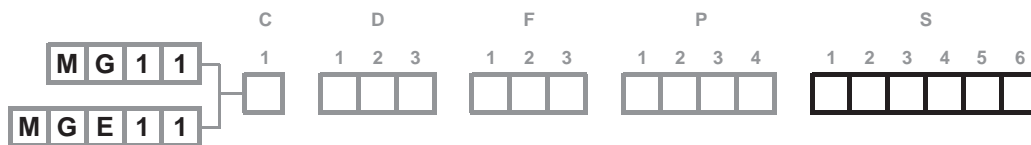

You can accumulate more than one optional part. Consult your Poclair Hydraulics sales engineer.

2 - S - Q - 8 - Installed speed sensor or predisposition

Designation	C
T4 speed sensor (without rotation direction)	2
TR speed sensor (digital rotation direction)	S
TD speed sensor (two phase shifted frequencies)	Q
Predisposition for speed sensor	8

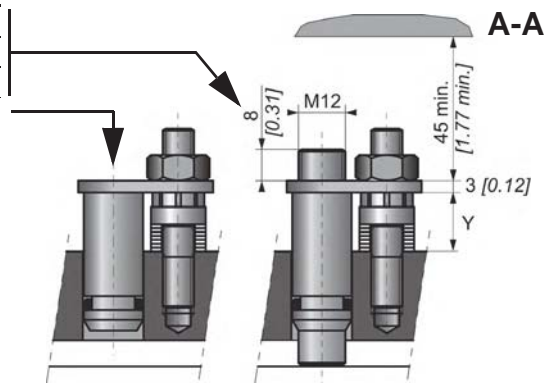
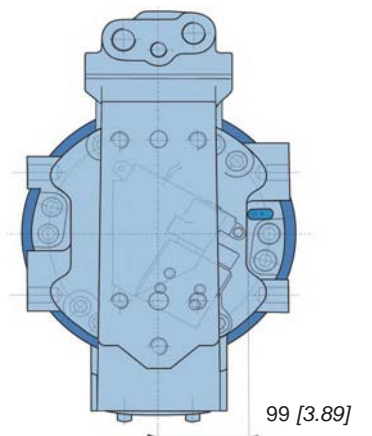

Max. length Y= 13.5
Standard number of pulses per revolution= 56



Look at the "Mobile Electronic" N° A01889D technical catalogue for the sensor specifications and its connection.



To install the sensor, see the "Installation guide" brochure No. 801478197L.

7 - Diamond™

Special treatment of the motor core which considerably increases its strength, making the motor much more tolerant to temporary instances of the operating conditions being exceeded.

E - Reinforced sealing

Requires reinforcement of shaft bearings.

Model code

Characteristics

Options





Model code

Characteristics

Options



Poclain Hydraulics reserves the right to make any modifications it deems necessary to the products described in this document without prior notification. The information contained in this document must be confirmed by Poclain Hydraulics before any order is submitted.

Illustrations are not binding.

The Poclain Hydraulics brand is the property of Poclain Hydraulics S.A.

 11/01/2018

 A04197M

 A04203T

 Not available

 Not available

 Not available

 B33975D

 Not available

 Not available

