

Series D Hydraulic Gear Pumps

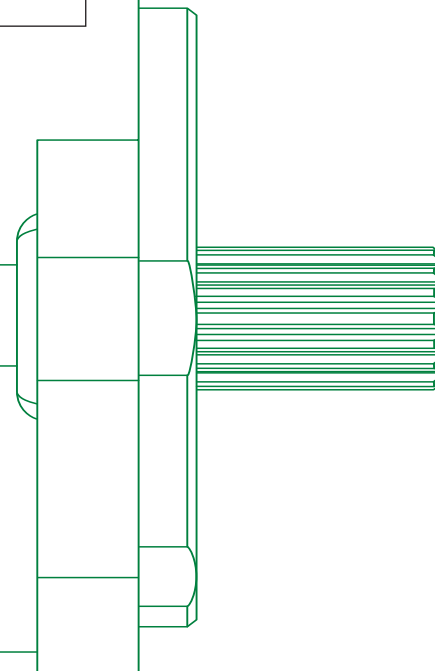

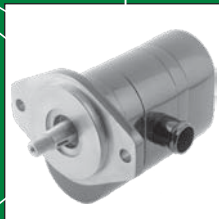
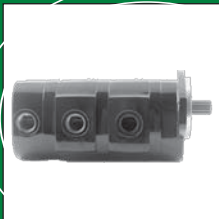
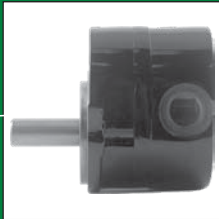
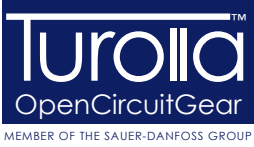

Series D Hydraulic Gear Pumps Technical Manual Revisions

History of Revisions

Table of Revisions

Date	Page	Changed	Rev.
Jun, 2010	-	First edition	A

© 2010 Turolla OpenCircuitGear™. All rights reserved.

Turolla OCG accepts no responsibility for possible errors in catalogs, brochures and other printed material. Turolla OCG reserves the right to alter its products without prior notice. This also applies to products already ordered provided that such alterations can be made without affecting agreed specifications. All trademarks in this material are properties of their respective owners. Sauer-Danfoss, Turolla, Turolla OpenCircuitGear, Turolla OCG, OpenCircuitGear, Fast Lane and PLUS+1 are trademarks of the Sauer-Danfoss Group.

Front cover illustrations: F101 209, F101 212, F101 217, F101 449, F101 210, F101 211, F101 215, F101 214, F101 213, P104 323

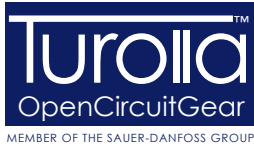

Series D Hydraulic Gear Pumps Technical Manual

General information

Overview	4
Construction	5
One piece gear construction	5
Sealing	5
Pressure balanced deflecting plate	5
Advantages	5
Product features	6
Ratings and dimensions	7

Model code / nomenclature

Order code	8
------------------	---

Technical specifications

Mounting flanges	17
Shaft options.....	19
Drive shaft torque limits	20
Port options.....	21
SAE O-ring	21
Valve options	22
Fixed priority flow valve	22
Pumps with priority flow dividers.....	23
Valve options	24
Load sense priority flow valve.....	24
Pumps with load sense priority flow valves	25

Performance data

Flow performance.....	26
-----------------------	----

System specifications

Operating parameters	31
Line sizing	31
Inlet pressure.....	31
Rated pressure	31
Peak pressure	31
Maximum speed ratings.....	31
Minimum speed ratings	31
Fluids	32
Temperature	32
Viscosity.....	32
Filtration	33
Reservoir	33
Pump drives.....	34
Pump drive.....	34
Plug-in drives.....	34

Series D Hydraulic Gear Pumps

Technical Manual

General information

Overview

The D Series pumps have an excellent reputation for rugged, dependable performance at continuous pressures to 276 bar [4000 psi] and speeds to 3400 min⁻¹ (rpm). Typical noise level is less than 75 dB(A) under normal operating conditions.

The D Series pumps provide tremendous design flexibility. They have standard displacements from 7 to 45 cm³/rev [.43 to 2.75 in³/rev]; splined, keyed, and tapered shaft drive options; SAE porting; and integral valve options that can be used in virtually any combination to create a pumps that meet specific application requirements.

The cast iron housings that comprise the pump structural members provide the strength needed for rugged applications. The front mounting flange and cover are ductile iron members that incorporate, and solidly support, the heavy-duty journal bearings. These bearings are state-of-the-art steel-backed bronze, developed for just the type of pressure the D pumps can handle. The center gear plate section (also made of ductile iron) is the main pressure vessel of the pump, and is designed for maximum strength.

Quality components and construction

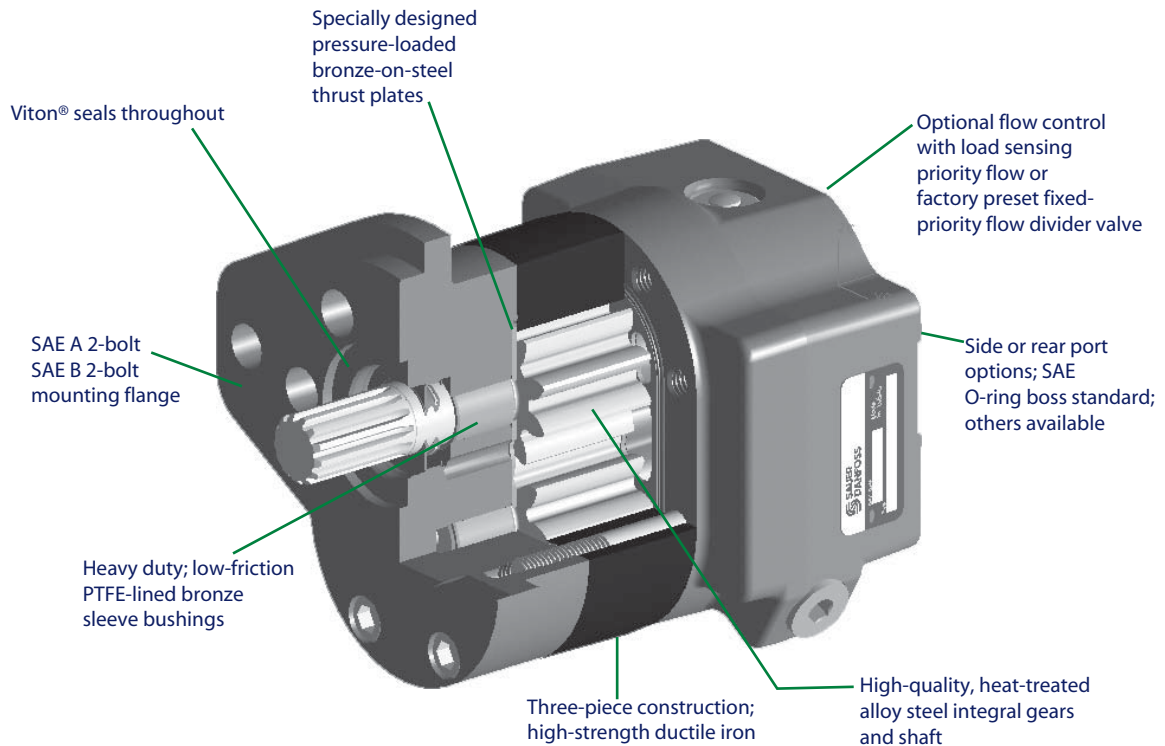

F101 450E

Construction

One piece gear construction

All D Series pump gear shafts are of one-piece construction. This enables the shaft to provide uniform high strength and accurate gear profile relative to the journals for smooth mesh operation. This design controls all gear tolerances, in particular total radial run-out of the gear and gear face parallelism. The integral gear shafts are constructed of heat-treated AISI 8620 steel manufactured to precise tolerances and surface finishes for maximum life and minimal leakage. This integral design eliminates the potential problems of fatigue stress and gear face mismatch often associated with two-piece gear shaft designs.

Sealing

An important feature of all modern hydraulic gear pumps is the method of sealing the sides of the rotating gears for efficient operation over a wide temperature range. The fixed clearance gear pump, which has benefits of its own, has long been discounted for most applications requiring high efficiency, since only very close clearance can control side leakage paths.

The D Series pump sealing function incorporates steel-backed bronze deflecting plates, which fit into conforming depressions in the mounting flange and cover (and in the bearing plate for multiple pumps). The deflecting plates seal the sides of the gears. The key to this function is the pressure-loading load seal underneath one plate on the mounting flange side. The pressure-loading seal, incorporating a Viton[®] elastomeric element and a flexible anti-extrusion element, allows discharge pressure underneath the plate to balance the pressure distribution in the gear tooth spaces, with a slight overbalance to keep the thrust plates sealing against the sides of the gears.

Pressure balanced deflecting plate

This design, often called a *deflecting-plate* gear pump, offers pressure balanced side of the gears in a compact package size. The deflecting plates provide uniform side sealing of the gears over the wide range of pressures and temperatures. The deflecting plates are constructed of steel-backed bronze.

Advantages

- **Up to 276 bar [4000 psi]** operating pressure
- **Power density:** 20% smaller envelope size than conventional pumps
7 to 45 cm³ [.43 to 2.75 in³/rev] in one frame size
- **Flexibility:** Integral valve options, multiple sections, and reduced or common inlets for numerous configurations
- **High Efficiency:** 96% volumetric, 90% overall

Product features

Features	Description
Construction	Heavy duty ductile iron 3-piece construction
Displacements	7 to 45 cm ³ [0.43 to 2.75 in ³ /rev]
Pressure (inlet)	0.8 bar absolute [6.3 in Hg] recommended, 0.6 bar abs. [12.2 in Hg vac.] cold start
Pressure (outlet)	276 bar [4000 psi] to 32.8 cm ³ [1.94 in ³ /rev]
Speed	600 - 3400 min min ⁻¹ (rpm)
Mounting	SAE-A, SAE-B, Perkins® engine mount and specials available upon request.
Shaft (types)	SAE splined, keyed, tapered, and specials available upon request.
Axial / radial load	Contact Turolla OCG Technical Support
Fluid viscosity	10 mm ² /sec (cSt) [60 SUS] minimum, 1600 mm ² /sec (cSt) [7500 SUS] maximum
Filtration requirement	22/18/13 ISO 4406 at pump inlet
Flow velocity	4.3 m/sec [14 ft/sec] maximum inlet velocity and 8 m/sec [26 ft/sec] maximum recommended discharge velocity
Multiple configuration	Single, double, triple, and quadruple configurations
Inlet options	Single or reduced inlet options
Fluids	Mineral based and biodegradable fluids
Operating temperature	-30°C [-20°F] minimum for cold start 82°C [180°F] normal operating conditions 104°C [220°F] peak intermittent

Ratings and dimensions

Ratings	Units	07	10	13	14	17	19	21	23	25	29	32	36	38	41	45
Displacement	cm ³ /rev	7.0	9.5	12.6	14.3	17.0	19.0	20.5	22.5	25.4	29.0	31.8	36.0	38.0	41.0	45.1
	in ³ /rev	0.43	0.58	0.77	0.87	1.04	1.16	1.25	1.37	1.55	1.77	1.94	2.20	2.32	2.50	2.75
Rated pressure	bar	276	276	276	276	276	276	276	276	276	276	276	241	228	207	190
	psi	4000	4000	4000	4000	4000	4000	4000	4000	4000	4000	4000	3500	3300	3000	2750
Peak pressure	bar	303	303	303	303	303	303	303	303	303	303	303	265	250	228	209
	psi	4400	4400	4400	4400	4400	4400	4400	4400	4400	4400	4400	3850	3630	3300	3025
Speed min ⁻¹ (rpm)	maximum	3400	3400	3400	3400	3400	3400	3400	3400	3400	3200	3000	2750	2750	2500	2500
	minimum	1200	900	700	700	600	600	600	600	600	600	600	600	600	600	600
Theoretical flow at max speed	l/min	24.0	32.3	42.9	48.5	57.9	64.6	69.6	76.3	86.4	92.8	95.4	99.0	104.5	102.4	112.7
	US gal/min	6.3	8.5	11.3	12.8	15.3	17.1	18.4	20.2	22.8	24.5	25.2	26.2	27.6	27.1	29.8
Weight	kg	7.2	7.3	7.5	7.6	7.8	7.9	7.9	8.1	8.3	8.4	8.6	8.8	9.0	9.1	9.4
	lb	15.8	16.1	16.5	16.7	17.1	17.4	17.5	17.8	18.2	18.6	19.0	19.6	19.8	20.2	20.7
Mass moment of inertia	x10 ⁻⁶ kg·m ²	56	66	79	85	97	105	111	119	132	147	158	176	184	196	213
	x10 ⁻⁶ slug·ft ²	41	48	58	63	71	77	82	88	97	108	117	130	136	145	157
Dimension A	mm	7.1	9.7	12.7	14.4	17.0	19.1	20.6	22.5	25.4	29.0	31.8	36.1	38.1	41.0	45.2
	in	0.28	0.38	0.50	0.57	0.67	0.75	0.81	0.88	1.00	1.14	1.25	1.42	1.50	1.61	1.78

Single pump dimensions

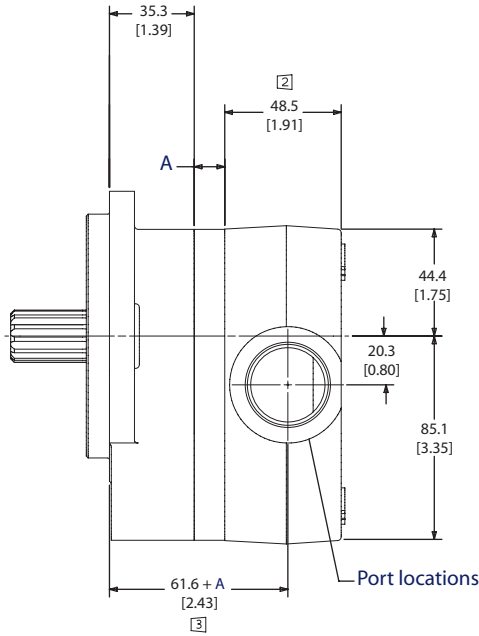

Multiple section pump dimensions

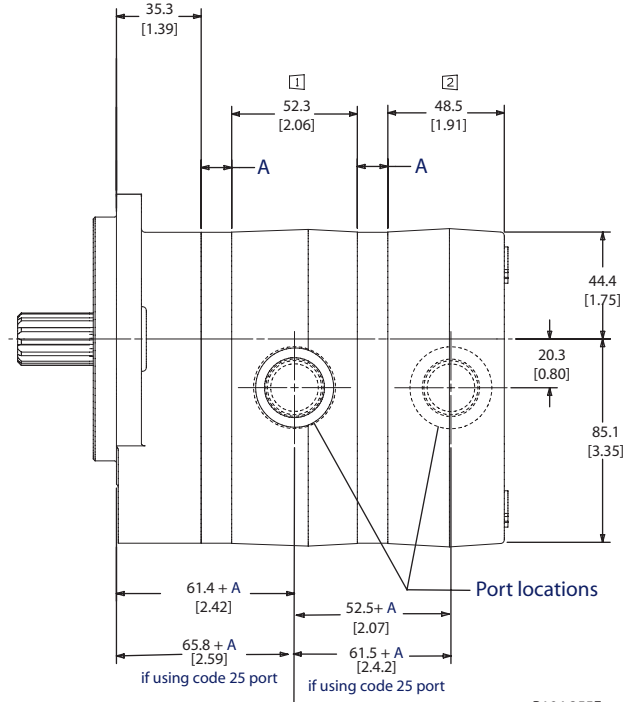

P104 255E

Noted values when using 1 5/8 SAE O-ring inlet port

- ❑ 61.2 mm [2.4 in]
- ❑ 63.5 mm [2.50 in]
- ❑ 66.3 mm [2.61 in]

Dimensions mm [in]

Order code

Single pumps



Tandem pumps



Example order code for single pumps

A	B	C	D	E	F	H	J	K
DE1L	25SH	BB	N104	NNN	000	AJ	AN	NNN

Example order code for tandem pumps

A	B	C	R	S	D	E	F	H	J	K
DE2L	25SH	BB	104	25	N104	NNN	000	AX	AN	NNN

For single pumps, R and S positions are omitted.

A1: Product

Code	Description
DE	D Series, revision level E

A2: Sections

Code	Description
1	Single section pump
2	Dual section pump

A3: Rotation

Code	Description
L	Left hand (counterclockwise)
R	Right hand (clockwise)

All available options are not shown in the model code. Please contact your Turolla OCG representative if your application requires an option not shown in the model code.

Order code
(continued)

Single pumps



Tandem pumps



B1: Displacement 1

Code	cm ³ / rev [in ³ / rev]
07	7.0 [0.43]
10	9.5 [0.58]
13	12.6 [0.77]
14	14.3 [0.87]
17	17.0 [1.04]
19	19.0 [1.16]
21	20.5 [1.25]

Code	cm ³ / rev [in ³ / rev]
23	22.5 [1.37]
25	25.4 [1.55]
29	29.0 [1.77]
32	31.8 [1.94]
38	38.0 [2.32]
41	41.0 [2.50]

B2: Input shaft

Code	Description
SC	SAE 11 tooth spline, 1.50 in length
SE	SAE 9 tooth spline, 1.25 in length
SF	11 tooth spline, 1.25 in length (special modified length)
SH	SAE 13 tooth spline, 1.62 in length
PB	22 mm (7/8 in) dia x 41 mm (1.62 in) length, with 1/4 in key
PD	19 mm (3/4 in) dia x 51 mm (2.0 in) length, with 3/16 in key

C: Mounting flange

Code	Description
AA	SAE-A 2 bolt
BB	SAE-B 2 bolt

R: Porting for front section of tandem pump (omit if single pump)

Code	Location	Port type	Inlet size	Outlet size
101	Radial	O-ring boss	1-1/16 in	7/8 in
104	Radial	O-ring boss	1-5/16 in	1-1/16 in
113	Radial	O-ring boss	NA	7/8 in
125	Radial	O-ring boss	1-5/8 in	1-1/16 in
126	Radial	O-ring boss	NA	1-1/16 in

All available options are not shown in the model code. Please contact your Turolia OCG representative if your application requires an option not shown in the model code.

Series D Hydraulic Gear Pumps

Technical Manual

Model code / nomenclature

Order code (continued)

Single pumps

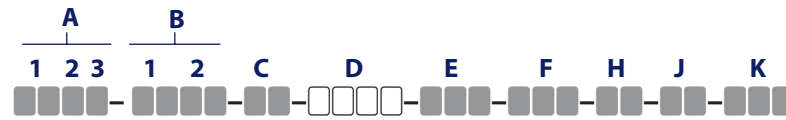

Tandem pumps

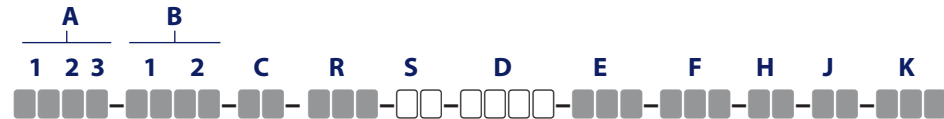

S: Rear displacement of tandem pump (omit if single pump)

Code	cm ³ / rev [in ³ / rev]
07	7.0 [0.43]
10	9.5 [0.58]
13	12.6 [0.77]
14	14.3 [0.87]
17	17.0 [1.04]
19	19.0 [1.16]
21	20.5 [1.25]
23	22.5 [1.37]
25	25.4 [1.55]
29	29.0 [1.77]
32	31.8 [1.94]
38	38.0 [2.32]
41	41.0 [2.50]

D: Rear cover port options

Code	Location	Port type	Inlet size	Outlet size
N101	Radial	O-ring boss	1-1/16 in	7/8 in
N104	Radial	O-ring boss	1-5/16 in	1-1/16 in
N113	Radial	O-ring boss	NA	7/8 in
N125	Radial	O-ring boss	1-5/8 in	1-1/16 in
N126	Radial	O-ring boss	NA	1-1/16 in
N504	Axial	O-ring boss	1-5/16 in	1-1/16 in

All available options are not shown in the model code. Please contact your Turolla OCG representative if your application requires an option not shown in the model code.

Series D Hydraulic Gear Pumps

Technical Manual

Model code / nomenclature

Order code
(continued)

Single pumps



Tandem pumps



E: Control setting

Code	Description
NNN	No controls

F: Relief valve setting

Code	Description
000	No relief valve setting

H: Screws

Use the following tables to determine the correct H position code for a D Series pump.

Single pumps, please refer to Table 1. Tandem pumps, refer to Table 2, 3, 4, or 5 on the following pages, depending on your port code positions.

Table number	Front pump port code (position R)	Rear pump port code (position D)
Table 2	101, 104, 113, or 126	N101, N104, N113, or N126
Table 3	125	N101, N104, N113, or N126
Table 4	101, 104, 113, or 126	N125
Table 5	125	N125

Table 1: Single pump screws

Displacement Code B1	Rear cover port option D	
	N101, N104, and N504	N125
07	AF	AJ
10	AG	AJ
13	AG	AJ
14	AG	AK
17	AH	AK
19	AH	AK
21	AH	AL
23	AJ	AL
25	AJ	AL
29	AK	AM
32	AK	AM
38	AL	AN
41	AM	AP

All available options are not shown in the model code. Please contact your Turolia OCG representative if your application requires an option not shown in the model code.

Order code
(continued)

Single pumps



Tandem pumps



H: Tandem pump screws

For tandem pumps with R position codes 101, 104, 113, or 126 and D position codes N101, N104, N504, N113, or N126, please refer to Table 2 below.

Table 2

Example: H position code for a 21+19 tandem with a 113 R position code and N104 D position = AW

Use this table for the following codes: R position codes :101, 104, 113, or 126 D position codes: N101, N104, N504, N113, or N126 This table cannot be used with R position 125 or D position N125													
Displacement Code B1 position	Rear displacement of multiple pumps (reference S position code)												
	07	10	13	14	17	19	21	23	25	29	32	38	41
07	AS	AS	AS	AT	AT	AT	AU	AU	AU	AV	AV	AW	AX
10	AS	AS	AT	AT	AU	AU	AU	AU	AV	AV	AW	AX	AX
13	AS	AT	AT	AU	AU	AU	AV	AV	AV	AW	AW	AX	AY
14	AT	AT	AU	AU	AU	AV	AV	AV	AW	AW	AX	AY	AY
17	AT	AU	AU	AU	AV	AV	AV	AW	AW	AX	AX	AY	AY
19	AT	AU	AU	AV	AV	AV	AW	AW	AW	AX	AX	AY	AZ
21	AU	AU	AV	AV	AV	AW	AW	AW	AX	AX	AY	AZ	AZ
23	AU	AU	AV	AV	AW	AW	AW	AW	AX	AX	AY	AZ	AZ
25	AU	AV	AV	AW	AW	AW	AX	AX	AX	AY	AY	AZ	BA
29	AV	AV	AW	AW	AX	AX	AX	AX	AY	AY	AZ	BA	BA
32	AV	AW	AW	AX	AX	AX	AY	AY	AY	AZ	AZ	BA	BB
38	AW	AX	AX	AY	AY	AY	AZ	AZ	AZ	BA	BA	BB	BC
41	AX	AX	AY	AY	AY	AZ	AZ	AZ	BA	BA	BB	BC	BC

Use the table to determine the correct H position code for a D Series tandem pump.

1. Select the row corresponding to the displacement of the first pump
2. Select the column corresponding to the displacement of the rear pump.
3. Select the 2 digit code where the two displacements meet.

All available options are not shown in the model code. Please contact your Turolla OCG representative if your application requires an option not shown in the model code.

Series D Hydraulic Gear Pumps

Technical Manual

Model code / nomenclature

Order code (continued)

Single pumps



Tandem pumps



H: Tandem pump screws

For tandem pumps with R position codes 125 and D position codes N101, N104, N504, N113, or N126, please refer to Table 3 below.

Table 3

Example: H position code for a 21+19 tandem with a 125 R position code and N104 D position = AX

Use this table for the following codes: R position codes : 125 D position codes: N101, N104, N504, N113, or N126													
Displacement Code B1 position	Rear displacement of multiple pumps (reference S position code)												
	07	10	13	14	17	19	21	23	25	29	32	38	41
07	AT	AT	AU	AU	AV	AV	AV	AV	AW	AW	AX	AY	AY
10	AT	AU	AU	AV	AV	AV	AV	AW	AW	AX	AX	AY	AZ
13	AU	AU	AV	AV	AV	AW	AW	AW	AX	AX	AY	AZ	AZ
14	AU	AV	AV	AV	AW	AW	AW	AX	AX	AY	AY	AZ	AZ
17	AV	AV	AV	AW	AW	AW	AX	AX	AX	AY	AY	AZ	BA
19	AV	AV	AW	AW	AW	AX	AX	AX	AY	AY	AZ	BA	BA
21	AV	AV	AW	AW	AX	AX	AX	AY	AY	AZ	AZ	BA	BA
23	AV	AW	AW	AX	AX	AX	AY	AY	AY	AZ	AZ	BA	BB
25	AW	AW	AX	AX	AX	AY	AY	AY	AZ	AZ	BA	BB	BB
29	AW	AX	AX	AY	AY	AY	AZ	AZ	AZ	BA	BA	BB	BC
32	AX	AX	AY	AY	AY	AZ	AZ	AZ	BA	BA	BB	BC	BC
38	AY	AY	AZ	AZ	AZ	BA	BA	BA	BB	BB	BC	BD	BD
41	AY	AZ	AZ	AZ	BA	BA	BA	BB	BB	BC	BC	BD	BE

Use the table to determine the correct H position code for a D Series tandem pump.

1. Select the row corresponding to the displacement of the first pump
2. Select the column corresponding to the displacement of the rear pump.
3. Select the 2 digit code where the two displacements meet.

All available options are not shown in the model code. Please contact your Turolla OCG representative if your application requires an option not shown in the model code.

Series D Hydraulic Gear Pumps

Technical Manual

Model code / nomenclature

Order code (continued)

Single pumps



Tandem pumps



H: Tandem pump screws

For tandem pumps with R position codes 101, 104, 113, or 126 and D position codes N125, please refer to Table 4 below.

Table 4

Example: H position code for a 21+19 tandem with a 113 R position code and N125 D position = AY

Use this table for the following codes: R position codes :101, 104, 113, or 126 D position codes: N125													
Displacement Code B1 position	Rear displacement of multiple pumps (reference S position code)												
	07	10	13	14	17	19	21	23	25	29	32	38	41
07	AU	AU	AV	AV	AW	AW	AW	AW	AX	AX	AY	AZ	AZ
10	AU	AV	AV	AV	AW	AW	AW	AX	AX	AY	AY	AZ	BA
13	AV	AV	AW	AW	AW	AX	AX	AX	AY	AY	AZ	BA	BA
14	AV	AV	AW	AW	AX	AX	AX	AY	AY	AZ	AZ	BA	BA
17	AW	AW	AW	AX	AX	AX	AY	AY	AY	AZ	AZ	BA	BB
19	AW	AW	AX	AX	AX	AY	AY	AY	AZ	AZ	BA	BB	BB
21	AW	AW	AX	AX	AY	AY	AY	AY	AZ	BA	BA	BB	BB
23	AW	AX	AX	AY	AY	AY	AY	AZ	AZ	BA	BA	BB	BC
25	AX	AX	AY	AY	AY	AZ	AZ	AZ	BA	BA	BB	BC	BC
29	AX	AY	AY	AZ	AZ	AZ	BA	BA	BA	BB	BB	BC	BD
32	AY	AY	AZ	AZ	AZ	BA	BA	BA	BB	BB	BC	BD	BD
38	AZ	AZ	BA	BA	BA	BB	BB	BB	BC	BC	BD	BE	BE
41	AZ	BA	BA	BA	BB	BB	BB	BC	BC	BD	BD	BE	BF

Use the table to determine the correct H position code for a D Series tandem pump.

1. Select the row corresponding to the displacement of the first pump
2. Select the column corresponding to the displacement of the rear pump.
3. Select the 2 digit code where the two displacements meet.

All available options are not shown in the model code. Please contact your Turolla OCG representative if your application requires an option not shown in the model code.

Order code
(continued)

Single pumps



Tandem pumps



H: Tandem pump screws

For tandem pumps with R position codes 125 and D position codes N125, please refer to Table 5 below.

Table 5

Example: H position code for a 21+19 tandem with a 125 R position code and N125 D position = AZ

Use this table for the following codes: R position codes : 125 D position codes: N125													
Displacement Code B1 position	Rear displacement of multiple pumps (reference S position code)												
	07	10	13	14	17	19	21	23	25	29	32	38	41
07	AV	AW	AW	AW	AX	AX	AX	AY	AY	AZ	AZ	BA	BB
10	AW	AW	AX	AX	AX	AY	AY	AY	AZ	AZ	BA	BB	BB
13	AW	AX	AX	AX	AY	AY	AY	AZ	AZ	BA	BA	BB	BC
14	AW	AX	AX	AY	AY	AY	AZ	AZ	AZ	BA	BA	BB	BC
17	AX	AX	AY	AY	AY	AZ	AZ	AZ	BA	BA	BB	BC	BC
19	AX	AY	AY	AY	AZ	AZ	AZ	BA	BA	BB	BB	BC	BD
21	AX	AY	AY	AZ	AZ	AZ	BA	BA	BA	BB	BB	BC	BD
23	AY	AY	AZ	AZ	AZ	BA	BA	BA	BB	BB	BC	BD	BD
25	AY	AZ	AZ	AZ	BA	BA	BA	BB	BB	BC	BC	BD	BE
29	AZ	AZ	BA	BA	BA	BB	BB	BB	BC	BC	BD	BE	BE
32	AZ	BA	BA	BA	BB	BB	BB	BC	BC	BD	BD	BE	BF
38	BA	BB	BB	BB	BC	BC	BC	BD	BD	BE	BE	BF	BG
41	BB	BB	BC	BC	BC	BD	BD	BD	BE	BE	BF	BG	BG

Use the table to determine the correct H position code for a D Series tandem pump.

1. Select the row corresponding to the displacement of the first pump
2. Select the column corresponding to the displacement of the rear pump.
3. Select the 2 digit code where the two displacements meet.

All available options are not shown in the model code. Please contact your Turolia OCG representative if your application requires an option not shown in the model code.

Order code
(continued)

Single pumps



Tandem pumps



J: Nameplate

Code	Description
AN	Standard nameplate (do not use with N504)
BN	Standard label (use with rear cover code N504)

K: Special features

Code	Description
NNN	No special features, standard black paint

All available options are not shown in the model code. Please contact your Turolia OCG representative if your application requires an option not shown in the model code.

Mounting flanges

SAE-A 2-bolt

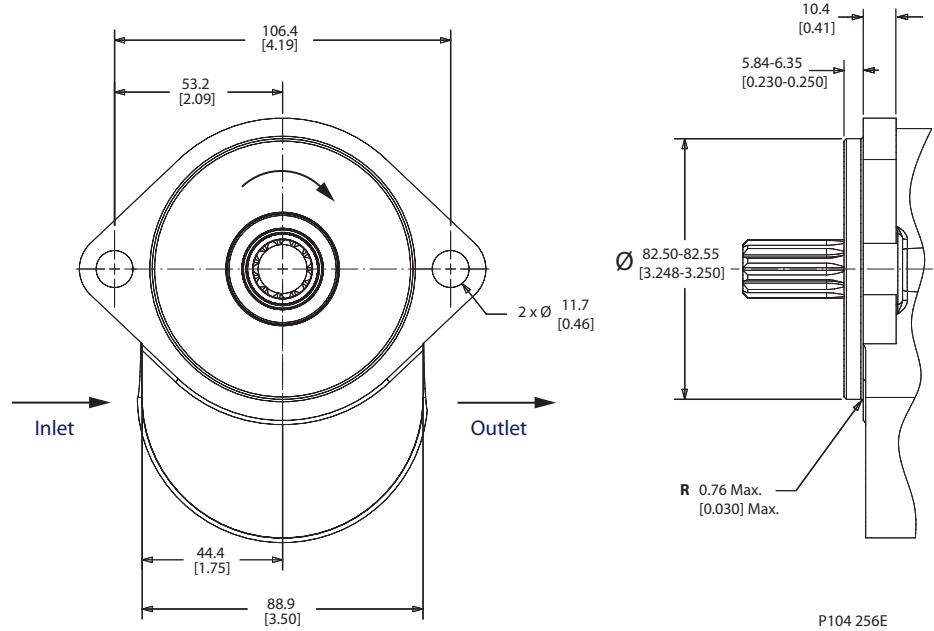

SAE-B 2-bolt

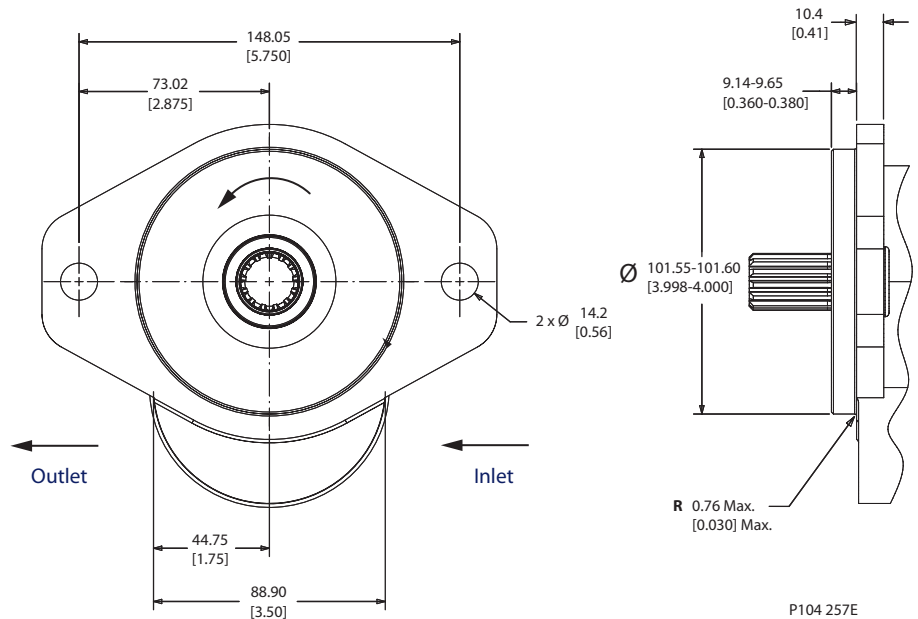

Dimensions mm [in]

**Mounting flanges
 (continued)**

Perkins® 1000 Series engine mount

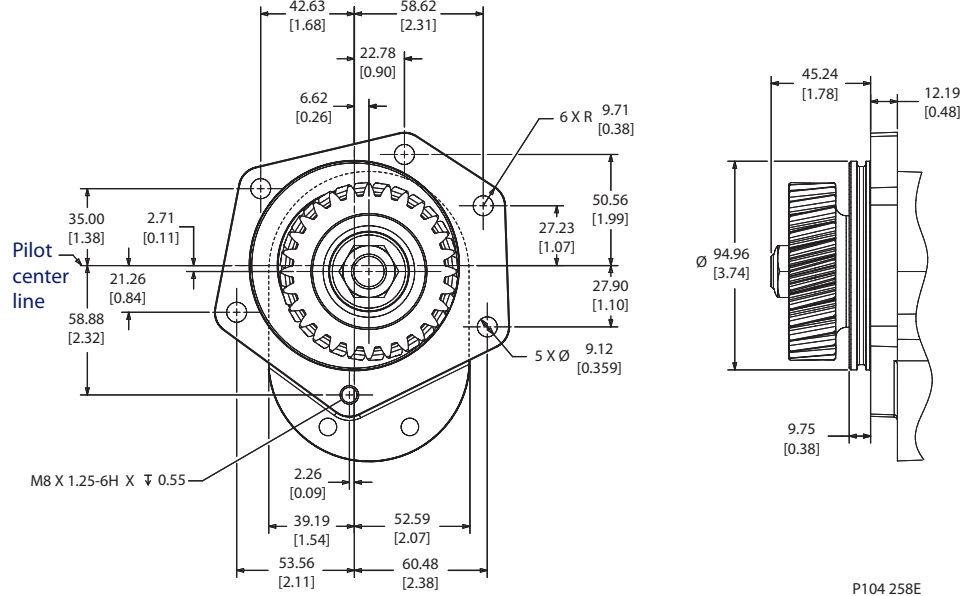

Dimensions mm [in]

Shaft options

Dimensions mm [in]

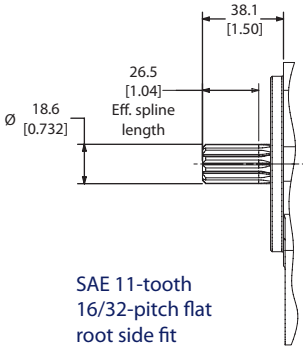
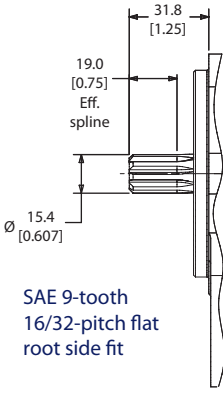
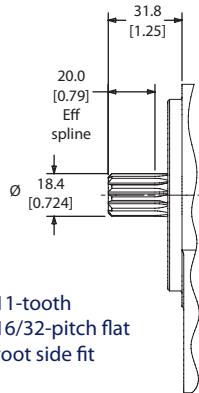
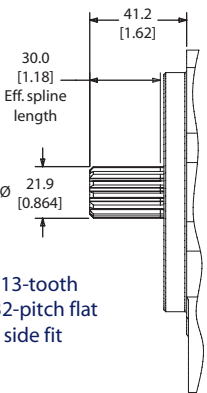
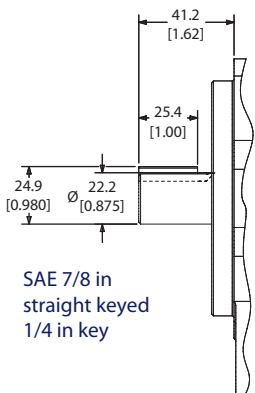
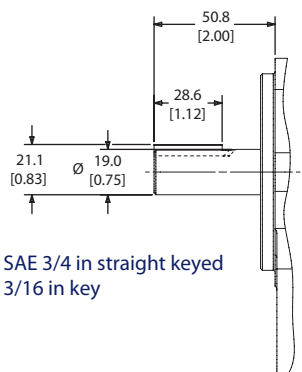
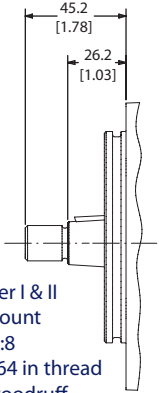
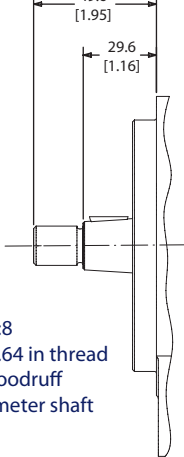
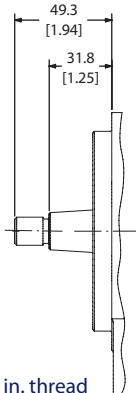
<p>Code SC</p>  <p>SAE 11-tooth 16/32-pitch flat root side fit</p> <p>P104 259E</p>	<p>Code SE</p>  <p>SAE 9-tooth 16/32-pitch flat root side fit</p> <p>P104 260E</p>	<p>Code SF</p>  <p>11-tooth 16/32-pitch flat root side fit (modified length)</p> <p>P104 261E</p>
<p>Code SH</p>  <p>SAE 13-tooth 16/32-pitch flat root side fit</p> <p>P104 262E</p>	<p>Code PB</p>  <p>SAE 7/8 in straight keyed 1/4 in key</p> <p>P104 263E</p>	<p>Code PD</p>  <p>SAE 3/4 in straight keyed 3/16 in key</p> <p>P104 264E</p>
<p>Code TS</p>  <p>Perkins Tier I & II engine mount tapered 1:8 5/8-18 x .64 in thread with #8 woodruff</p> <p>P104 265E</p>	<p>Code TG</p>  <p>Tapered 1:8 5/8-18 x 0.64 in thread with #6 woodruff 7/8 in diameter shaft</p> <p>P104 266E</p>	<p>Code TJ</p>  <p>Tapered 1:8 9/16-18 x .56 in. thread 7/8 in diameter shaft without key</p> <p>P104 267E</p>

Drive shaft torque limits

Code	Type	Diameter mm [in]	Length mm [in]	Description	Allowable shaft torque N•m [lbf•in]
SC	Spline	19.1 [0.75]	38.1 [1.50]	11 tooth, 16/32 pitch, SAE	176.3 [1560]
SE	Spline	15.9 [0.625]	38.1 [1.50]	9 tooth, 16/32 pitch, SAE-A	118.6 [1050]
SF	Spline	19.1 [0.75]	38.1 [1.50]	11 tooth, 16/32 pitch, modified length	176.3 [1560]
SH	Spline	22.2 [0.875]	41.2 [1.62]	13 tooth, 16/32 pitch, SAE-B	248.6 [2200]
PB	Straight key	22.2 [0.875]	41.2 [1.62]	7/8 inch diameter straight key, SAE-B, includes 1/4 inch key	248.6 [2200]
PD	Straight key	22.2 [0.875]	50.8 [2.00]	3/4 inch diameter straight key, SAE, includes 3/16 inch key	158.2 [1400]
TS	Tapered	22.2 [0.875]	45.2 [1.78]	Perkins® 1:8 taper, with number 8 key	225.9 [2000]
TG	Tapered	22.2 [0.875]	49.6 [1.95]	Tapered 1:8 with number 6 woodruff key, 7/8 inch diameter, 5/8-18 x 0.64 inch thread	225.9 [2000]
TJ	Tapered	22.2 [0.875]	49.3 [1.94]	Tapered 1:8 without key, 7/8 inch diameter, 9/16-18 x 0.56 inch thread	225.9 [2000]
—	—	—	—	Multiple pump connecting shaft	143.8 [1273]

Limit operating pressures when applying multiple section pumps. This ensures the maximum simultaneous input torque through the drive shaft and connecting shafts. Do not exceed the *Allowable Shaft Torque Limits* as shown in the table above.

Port options

SAE O-ring

Code	Inlet port	Outlet port
N101	1 1/16 in - 12, side	7/8 in - 14, side
N104	1 5/16 in - 12, side	1 1/16 in - 12, side
N504	1 5/16 in - 12, rear	1 1/16 in - 12, rear
N113	None (single inlet)	7/8 in - 14 SAE, side
N125	1 5/8 in - 12, SAE, side	1 1/16 in - 12, SAE, side
N126	None (single inlet)	1 1/16 in - 12, side

Side

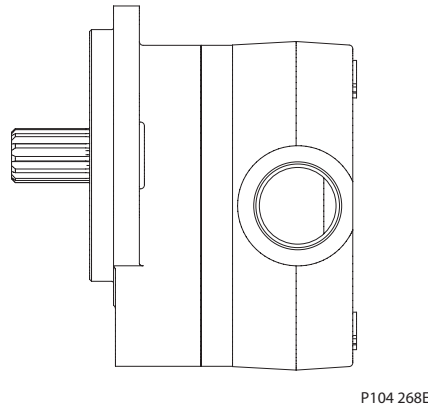

Rear (CW rotation shown)

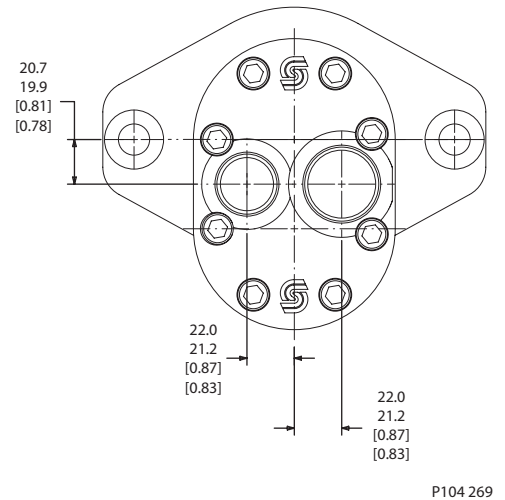

Code N125 (1-5/8 in O-ring inlet), CW rotation

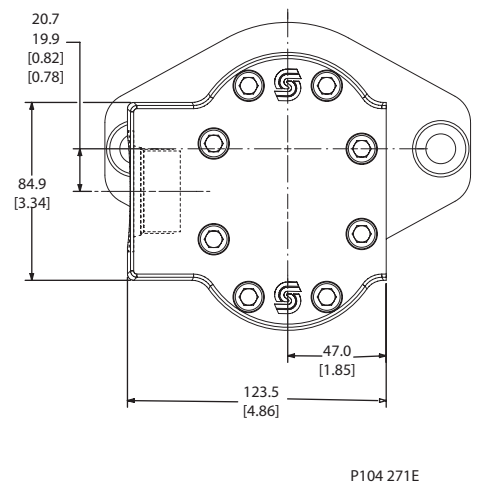
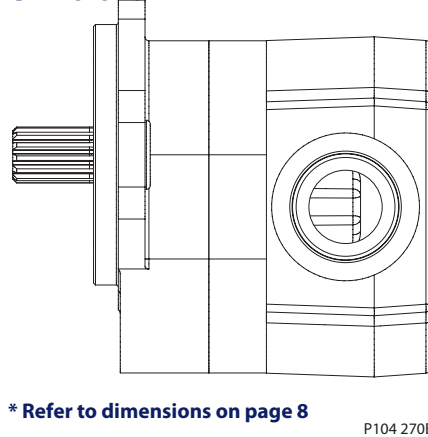

* Refer to dimensions on page 8

Dimensions mm [in]

Valve options

Fixed priority flow valve

D series pumps are available with an optional fixed orifice Priority Flow Divider (PFD) valve integrated into the rear cover. The PFD valve divides the flow and provides a fixed amount of flow to the Controlled Flow (CF) port for priority functions such as steering. The remaining flow is routed to the Excess Flow (EF) port for additional functions such as directional control valves and fan drives.

- Priority flow is pressure compensated, therefore priority flow is independent of excess flow working pressures.
- The priority flow is factory set and can deliver 7.6 to 34.1 l/min (2 to 9 US gal/min).
- The priority circuit has an integral, direct acting pilot relief valve with internal drain.
- Settings range from 34 to 172 bar (500 to 2500 psi).
- The D series PFD can be used in tandems and other multiple pump configurations, but only in the rear pumping section.
- Rear and side porting options are available.

Ports

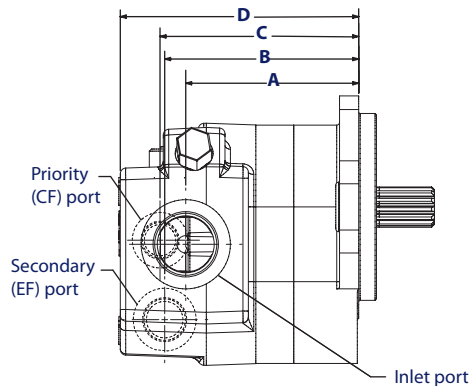
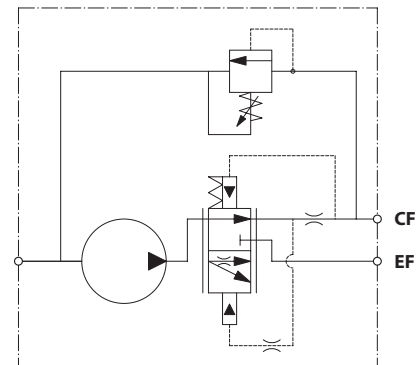

Illustration of right-hand (CW) rotation
Refer to dimensions on page 8

P104 274E

Fixed priority flow divider pump



P106 105E

Priority flow divider pump dimensions

Description	Code	07	10	13	14	17	19	21	23	25	29	32	36	38	41	45
Displacement	cm ³ /rev	7.0	9.5	12.6	14.3	17.0	19.0	20.5	22.5	25.4	29.0	31.8	36.0	38.0	41.0	45.1
	in ³ /rev	0.43	0.58	0.77	0.87	1.04	1.16	1.25	1.37	1.55	1.77	1.94	2.20	2.32	2.50	2.75
Weight	kg	8.8	9.0	9.2	9.3	9.4	9.6	9.6	9.8	9.9	10.1	10.3	10.6	10.7	10.7	11.0
	lb	19.5	19.8	20.2	20.4	20.8	21.1	21.2	21.5	21.9	22.3	22.7	23.3	23.5	23.9	24.4
Dimension A1 Inlet port distance sizes up to 1-5/16 in SAE	mm	80.5	82.9	86.1	88.3	90.4	92.5	94.0	95.8	98.8	102.4	105.2	109.4	111.4	114.4	118.6
	in	3.17	3.27	3.39	3.48	3.56	3.64	3.70	3.77	3.89	4.03	4.14	4.31	4.39	4.50	4.67
Dimension A2 Inlet port distance 1-5/8 in SAE	mm	90.2	92.6	95.8	97.9	100.1	102.1	103.6	105.5	108.5	112.0	114.8	119.1	121.1	124.1	128.3
	in	3.55	3.65	3.77	3.86	3.94	4.02	4.08	4.15	4.27	4.41	4.52	4.69	4.77	4.88	5.05
Dimension B Secondary port distance	mm	91.9	94.4	97.5	99.7	101.9	103.9	105.4	107.3	110.2	113.8	116.6	120.9	122.8	125.8	130.0
	in	3.62	3.72	3.84	3.93	4.01	4.09	4.15	4.22	4.34	4.48	4.59	4.76	4.84	4.95	5.12
Dimension C priority port distance	mm	94.5	96.9	100.1	102.2	104.4	106.4	108.0	109.8	112.8	116.4	119.1	123.4	125.4	128.4	132.6
	in	3.72	3.82	3.94	4.03	4.11	4.19	4.25	4.32	4.44	4.58	4.69	4.86	4.94	5.05	5.22
Dimension D overall length	mm	116.1	118.5	121.7	123.8	126.0	128.0	129.5	131.4	134.4	137.9	140.7	145.0	147.0	150.0	154.2
	in	4.57	4.67	4.79	4.88	4.96	5.04	5.10	5.17	5.29	5.43	5.54	5.71	5.79	5.90	6.07

Valve options
(continued)

Pumps with priority flow dividers

Side port locations (CW rotation shown)

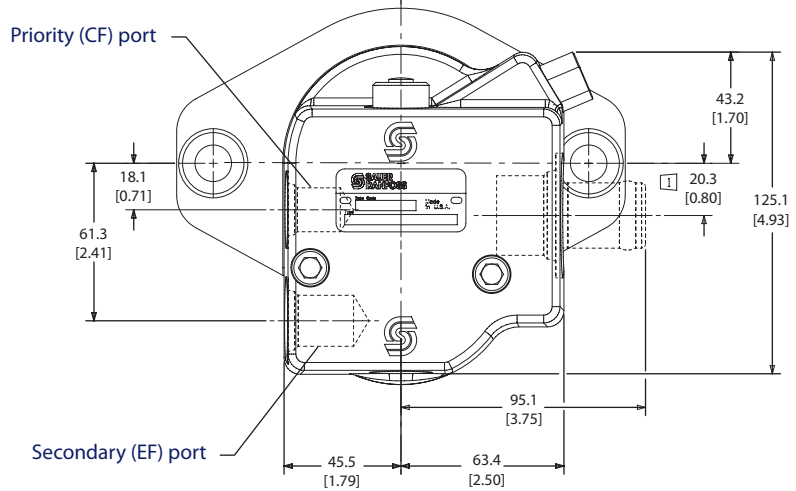

P104 276E

Rear port locations (CW rotation)

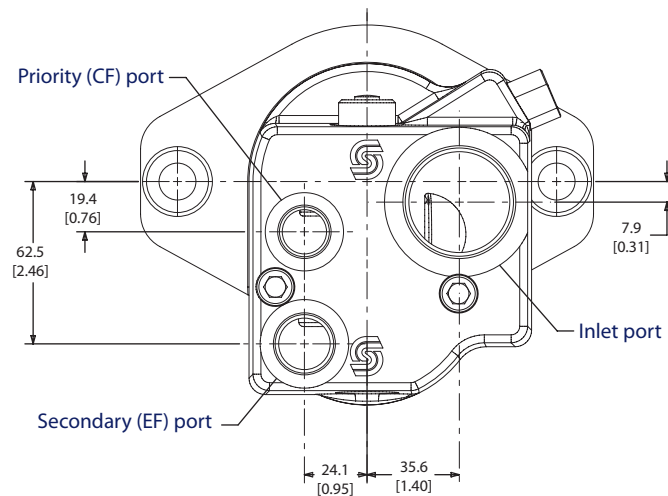

P104 277E

PFD port options

Contact your Turolla OCG representative for information concerning PFD port options.

Dimensions mm [in]

Valve options

Load sense priority flow valve

D series pumps are available with an optional Load Sense (LS) priority valve integrated into the rear cover. The LS priority valve supplies priority flow on demand to functions such as load sense steering, while the Excess Flow (EF) is available for secondary functions such as directional control valves and fan drives. A load sense signal line from the priority circuit to the gear pump's LS port governs flow to the primary circuit. As the load sense signal pressure increases, priority (CF) flow also increases. When the controlled function is idle (no load sense demand), full pump flow is available for the secondary functions.

- The D series LS priority valve is available with 40 l/min [10 US gal/min] and 80 l/min [21 US gal/min] flow settings.
- The priority circuit is available with an optional integral direct acting pilot relief valve with internal drain. Pressure settings range from 34 to 172 bar [500 to 2500 psi].
- The load sense valve is dynamic and has a constant flow of 0.5 to 1.0 l/min [0.13 to 0.26 US gal/min] present at all times to ensure fast reaction.
- The D series PFD can be used in tandems and other multiple pump configurations, but only in the rear pumping section.
- Rear and side porting options are available.

Side port

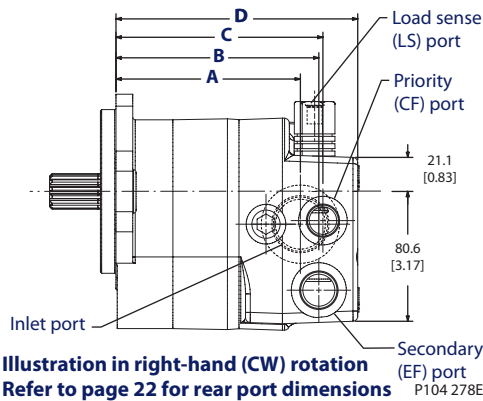

LS pump

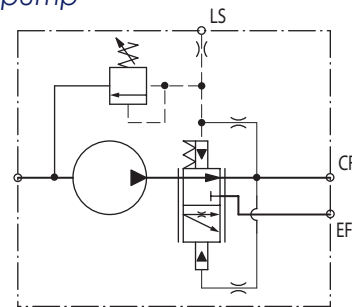

Load sense pump dimensions

P104 279

Description	Code	07	10	13	14	17	19	21	23	25	29	32	36	38	41	45
Displacement	cm ³ /rev	7.0	9.5	12.6	14.3	17.0	19.0	20.5	22.5	25.4	29.0	31.8	36.0	38.0	41.0	45.1
	in ³ /rev	0.43	0.58	0.77	0.87	1.04	1.16	1.25	1.37	1.55	1.77	1.94	2.20	2.32	2.50	2.75
Weight	kg	8.8	9.0	9.2	9.3	9.4	9.6	9.6	9.8	9.9	10.1	10.3	10.6	10.7	10.7	11.0
	lb	19.5	19.8	20.2	20.4	20.8	21.1	21.2	21.5	21.9	22.3	22.7	23.3	23.5	23.9	24.4
Dimension A1 Inlet port distance port sizes up to 1-5/16 in SAE	mm	80.5	82.9	86.1	88.3	90.4	92.5	94.0	95.8	98.8	102.4	105.2	109.4	111.4	114.4	118.6
	in	3.17	3.27	3.39	3.48	3.56	3.64	3.70	3.77	3.89	4.03	4.14	4.31	4.39	4.50	4.67
Dimension A2 Inlet port distance 1-5/8 in SAE	mm	90.2	92.6	95.8	97.9	100.1	102.1	103.6	105.5	108.5	112.0	114.8	119.1	121.1	124.1	128.3
	in	3.55	3.65	3.77	3.86	3.94	4.02	4.08	4.15	4.27	4.41	4.52	4.69	4.77	4.88	5.05
Dimension B Secondary port distance	mm	91.9	94.4	97.5	99.7	101.9	103.9	105.4	107.3	110.2	113.8	116.6	120.9	122.8	125.8	130.0
	in	3.62	3.72	3.84	3.93	4.01	4.09	4.15	4.22	4.34	4.48	4.59	4.76	4.84	4.95	5.12
Dimension C Priority port distance	mm	94.5	96.9	100.1	102.2	104.4	106.4	108.0	109.8	112.8	116.4	119.1	123.4	125.4	128.4	132.6
	in	3.72	3.82	3.94	4.03	4.11	4.19	4.25	4.32	4.44	4.58	4.69	4.86	4.94	5.05	5.22
Dimension D Overall length	mm	116.1	118.5	121.7	123.8	126.0	128.0	129.5	131.4	134.4	137.9	140.7	145.0	147.0	150.0	154.2
	in	4.57	4.67	4.79	4.88	4.96	5.04	5.10	5.17	5.29	5.43	5.54	5.71	5.79	5.90	6.07

Valve options
(continued)

Pumps with load sense priority flow valves

Side port locations (CW rotation)

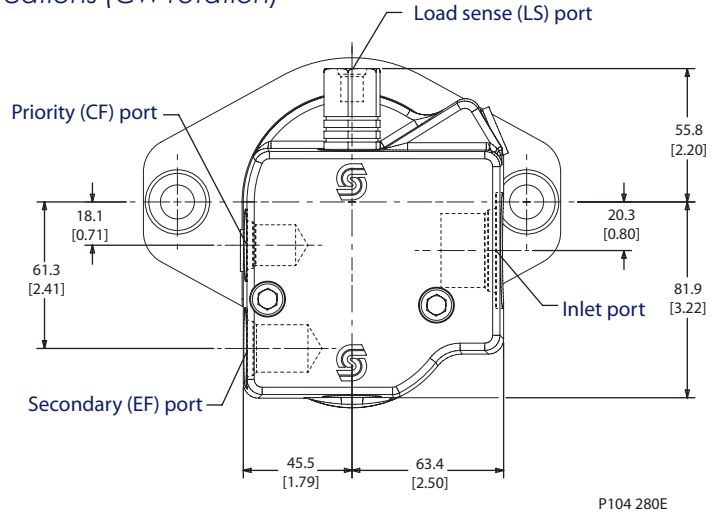

Rear port locations (CCW rotation shown)

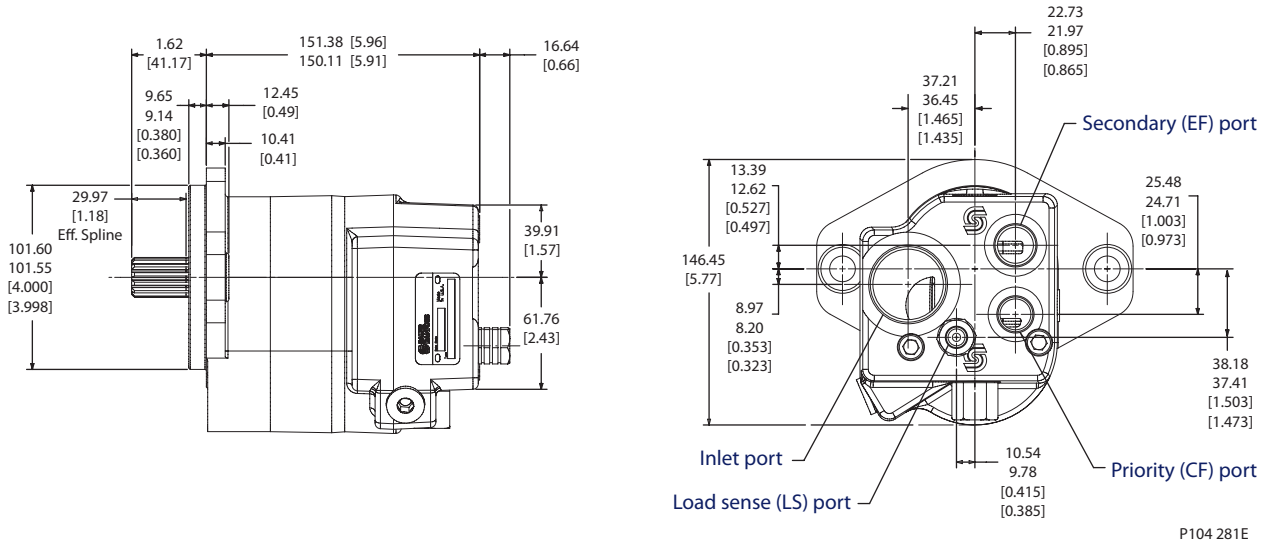

Load sense port options

Contact your Turolia OCG representative for information concerning load sense port options.

Dimensions mm [in]

Flow performance

The graphs on this, and the following pages, show output flow for the D series single pumps at various working pressures as a function of speed. Data were taken using hydraulic fluid conforming to ISO VG46 at 50°C (120° F) with viscosity at 28 mm²/sec (cSt) [132 SUS].

Model 07D (l/min)

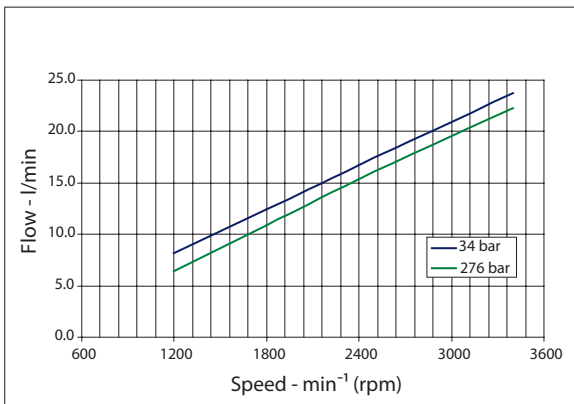

Model 07D (US gal/min)

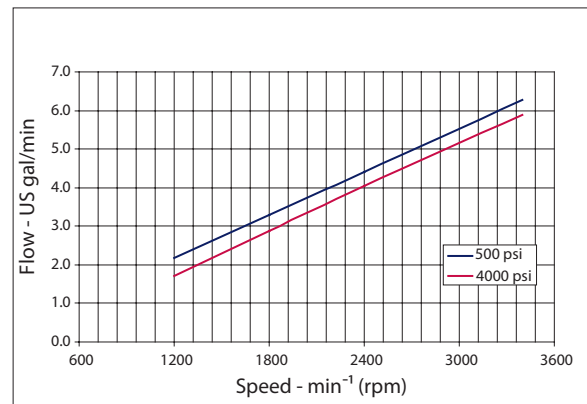

Model 10D (l/min)

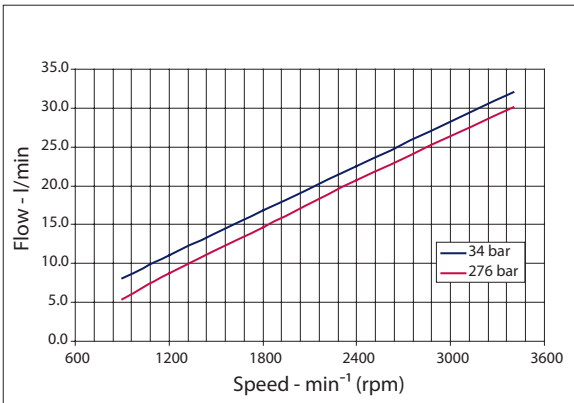

Model 10D (US gal/min)

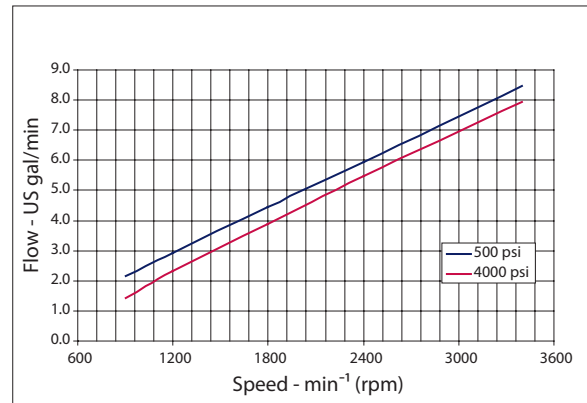

Model 13D (l/min)

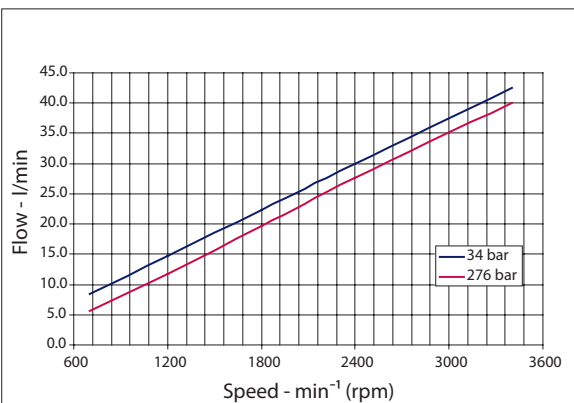

Model 13D (US gal/min)

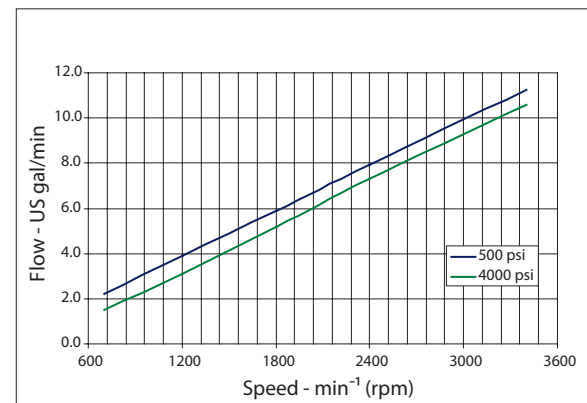

Flow performance (continued)

Model 14D (l/min)

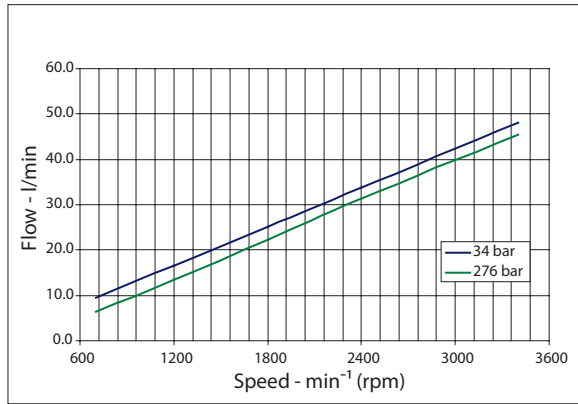

Model 14D (US gal/min)

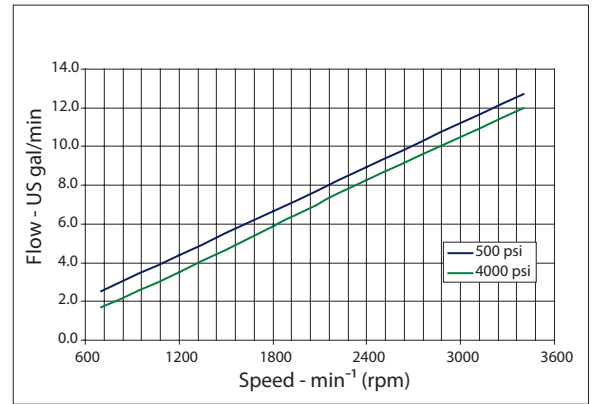

Model 17D (l/min)

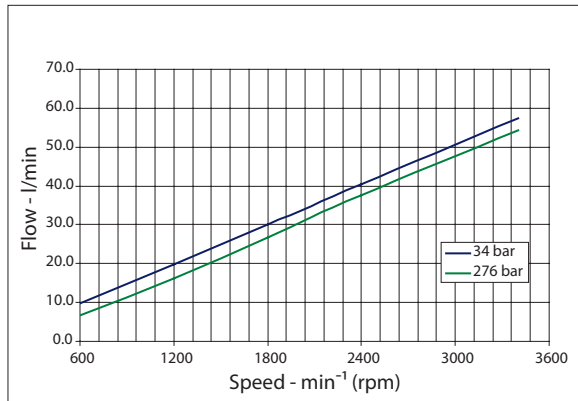

Model 17D (US gal/min)

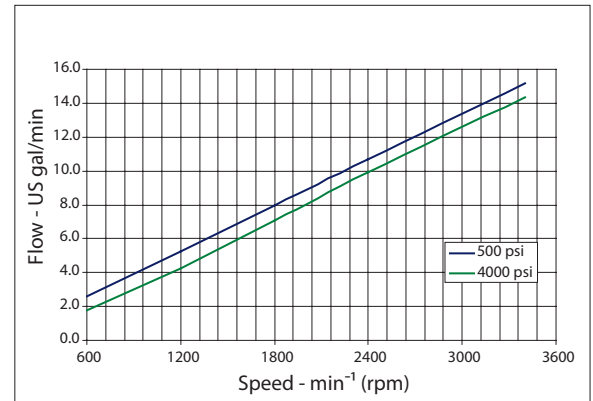

Model 19D (l/min)

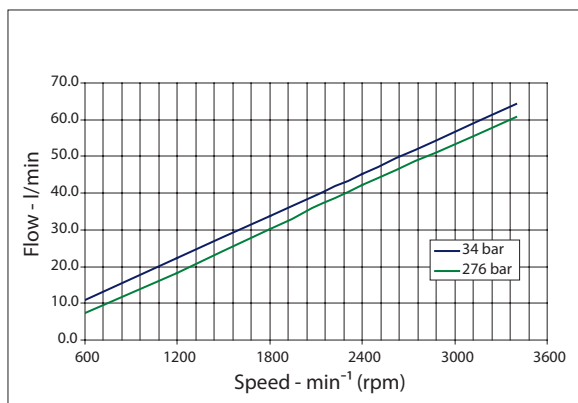

Model 19D (US gal/min)

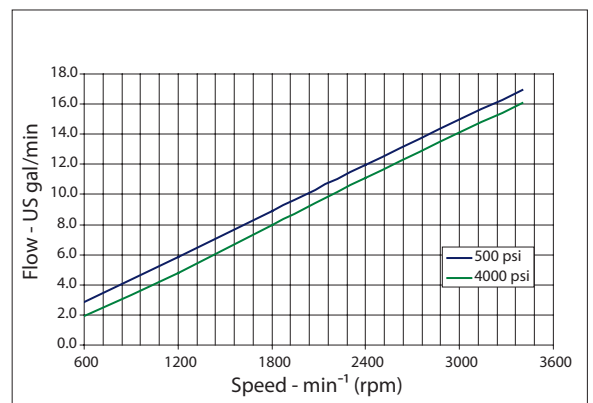

Flow performance (continued)

Model 21D (l/min)

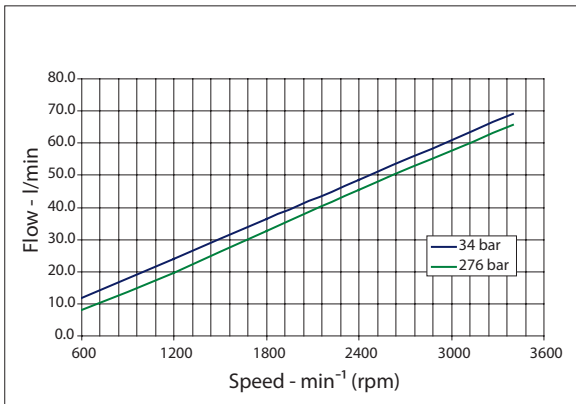

Model 21D (US gal/min)

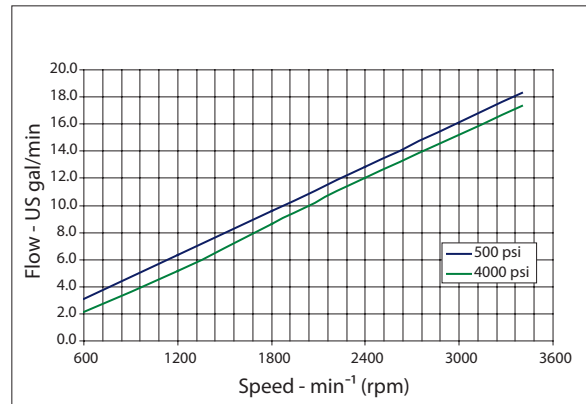

Model 23D (l/min)

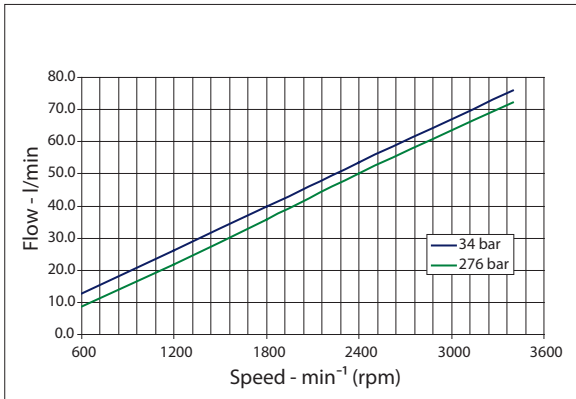

Model 23D (US gal/min)

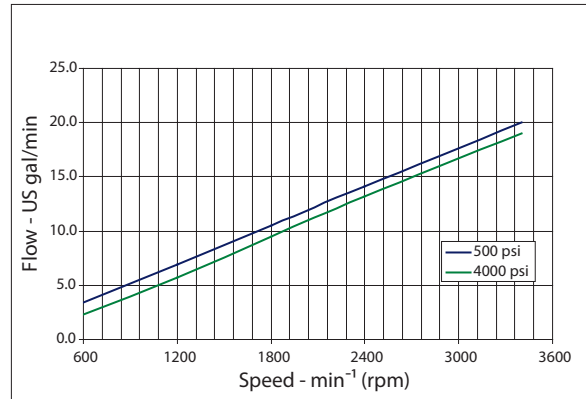

Model 25D (l/min)

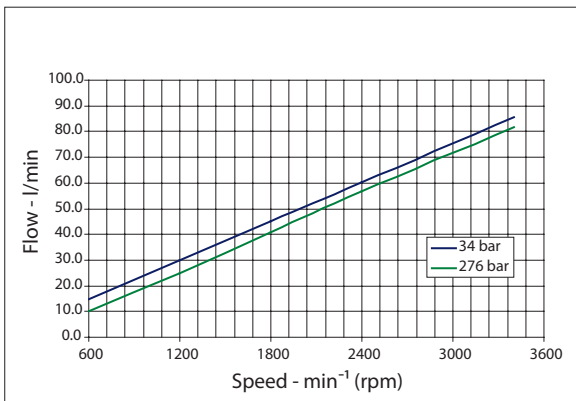

Model 25D (US gal/min)

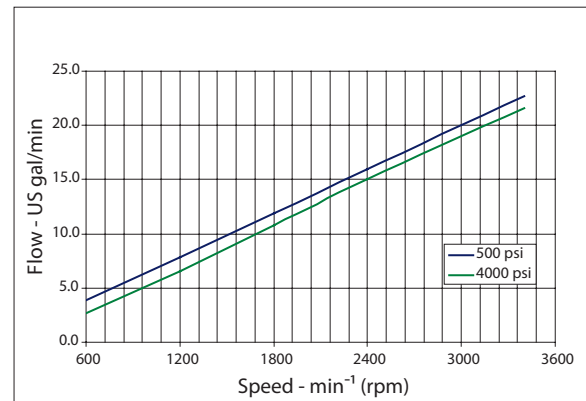

Flow performance (continued)

Model 29D (l/min)

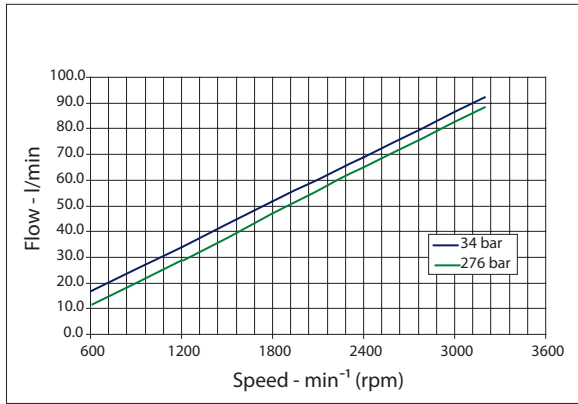

Model 29D (US gal/min)

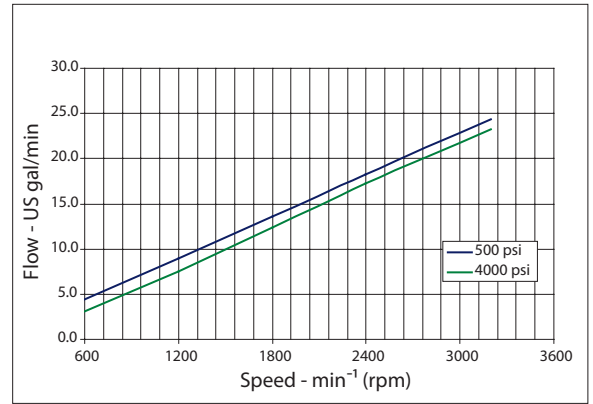

Model 32D (l/min)

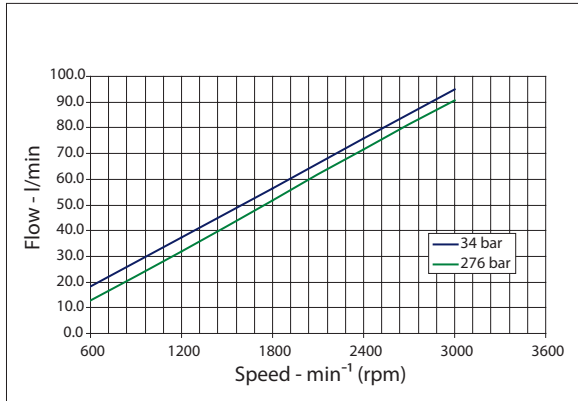

Model 32D (US gal/min)

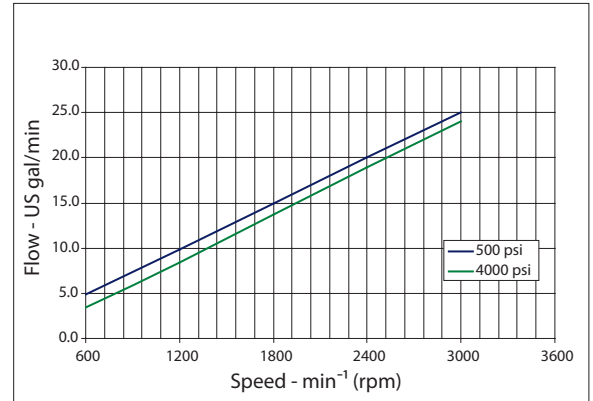

Model 38D (l/min)

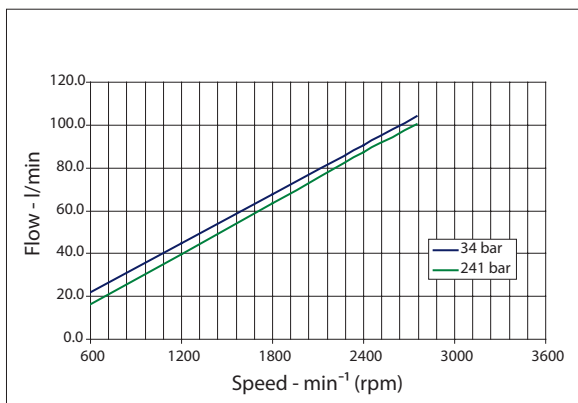

Model 38D (US gal/min)

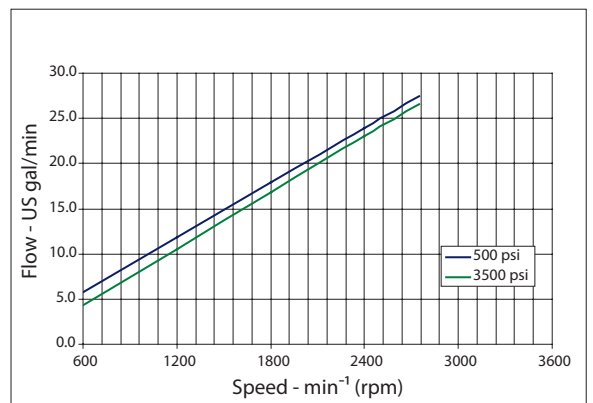

Flow performance (continued)

Model 41D (l/min)

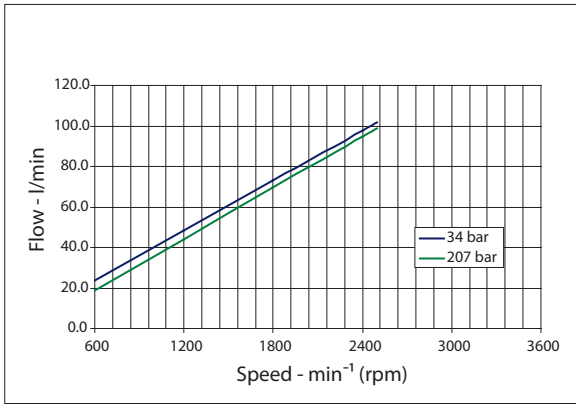

Model 41D (US gal/min)

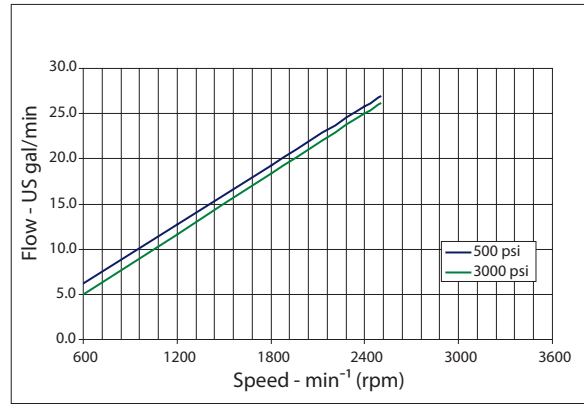

Model 45D (l/min)

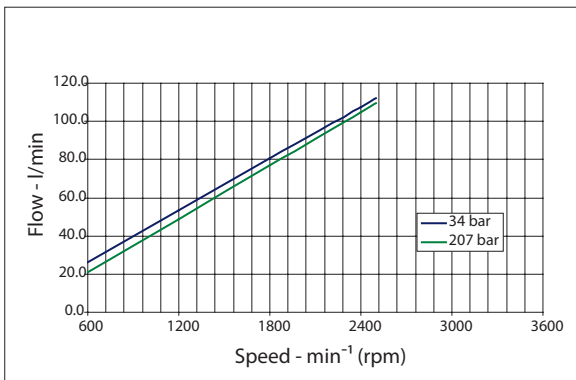

Model 45D (US gal/min)

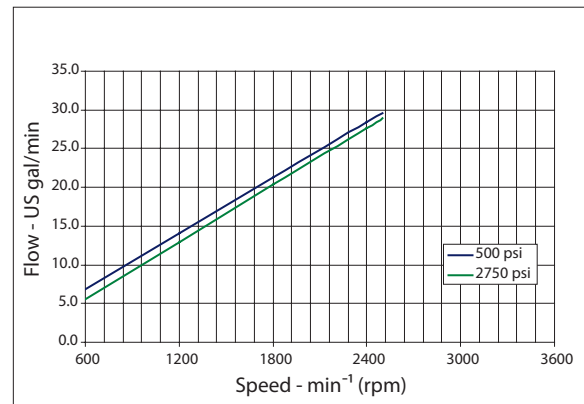

Operating parameters

Definitions of the D Series operating parameters appear below. Consult Turolla OCG technical support for applications running outside of these parameters.

Line sizing

Inlet conditions should be reviewed to minimize inlet oil velocity and inlet vacuums. This will result in quieter system operation, reduced operating temperatures and longer pump life. To avoid pump cavitation, the maximum inlet line flow should not exceed 4.3 m/sec (14 ft/sec). Discharge velocity should be limited to 8 m/sec (18 ft/sec).

Recommended fluid velocities

Inlet	4.3 m/sec [14 ft/sec]
Discharge	8.0 m/sec [18 ft/sec]

Inlet pressure

Continuous inlet vacuum should not exceed 0.8 bar absolute (6.3 in Hg). During cold starts, a vacuum of 0.6 bar absolute (12.2 in Hg) can be tolerated for short durations.

Inlet pressure

Recommended minimum	0.8 bar absolute 6.3 in Hg vac
Minimum at cold start	0.6 bar absolute 12.2 in Hg vac

Rated pressure

D series pumps are designed to operate continuously at rated pressure. Operating at or below this pressure will yield satisfactory product life.

Peak pressure

Peak pressure is the highest (intermittent) pressure allowed and is determined by the relief valve reaction overshoot. Peak pressure is assumed to occur for less than 100 ms in duration.

Pressure vs. time

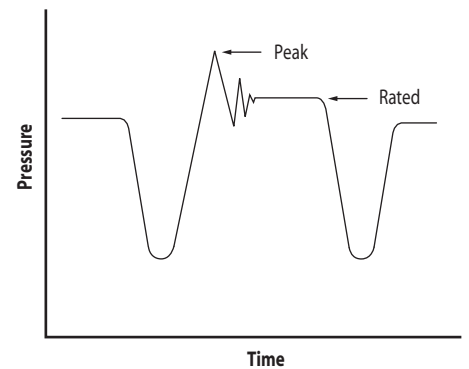

Maximum speed ratings

The maximum speed is the highest recommended operating speed. Maximum speed ratings assume operation within recommended inlet pressures and use of quality ISO VG46 hydraulic fluid. Operating at or below this speed will yield satisfactory product life.

Minimum speed ratings

Minimum speed is the lower limit of operation and is a function of discharge pressure and fluid temperature.

**Operating parameters
(continued)**

Fluids

Catalog ratings for D series gear pumps are based on operation with a premium hydraulic fluid containing oxidation, rust, and foam inhibitors. The fluid must possess good thermal and hydrolytic stability to prevent wear, erosion, and corrosion of internal components. Consult Turolla OCG technical support before using non-petroleum based (including water glycol), fire-resistant, or biodegradable fluids. The use of these fluids may require special seal materials and/or specially designed hardware.

For more information on hydraulic fluid selection, see Turolla OCG publications **520L0463** *Hydraulic Fluids and Lubricants, Technical Information*, and **520L465** *Experience with Biodegradable Hydraulic Fluids, Technical Information*.

Temperature

Temperature and viscosity requirements must be concurrently satisfied. The pump should be run at or below the maximum continuous temperature.

The peak temperature is based upon material properties and should never be exceeded. Cold oil will generally not affect the durability of the pump, but it may affect the ability to flow oil and transmit power. Ideally, the lowest expected oil temperature should remain at least 16C (30F) above the pour point of the fluid.

Temperature limits

Minimum, cold start	-30 °C [-20 °F]
Maximum continuous	82 °C [180 °F]
Peak (intermittent)	104 °C [220 °F]

Viscosity

Minimum viscosity should be encountered only during brief occasions of maximum ambient temperature and severe duty cycle operation.

Fluid viscosity

limits mm²/sec (cSt) [SUS]

Minimum, intermittent	10 [60]
Recommended range	12 to 60 [66 to 290]
Maximum, cold start	1600 [7500]

The maximum viscosity should be encountered only during cold start. Limit the operating speed until the fluid warms up.

Operating parameters (continued)

Filtration

To prevent damage to the pump, including premature wear, fluid entering the pump inlet must be free of contaminants. D series pumps require system filtration capable of maintaining fluid cleanliness at ISO 4406-1999 class 22/18/13 or better.

Turolla OCG does not recommend suction line filtration. Suction line filtration can cause high inlet vacuum, which limits pump operating speed. Instead we recommend a 100 micron screen in the reservoir covering the pump inlet. This protects the pump from coarse particle ingestion.

Return line filtration is the preferred method for open circuit systems. Consider these factors when selecting a system filter:

- Cleanliness specifications
- Contaminant ingress rates
- Flow capacity
- Desired maintenance interval

Typically, a filter with a beta ratio of $\beta_{10} = 10$ is adequate. However, because each system is unique, only a thorough testing and evaluation program can fully validate the filtration system. For more information, see Turolla OCG publication **520L0467**, *Design Guidelines for Hydraulic Fluid Cleanliness*.

Reservoir

The reservoir provides clean fluid, dissipates heat, and removes entrained air from the hydraulic fluid. It allows for fluid volume changes associated with fluid expansion and cylinder differential volumes. Minimum reservoir capacity depends on the volume needed to perform these functions. Typically, a capacity of one to three times the pump flow (per minute) is satisfactory. Locate the reservoir outlet (suction line) near the bottom, allowing clearance for settling foreign particles. Place the reservoir inlet (return lines) below the lowest expected fluid level, as far away from the outlet as possible.

Pump drives

Pump drive

D Series pumps can be direct-driven by tapered, straight keyed or splined drive. They are well suited for external gear or pulley drive. Gear drive for the pump can be by spur or helical gear.

Contact Turolla OCG technical support for all non-standard direct-driven and all gear-driven or pulley-driven applications. The figures on the next page show the information Turolla OCG requires to analyze applications using a gear or pulley drive. From this information, Turolla OCG determines:

- If the drive method is feasible
- Optimum range of angles for driving the pump or motor
- Pressure limitations, if any, for applications where the drive angle is customer specified
- Helical gear thrust load and its effect on the pump

Use a spring-loaded belt tensioner in belt drive designs.

Plug-in drives

Plug-in drives are acceptable only with a splined shaft. Plug-in drives are acceptable if the concentricity between the mating spline and pilot diameter is within 0.1 mm [.004 in.] If a plug-in drive is used, lubricate the spline drive with flowing oil. Use an intermediate coupling to minimize radial or thrust shaft loads.

Have Turolla OCG technical support review any known thrust or radial loads on the pump drive shaft. We need to know if the load is stationary or rotates with the shaft (typical of an imbalanced load). Radial external load-handling capability is excellent in D Series pumps, but it should be minimized.

In applications where you can't avoid external shaft loads, optimize the orientation and magnitude of the load on the pump to minimize the impact. Don't use splined shafts for belt or gear drive applications. Use a tapered input shaft for all gear and pulley drives.

**Pump drives
(continued)**

Pulley drive

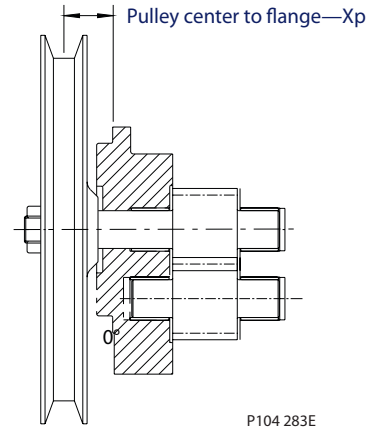
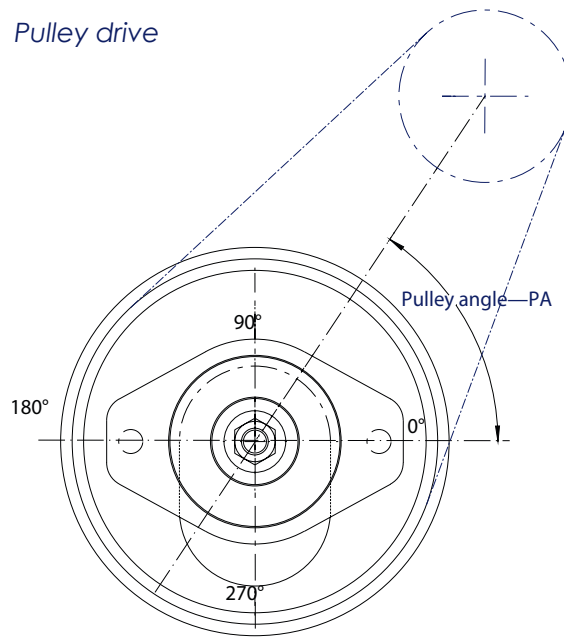

P104 283E

Pulley drive parameters

Direction of pump rotation	LH or RH
Pulley pitch diameter (PD)	inch or mm
Belt tension	lb or kg
Distance from flange	inch or mm
Pulley angle (PA)	degrees

Gear drive

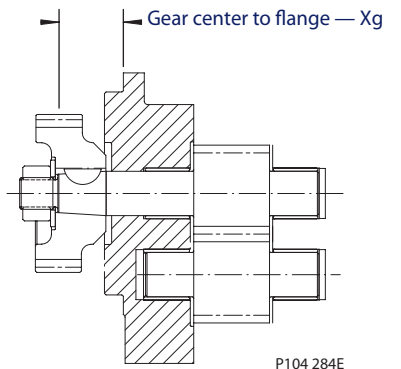
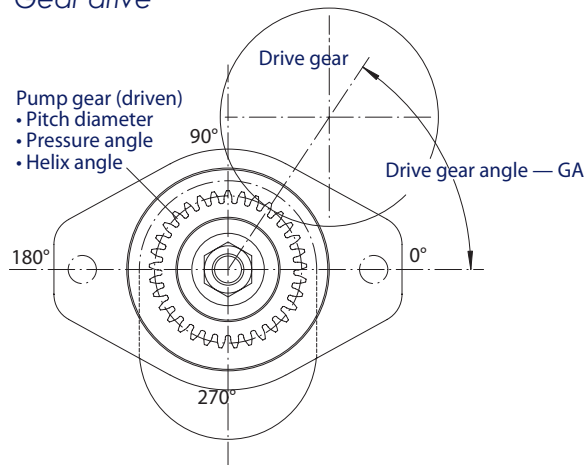

P104 284E

Gear drive parameters

Direction of pump rotation	LH or RH
Gear pitch diameter (PD)	inch or mm
Pressure angle (Pag)	degrees
Pressure angle specified	normal or traverse
Helix angle	degrees
Hand of helix	LH or RH
Distance from flange (Xg)	inch or mm
Gear angle (GA)	degrees

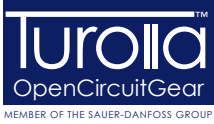

Our Products

Aluminum Gear Pumps

Aluminum Gear Motors

Cast Iron Gear Pumps

Cast Iron Gear Motors

Fan Drive Gear Motors Aluminum

Fan Drive Gear Motors Cast Iron

Turolla OpenCircuitGear™

Turolla OCG, with more than 60 years of experience in designing and manufacturing gear pumps, gear motors and fan drive motors of superior quality, is the ideal partner ensuring robustness and reliability to your work functions.

We are fast and responsive - the first to specify a customer product, the most experienced in providing technical knowledge and support for fan drive solutions.

We offer a lean value chain to our partners and customers and the shortest lead time in the market.

Turolla OCG is member of the Sauer-Danfoss Group.

Local address:

Turolla OpenCircuitGear

Via Villanova 28
40050 Villanova di Castenaso
Bologna, Italy
Phone: +39 051 6054411
Fax: +39 051 6053033

Turolla OpenCircuitGear

Kukučínova 2148-84
01701 Považská Bystrica, Slovakia
Phone: +421 424 301 544
Fax: +421 424 301 626

Turolla OpenCircuitGear

2800 East 13th Street
Ames, IA 50010
USA
Phone: +1 515 239 6000
Fax: +1 515 239 6618