

# HC6 miniBOOSTER



**HC6 versions:** 9 different intensification factors

**P<sub>IN</sub>:** 20 – 207 bar (inlet pressure)

**P<sub>H</sub>:** 800 bar maximum (outlet pressure)

**P<sub>RETURN</sub>:** As low as possible (return pressure to tank)

**P<sub>OUTLET</sub>:**  $P_H = (P_{IN} - P_{RETURN}) \cdot i$  (intensification)

**Mounting:** Inline tube

**Accessories:** Pilot- operated dump valve available

**A model** = no dump valve

**B model** = with dump valve

**G model** = direct proportionally controlled

## Description

The HC6 is a high- flow unit which is capable of delivering up to 13 l/ min flow on the high- pressure end. Like other miniBOOSTER models, the HC6 raises supplied pressure to a higher outlet pressure and automatically compensates for consumption of oil to maintain the high pressure. Adjustment of the outlet pressure is carried out by varying the supplied pressure. Relative to its flow capability, the HC6 is a compact unit weighing only 9.5 kg.

## Flow rates

Intensification factor <i>i</i>	Max. outlet flow l/ min	Max. inlet flow l/ min
1.3	3.1	50.0
1.5	2.5	50.0
1.9	2.0	50.0
2.5	13.0	70.0
3.3	11.0	70.0
4.0	9.0	70.0
4.9	7.0	70.0
6.3	5.5	70.0
8.2	4.5	70.0

## Dimensions

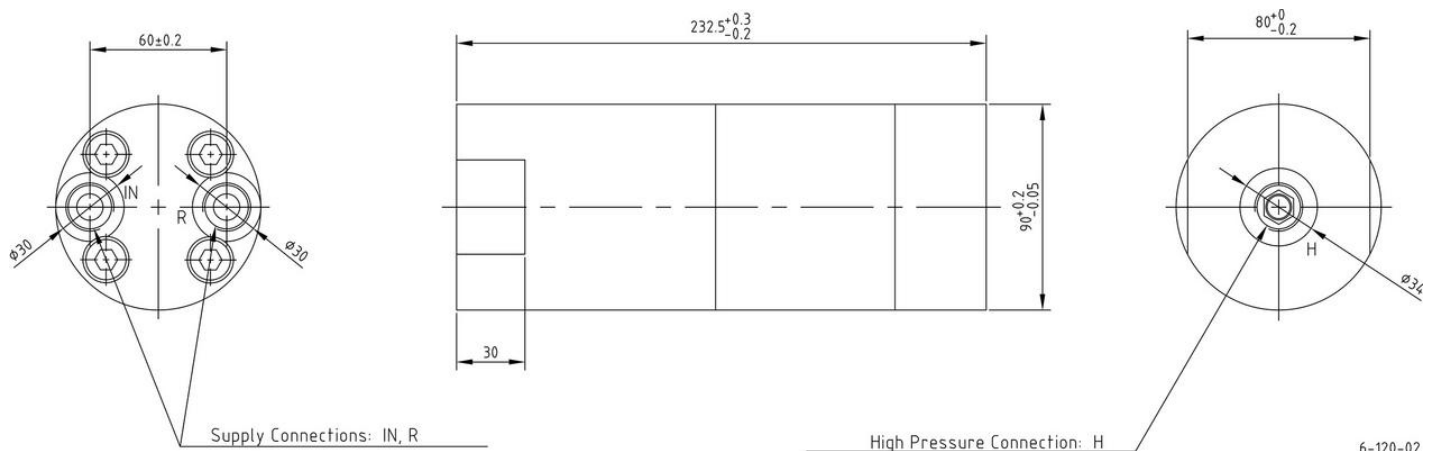

## Functions

The basic operation is illustrated in the function diagram. Oil is fed through the directional valve CV to the IN port, flowing freely through the check valves KV1, KV2 and DV to the high- pressure side H. In this condition maximum flow through the booster is achieved giving a fast-forward function.

When pump pressure is reached on the high- pressure side H, valves KV1, KV2 and DV will close. The end pressure will be achieved by the oscillating pump unit OP. The unit will automatically stall when end pressure on the high- pressure side H is reached. If a pressure drop on the high- pressure side exists due to consumption or leakage, the OP valve will automatically operate to maintain the end pressure.

## Function Diagram

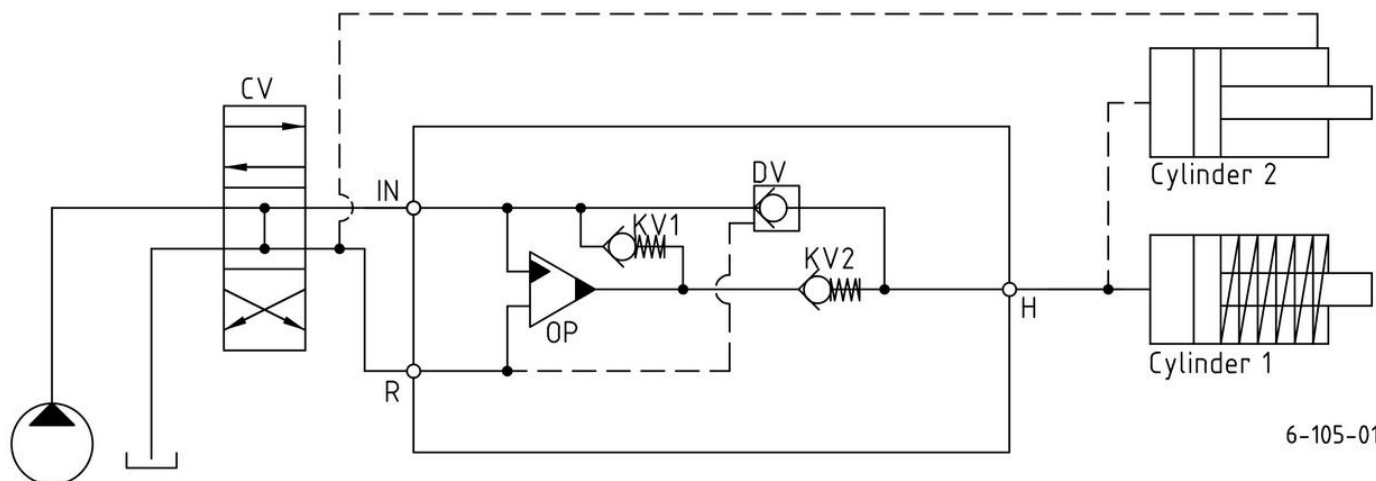

## Connection types

Connection	IN / R	H
1	1/2" BSPP	1/2" BSPP
2	3/4-16" UNF	3/4-16" UNF

## Max. tightening torque BSPP

	IN / R	H
	1/2" BSPP	1/2" BSPP
with steel washer	13.0 da Nm	13.0 da Nm
with aluminium washer	7.0 da Nm	–
with cutting edge	13.0 da Nm	13.0 da Nm

## Max. tightening torque UNF

	IN / R	H
	3/4-16" UNF	3/4-16" UNF
with o- ring	3.5 da/ Nm	6.0 da/ Nm

## Fluids and materials

Please see: General specifications

## Ordering an HC6

Ordering example of an HC6 with  $i = 4.0$ , DV incorporated and BSPP connections: HC6 - 4.0 - B - 1

<b>Model</b>	<b>Intensification, <math>i</math></b>	<b>Dump valve</b>	<b>Connections</b>
HC6	your selection...	your selection...	your selection...
	see flow rate table	A = (no) / A model	1
		B = (yes) / B model	2
		G = (proportional) / G model	