

miniBOOSTER HC6DHW



HC6DHW versions: 7 different intensification factors

P_{IN}: Inlet pressure 20-207 bar

P_H: 1,380 bar maximum (outlet pressure)

P_{RETURN}: As low as possible (return pressure to tank)

P_{OUTLET}: $P_H = (P_{IN} - P_{RETURN}) \cdot I$ (intensification)

Mounting: Inline tube

Accessories: Pilot- operated dump valve available

A model = no dump valve

B model = with dump valve

G model = direct proportionally controlled

Material certificate 3.1 on request

Description

The HC6DHW is a high flow dual- acting stainless steel 316 L unit which is capable of delivering up to 12.5 l/min flow on the high- pressure end. Like other miniBOOSTER models, the HC6DHW raises supplied pressure to a higher outlet pressure and automatically compensates for consumption of oil to maintain the high pressure. Adjustment of the outlet pressure is carried out by varying the supplied pressure. Relative to its flow capability, the HC6DHW is a compact unit weighing 35.0 kg.

Flow rates

Intensification factor i	Max. outlet flow l/ min	Max. inlet flow l/ min
4.0	12.5	50.0
4.9	10.0	50.0
6.3	8.0	50.0
8.2	6.0	50.0
11.1	4.5	50.0
13.2	3.5	50.0
16.0	3.0	50.0

Functions

The basic operation is illustrated in the function diagram. Oil is fed through the directional valve CV to the IN port, flowing freely through the check valves 2x KV1, 2x KV2 and DV to the high- pressure side H. In this condition maximum flow through the booster is achieved giving a fast-forward function.

When pump pressure is reached on the high- pressure side H, valves KV1, KV2 and DV will close. The end pressure will be achieved by the oscillating pump units OP1 and OP2 by turns. The unit will automatically stall when end pressure on the high- pressure side H is reached. If a pressure drop on the high- pressure side exists due to consumption or leakage, the OP1 and OP2 units will automatically operate to maintain the end pressure. It is possible to change the high- pressure connection H to the opposite end of the booster.

Function diagram

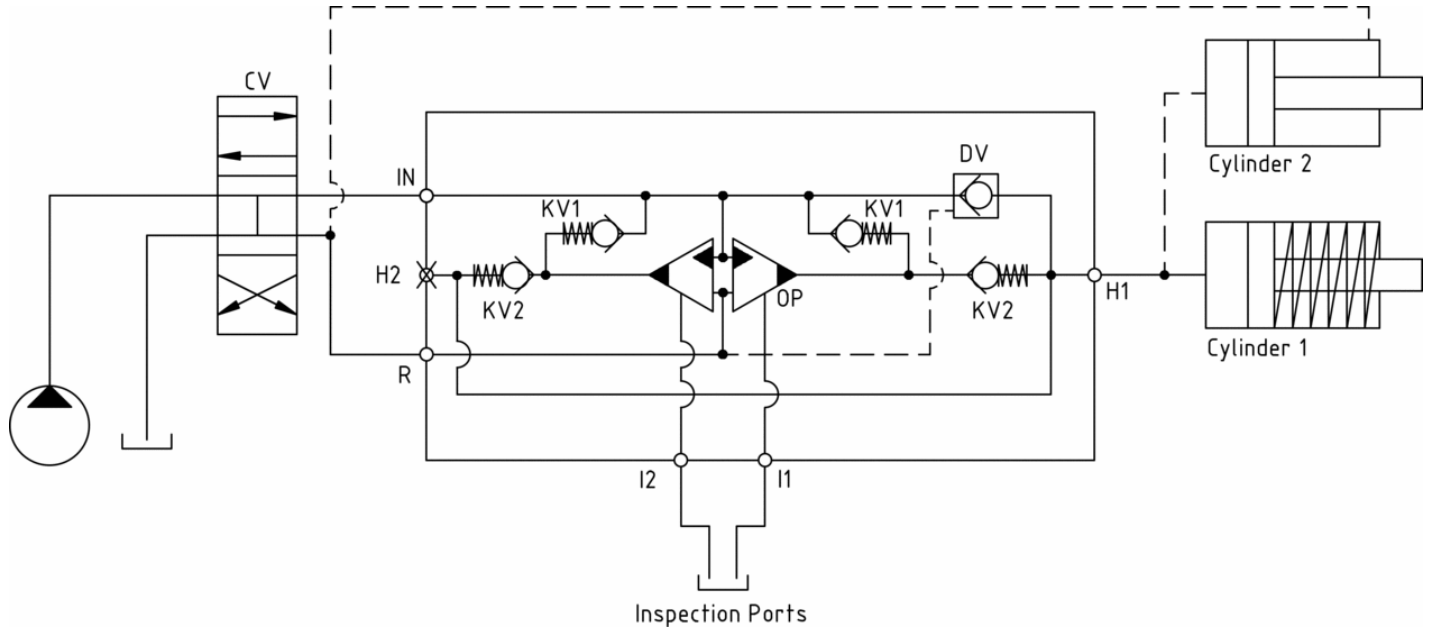

6DW-105-00



Function diagram 6DW-105-00

Dimensions



Dimension drawing 6DHW-124-00

Connection types

Connection	IN / R
1	1/2" BSPP

Max. tightening torque BSPP

IN / R
1/2" BSPP
with stainless steel washer
13.0 da/ Nm

High- pressure adapters

Ordering Code	Male connection 1	Female connection 2	Tightening torque
6DW-816	M30 x 1.5	1/2" BSPP	250 Nm
6DW-817	M30 x 1.5	13/16-16 UNF	250 Nm
6DW-815	M30 x 1.5	Plug	250 Nm

Fluids and materials

Please see: General specifications

Dynamic seals

Code	Seal material	Outlet pressure
HP	H- PUR / PEEK	Max 1,380 bar HP

Ordering an HC6DHW

HC6DHW-: with Bypass Valve (BPV)

Ordering example of an HC6DHW with $i = 4.0$, DV incorporated ,BSPP connections and H- PUR/ PEEK dynamic seals:

HC6DHW - 4.0 - B - 1HP for media $< 5 \text{ cSt (mm}^2/\text{s)}$ tested in water and mounted with H- PUR/ PEEK dynamic seals

HC6DHW - 4.0 - B - 1SHP for media $> 5 \text{ cSt (mm}^2/\text{s)}$ tested in hydraulic oil and mounted with H- PUR/ PEEK dynamic seals

Model	Intensification, i	Dump valve	Connections	Dynamic seals
HC6DHW	- your selection... see flow rate table	- your selection... A = (no) / A model B = (yes) / B model G = (proportional)/G model	- your selection... 1	your selection... HP