

# HC7-9 miniBOOSTER



**HC7-9 versions:** 5 different intensification factors

$P_{IN}$ : 20 – 207 bar (inlet pressure)

$P_H$ : 2000 bar maximum (outlet pressure)

$P_{RETURN}$ : As low as possible (return pressure to tank)

$P_{OUTLET}$ :  $P_H = (P_{IN} - P_{RETURN}) \times i$  (intensification)

**Mounting:** Cartridge

**Accessories:** Pilot- operated dump valve incorporated

**A model** = no dump valve

**B model** = with dump valve

**G model** = direct proportionally controlled

## Description

The HC7-9 is a very compact high- pressure unit capable of delivering pressure up to 2,000 bar weighing only 1.3 kg. It is ideal for use in applications where it is desirable to mount the unit on or in a manifold, cylinder, or other device.

The HC7-9 raises supplied pressure to a higher outlet pressure and automatically compensates for consumption of oil to maintain the high pressure. Adjustment of the outlet pressure is carried out by varying the supplied pressure.

## Flow rates

Intensification factor $i$	Max. outlet flow l/ min	Max. inlet flow l/ min
5.0	1.6	14.0
6.6	1.3	13.0
9.0	0.9	13.0
13.0	0.6	12.0
20.0	0.3	12.0

## Dimensions

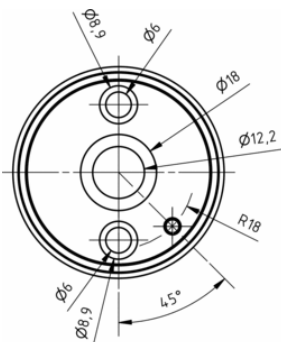

7-136-00

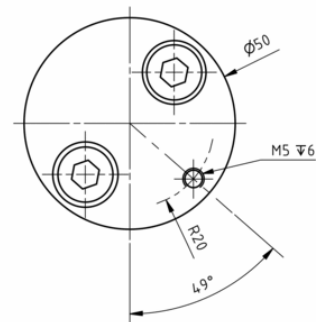
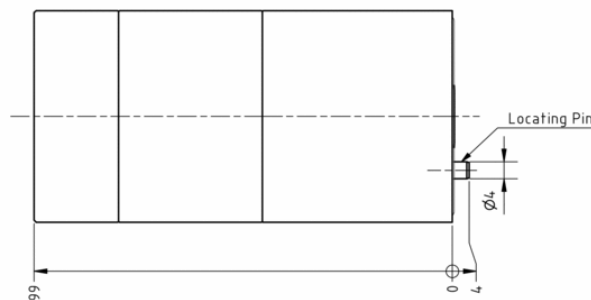

 Download PDF file: 7-905-00\_Mounting instruction

## Functions

The basic operation is illustrated in the function diagram. Oil is fed through the directional valve CV to the IN port, flowing freely through the check valves KV1, KV2 and DV to the high- pressure side H. In this condition maximum flow through the booster is achieved, giving a fast-forward function.

When pump pressure is reached on the high- pressure side H, valves KV1, KV2 and DV will close. The end pressure will be achieved by the oscillating pump unit OP. The unit will automatically stall when end pressure on the high- pressure side H is reached. If a pressure drop on the high- pressure side exists due to consumption or leakage, the OP valve will automatically operate to maintain the end pressure.

## Function diagram

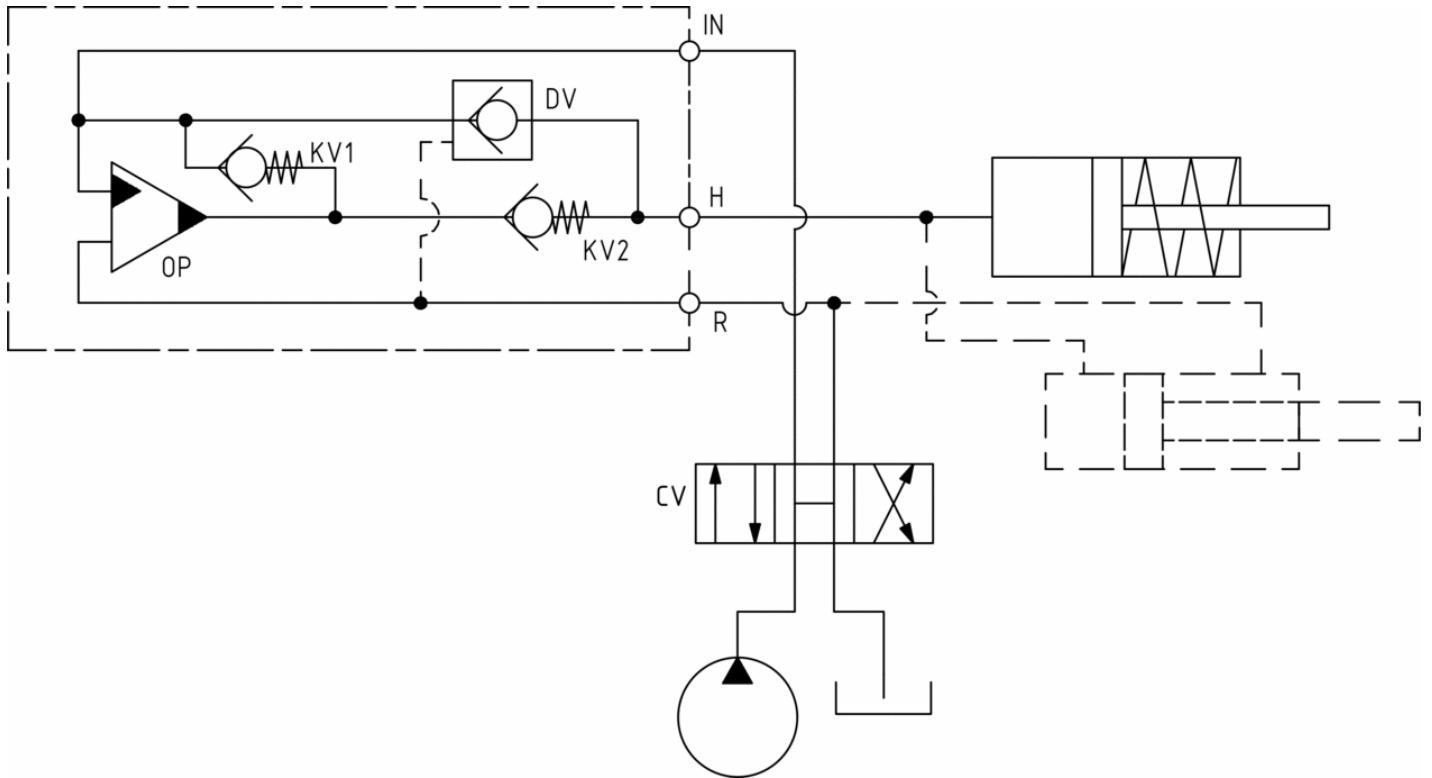

7-107-00

## Fluids and materials

Please see: General specifications

## Ordering an HC7-9

Ordering example of an HC7-9 with  $i = 13.0$  DV incorporated and BSPP connections: HC7 - 13.0 - B - 9

Model	Intensification, $i$	Dump valve	Connections
HC7	your selection... see flow rate table	your selection... A = (no) / A model B = (yes) / B model G = (proportional) / G model	your selection... 9